



LM3605

PRINT & APPLY

OPERATIONS MANUAL



Manufactured in USA by:

LabelMill, Inc.

2416 Jackson St.

Savanna, IL 61074

(800) 273-4707

info@labelmill.com

www.labelmill.com

TABLE OF CONTENTS

SECTION	PAGE
1. APPLICATOR OVERVIEW	
Introduction	1-01
General Printer Specifications	1-02
Inventory List	1-03
Print & Apply Component Description	1-04
User Responsibility	1-05
Safety	1-05
2. SETUP AND OPERATION	
Web Routing	2-01
Thermal Print Head Label Loading	2-03
Thermal Ribbon Loading	2-03
Label Sensor Adjustment	2-03
Take Up Unit Assembly	2-04
Clutch Assembly Adjustment	2-05
Hand Held Labeler Interface HLI-100	2-06
Accessory Connections Control Box	2-07
Communication Connections Control Box	2-08
T-50 Photo Eye	2-09
Air assist tube	2-10
T-150 Mounting Stand (optional)	2-11
T-stand adjustment	2-12
Tamp Unit Operation	2-13
Tamp Flow Control Adjustment	2-14
Optional Adjacent Panel Labeler (APL)	2-15
Optional Corner Wrap	2-16
3. CONTROL BOX	
Programming	3-01
Quick Reference Chart	3-05
Key Definitions	3-15
Set Up Of Key Features	3-16
Description of I/O	3-20
4. CLEANING & MAINTENANCE	
Troubleshooting	4-01
Fault Codes	4-02
Maintaining The Air Slide	4-03
Replacing Main Power Fuse	4-04

SECTION 1

APPLICATOR OVERVIEW

Introduction	1-01
General Specifications	1-02
Inventory List	1-03
Print & Apply Component Description	1-04
User Responsibility	1-05
Safety	1-05

LabelMill LM3605

THERMAL PRINTER/APPLICATOR SYSTEM

INTRODUCTION

The **LabelMill LM3605** is a state of the art THERMAL PRINTER & APPLICATOR SYSTEM created with maximum flexibility for your AUTOMATIC LABELING NEEDS. The unit will print and apply high quality labels and bar codes to your product at print speeds up to 12"/sec. and apply at speeds up to 60 labels/min.

OPERATION

The standard configuration is External Computer Mode. The configuration allows label formats to be sent to the standard USB, Ethernet, Centronics Parallel Interface Port, or Serial Port, on the Printer/Applicator. Once the format is downloaded to the Printer Job Buffer, the LM3605 system can print and apply as normal. Standard industry label software packages can be used in conjunction with a PC to design and load label design.

SPECIFICATIONS

PRINT SPEED	Up to 12"/second and approx. 60 labels/min. (Varies depending on label and product size.)
BAR CODES	Linear and Two-Dimensional Barcodes
BAR CODE RATIOS	1:2, 1:2.5, 1:3 or individually programmable bar code widths
HUMAN READABLE FONTS	OEM Standard Fonts, Firmware Support for Downloadable TrueType Fonts, and Additional Fonts Available
LABEL ROLL CAPACITY	12" Max. outside diameter wound on a 3" diameter core. Die cut waste removed with a minimum of 1/8" separation between labels in running direction.
LABEL SIZE	Minimum: 0.625" wide x 0.50" long Maximum: 6.6" wide x 39" long
MAXIMUM PRINT AREA	6.6" wide x 39" long (Varies dependent upon system configuration)
LABEL PLACEMENT ACCURACY	Up to + or - 1/32" (1mm) when labels are produced to specifications and product handling is controlled.
PRINTING METHOD	Thermal Transfer or Direct Thermal Right-Hand or Left-Hand
INTERFACE	Standard Centronics Parallel Port Standard RS-232C Serial Port, Ethernet port, USB
INTERFACE SENSORS	Ribbon out Product Sensor-Photo Eye-Limit Switch PLC input
ELECTRICAL	115V AC/60 Hz-250 W idle, 600 W running.
AIR REQUIREMENT	80 p.s.i./3 cfm
SIZE	23" T x 30" W x 23-3/8" D
ENVIRONMENT	Operating Temp. 50-95 F (10-35 C) 15-85% RH. non-condensing
WEIGHT	60 lb. (with U-Arms)

*Options available

INVENTORY LIST

QTY.	Description
1	Print & Apply Assembly
2	12-1/2" dia. Blue Plastic Spools w / Quick Release Collar
1	7-3/4" dia. Blue Plastic Spool w / screws
2	1/2" - 13 bolts w / washers
1	Power Cord
1	Model LM3605 Operators Manual
1	Extra Cardboard Ribbon Core
1	Product Switch (specified)
	a. Manual Limit Switch (optional)
	b. Photo Switch (optional)
1	Take-up Spool Clip

TOOLS REQUIRED FOR ASSEMBLY

:
3/32" ALLEN WRENCH
3/4" WRENCH
1-1/8" WRENCH

COMPONENT DESCRIPTION / LOCATION

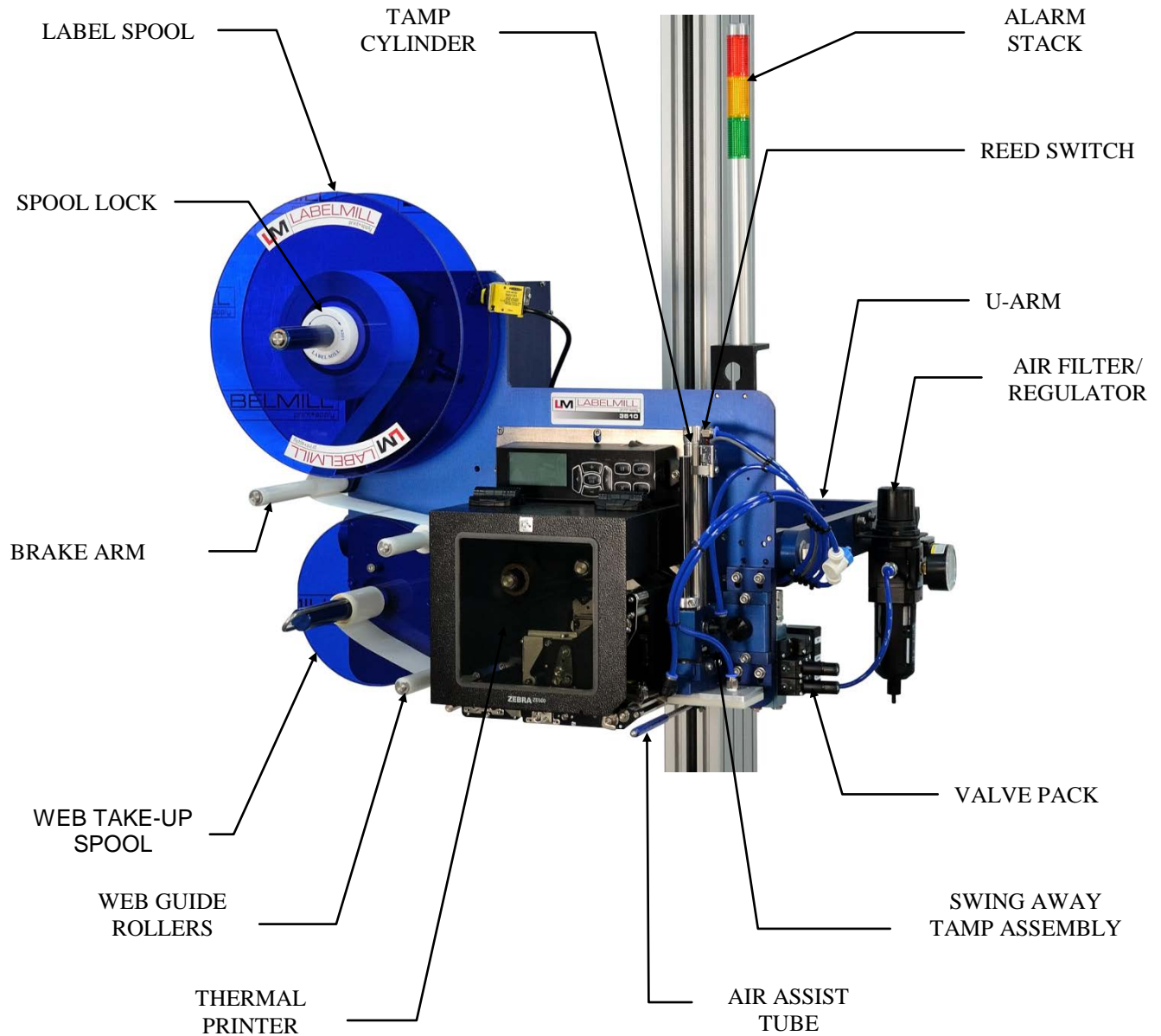

USER RESPONSIBILITY

This equipment will perform in conformity with the description thereof contained in this manual and accompanying labels and / or inserts when installed, operated, maintained, and repaired in accordance with the instructions provided. This equipment must be checked periodically. Defective equipment should not be used. Parts that are broken, missing, plainly worn, distorted, or contaminated should be replaced immediately. Should such repair or replacement become necessary, we recommend that a request for service advice be made.

This equipment or any of its parts should not be altered without the prior written approval of MM2, Inc. The user of this equipment shall have the sole responsibility for any malfunctions which results from improper use, faulty maintenance, damage, improper repair or alteration by anyone other than MM2, Inc. or a service facility designated by MM2, Inc.

SAFETY

Only qualified personnel should use this equipment.

Before installing, inspecting or servicing equipment, turn OFF all power and air controls at the source and lock out in accordance with OSHA Standards.

Be sure all external electrically conductive parts are connected to a good electrical ground.

Never handle live electrical equipment with bare hands while standing in water, or while hands and feet are wet. Dangerous electrical shock can result.

Whenever the equipment is unattended, turn off all control and power supply switches.

Keep equipment clean and in good operating condition. Promptly repair or replace all worn or damaged hoses, cables or parts.

Do not make any repairs to equipment unless you are fully qualified.

This equipment contains fast moving parts, which may move without warning. Keep hands, loose hair and clothes clear of machines at all times.

Never place hands or any other body parts under the label platen at any time.

This equipment uses compressed air. Proper care and maintenance must be taken when handling compressed air and its components.

These precautions are further detailed and explained where specifically required in this manual.



READ AND UNDERSTAND THESE INSTRUCTIONS

Protect yourself and others. Be sure this information is read and understood by all operators.

ELECTRICAL SHOCK CAN KILL!

Do not touch live electrical parts with bare skin or work with gloves or wet clothing.

NOISE CAN DAMAGE HEARING!

Wear proper ear protection.

SECTION 2

SETUP AND OPERATION

Web Routing	2-01
Thermal Print Head Label Loading	2-03
Thermal Ribbon Loading	2-03
Label Sensor Adjustment	2-03
Take-Up Unit Assembly	2-04
Clutch Assembly Adjustment	2-05
HLI-100 Hand Held Interface	2-06
Accessory Connector Panel	2-07
T-55 Photo Eye	2-09
Air Assist Tube	2-10
T-150 Mounting Stand (optional)	2-11
T-stand Adjustment	2-12
Tamp Unit Operation	2-13
Tamp Flow Control Adjustment	2-14
Optional Tamp Applicator	2-15
Optional Corner-Wrap Applicator	2-16
Optional Adjacent Panel Labeler (APL)	2-17
Optional Table-Top Configuration	2-18

WEB ROUTING

Step	Operation
1	Load web onto label storage spool (A) so it unloads in a clockwise direction.
2	Feed the web to the left and below roller guide (B), to the right of roller (C) and to the left and below roller guide (D).
3	Feed the web into the thermal printer.
4	Finish the process by loading the waste backing paper onto the web take up spool (E). The take up spool rotates in a clockwise direction.
5	Adjust the (2) plastic web guide clips so the web is guided straight and even. Make sure clips do not bind the web.

*For a detailed illustration of this procedure, see Figure 2-1 below.

FIGURE 2-

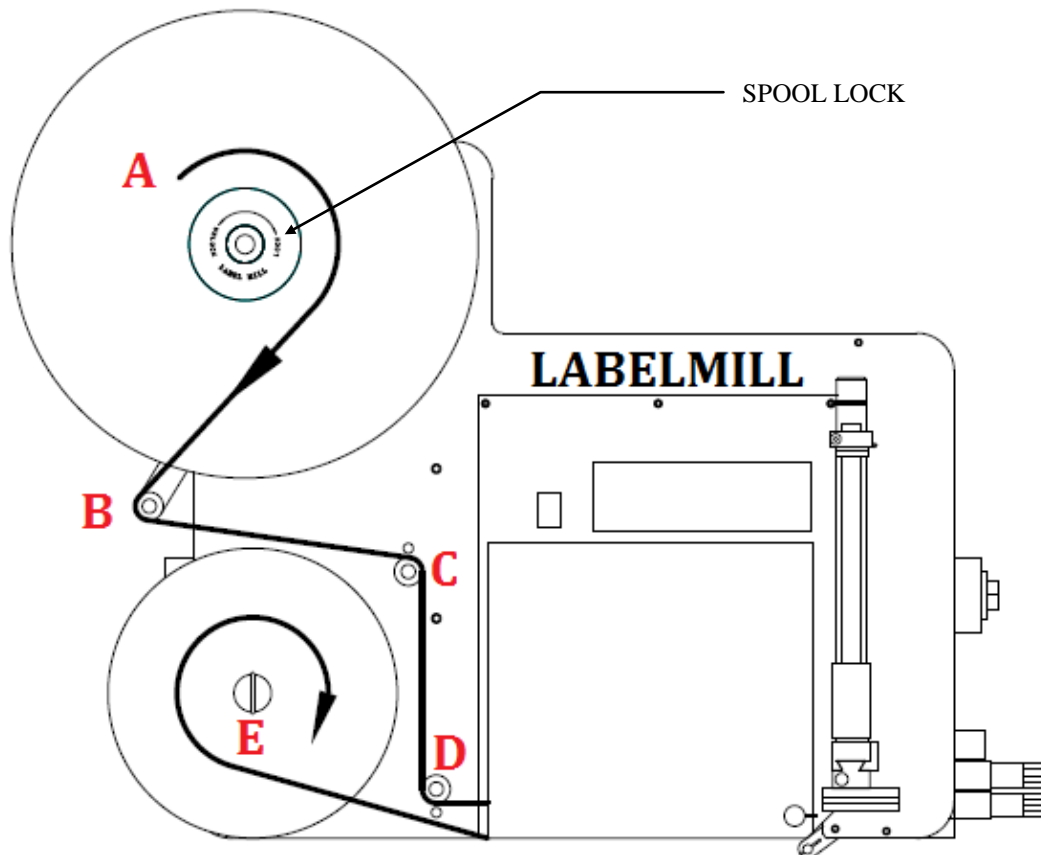

2-01

WEB ROUTING

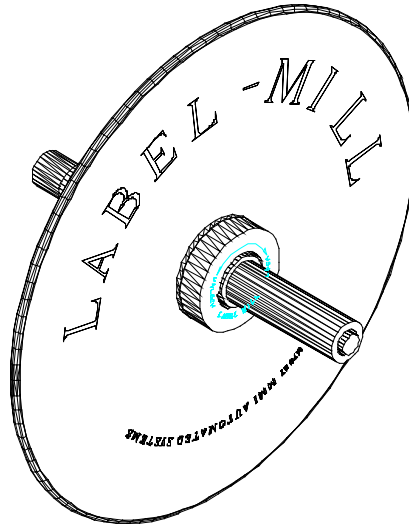

SPOOL LOCK REMOVAL: To remove the label storage spool (A), turn the spool lock counterclockwise until you reach a stop. The spool will now slide off. To secure the spool, simply turn the spool lock clockwise until snug. **DO NOT** over tighten!

LOADING THERMAL PRINT HEAD

REFER TO PRINTER MANUAL

LABEL & RIBBON ROUTING

REFER TO PRINTER MANUAL

THERMAL RIBBON LOADING

REFER TO PRINTER MANUAL

NOTE: The printer will not operate unless the front cover is in the fully closed position. For your continued safety, do not override the front cover interlock switch.

LABEL SENSOR ADJUSTMENT

REFER TO PRINTER MANUAL

TAKE-UP UNIT ASSEMBLY

- (A)...TAKE-UP SPOOL
- (B)...BEARING BODY
- (C)...GEAR MOTOR
- (D)...CLUTCH ASSEMBLY

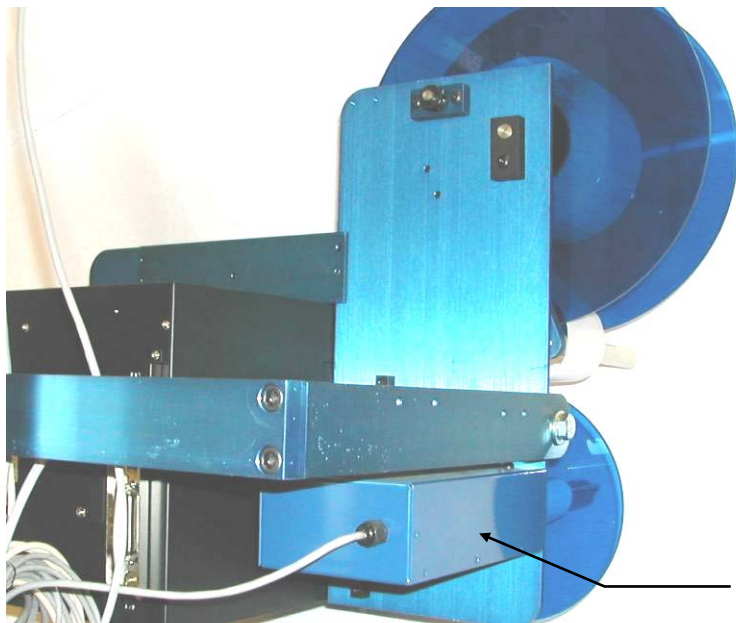
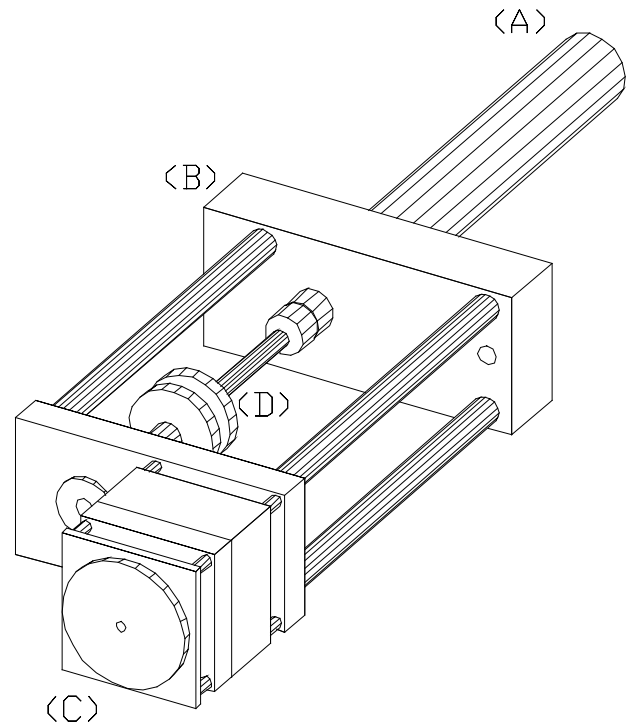

TAKE-UP
ASSEMBLY

The Take-Up Assembly is located on the backside of the main panel. To adjust the clutch, the side panels must be removed to gain access. To remove the Clutch Assembly, you must first remove the Web Take-Up Spool. The mounting bolts for the Take-Up Assembly can be found directly behind the plastic spool.
WARNING!!! Be sure power is off before performing any service.

CLUTCH ADJUSTMENT

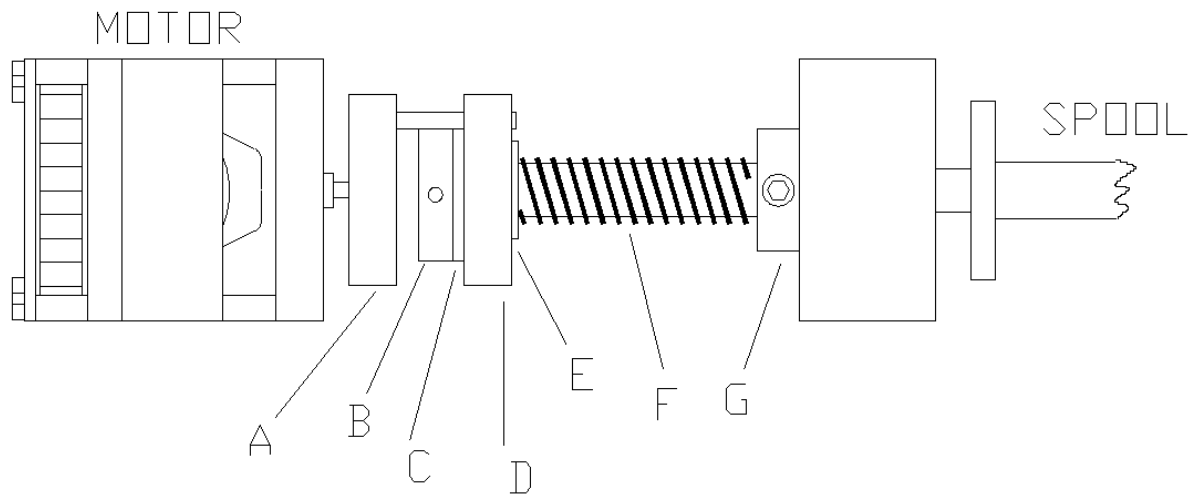

- (A) DRIVE DOG
- (B) SHAFT WHEEL
- (C) FRICTION DISC
- (D) PRESSURE PLATE
- (E) THRUST BEARING
- (F) PRESSURE SPRING
- (G) TENSION ADJ. COLLAR

To increase waste web tension, move the shaft wheel (B) 1/32" toward the Spool. To reduce web tension, move the shaft wheel (B) 1/32" toward the motor.

CAUTION... Too much web tension may cause web breakage, print drifting, or premature failure of the Take-Up Assembly.

HAND HELD LABELER INTERFACE HLI-100

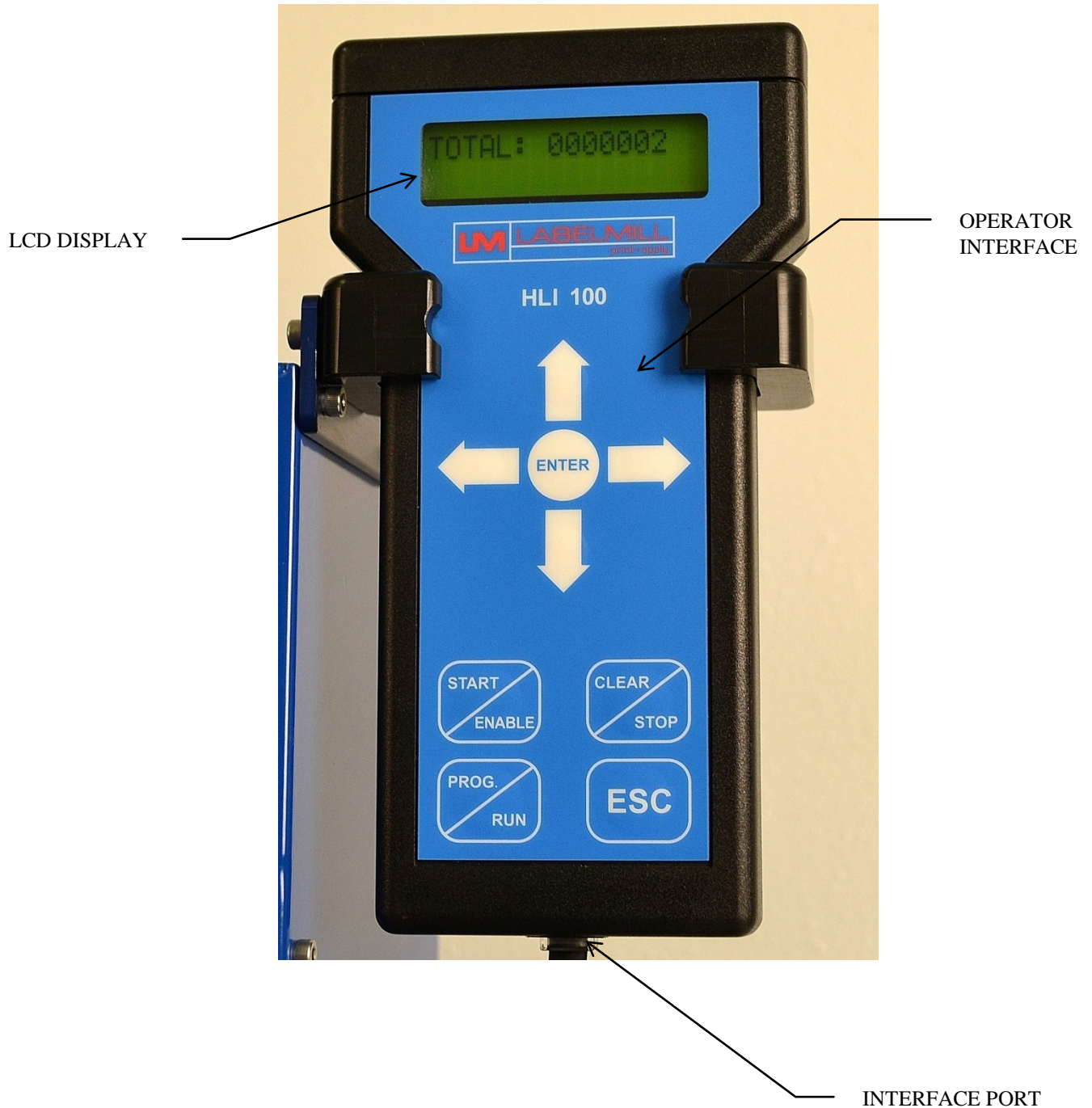

ACCESSORY CONNECTIONS

LOCATED ON BACK OF LABELER CONTROL ENCLOSURE

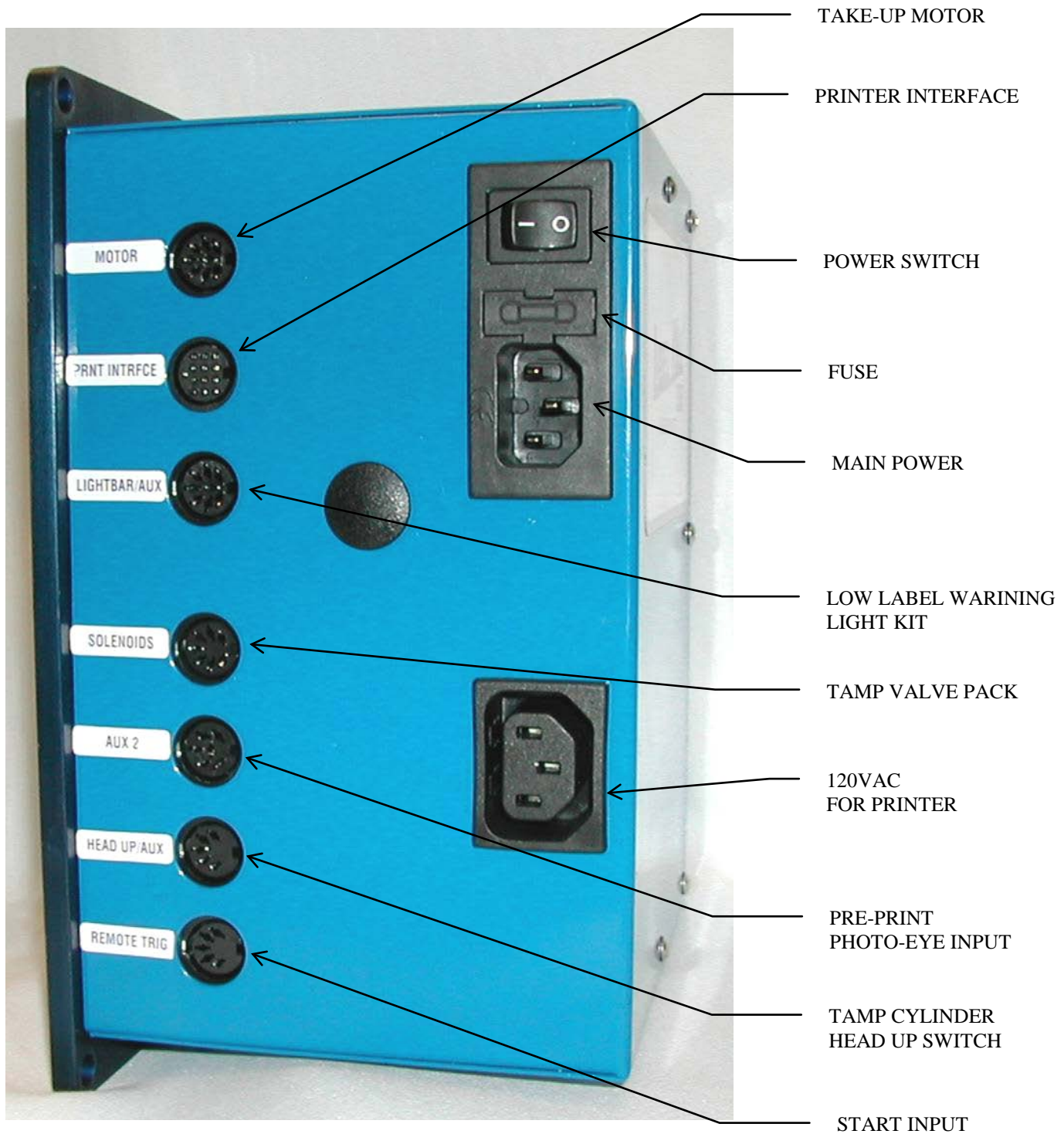

COMMUNICATION CONNECTIONS



T-55 PHOTO EYE

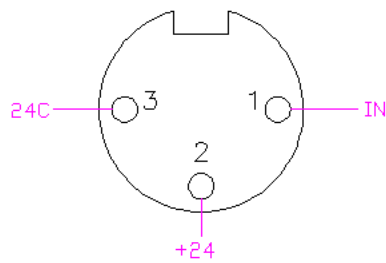

AIR ASSIST TUBE

The Air Assist Tube must be adjusted to clear the trailing edge of the printed labels and the Label Platen. An adjustment screw is used to adjust the position of the air holes in relation to the labels. An angle of 45 degrees is required.

One slot is provided to make the appropriate adjustments desired.

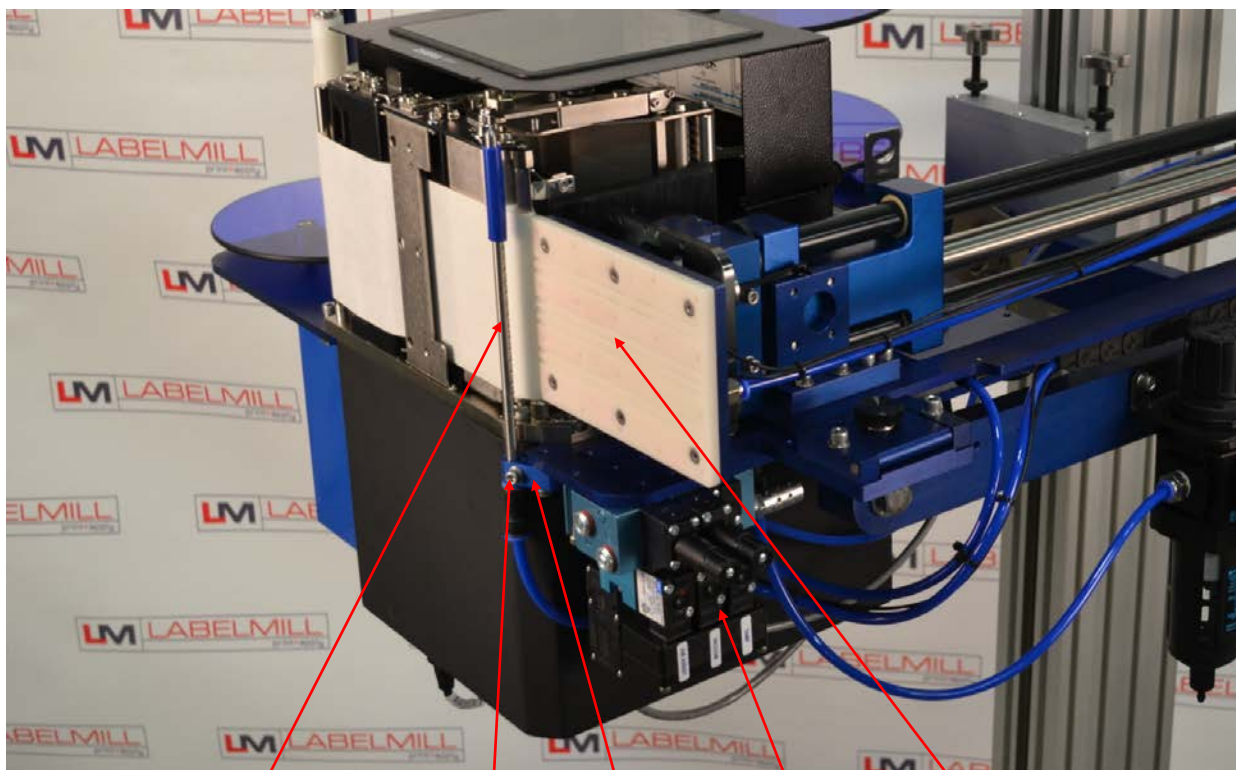
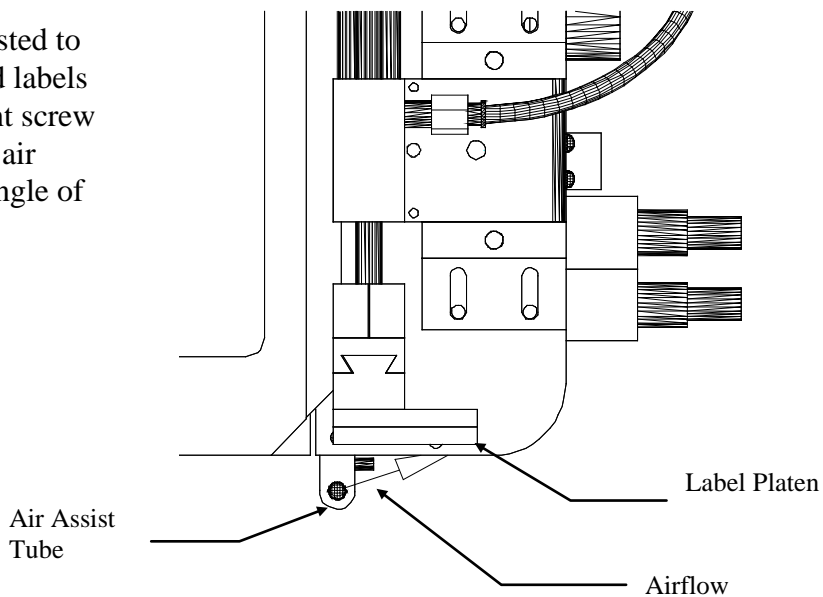

Air Assist Tube

Clamp screw

Mount Bracket

Valve Pack

Label Platen

2-10

OPTIONAL T-150 MOUNTING STAND



T-STAND ADJUSTMENT



TAMP UNIT OPERATION

- TAMP Duration

Tamp duration is used to provide an on timer for the solenoid valve on the main tamp cylinder. The delay on standard versions can be from 0 to 30.000 seconds in 1/1000 of a second accuracy. This allows for easy change over from one product height to another without physically changing the height of the unit. It also allows for precise adjustments of how close the tamp head comes to the product. (refer to page 3-08)

There is flow control adjustment for the valves. It may be necessary to adjust the flow rate on the tamp solenoid for optimum performance after installation. The adjustment is performed as shown below. They are set at the factory. The regulators on the vacuum, air assist, and flag valves are for increasing or decreasing the air pressure as necessary for proper operation. Note: Flag Regulator not shown below – only supplied with flag applicators.

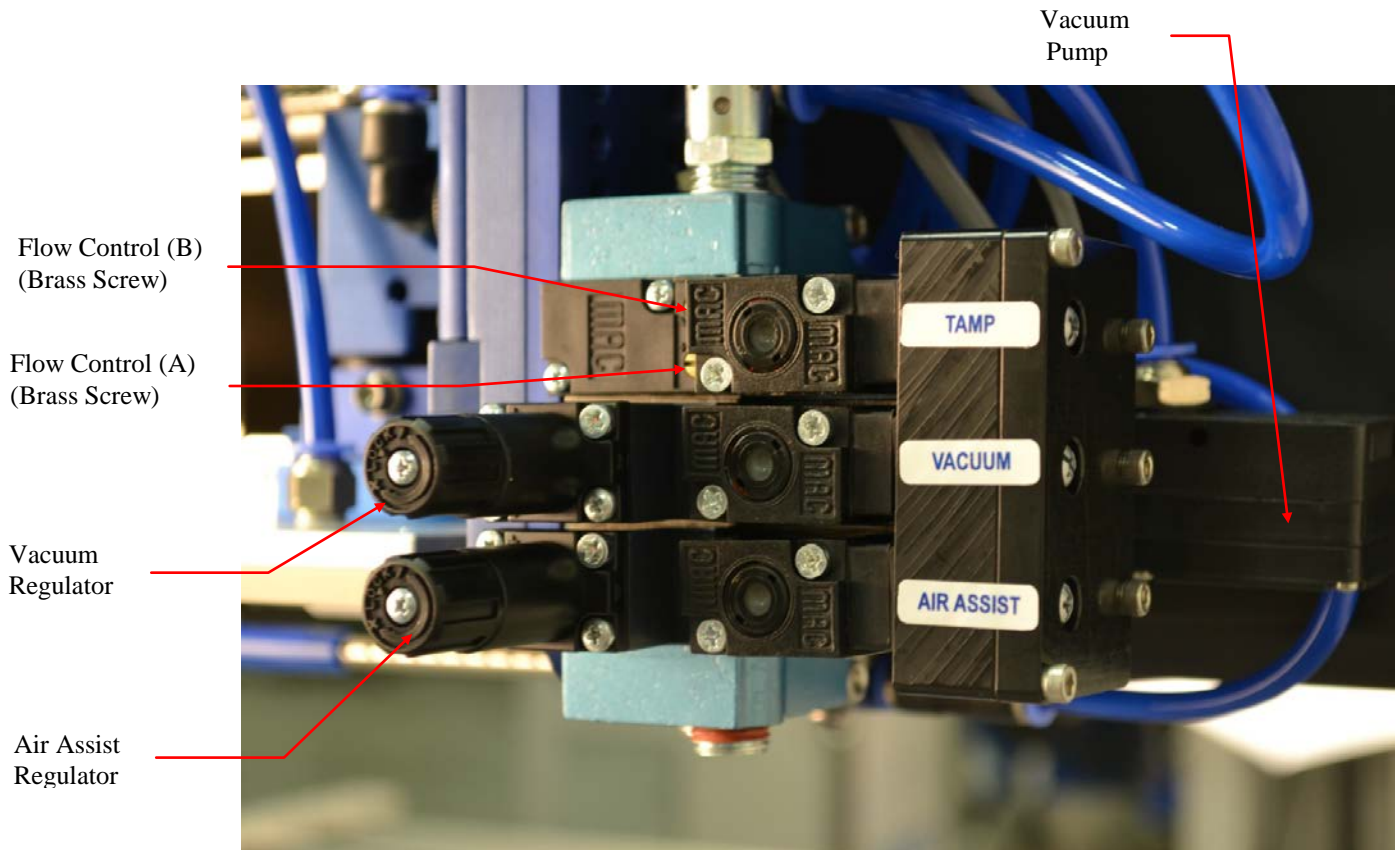

TAMP FLOW CONTROL ADJUSTMENT

Regulator Adjustment: **Clockwise** - Increase pressure **Counterclockwise** - Decrease pressure

MAIN AIR REGULATOR

Controls maximum air pressure available to entire applicator. Should be set between 40 and 80 PSI.

FLAG REGULATOR

The flag regulator is used to adjust the pressure that the flag jaws apply to the label as it is applied.

VACUUM REGULATOR (only used on the flag and tamp applicator system)

The vacuum regulator is used to control the vacuum that is used to hold the label to the flag jaws or the tamp pad.

AIR ASSIST REGULATOR

The air assist regulator is used to change the pressure that is applied to the blow tube. The blow tube is below the front edge of the peeler plate and is used to help "push" the label onto the bottom of the tamp pad or the flag jaws.

FLOW CONTROLS (tamp and flag applications)

Control A: This is used to adjust the pressure that controls the tamp cylinder in the upward direction.

Control B: Controls the tamp cylinder in the downward direction.

OPTIONAL TAMP APPLICATOR



OPTIONAL CORNER-WRAP APPLICATOR



OPTIONAL ADJACENT PANEL APPLICATOR



OPTIONAL TABLE-TOP APPLICATOR

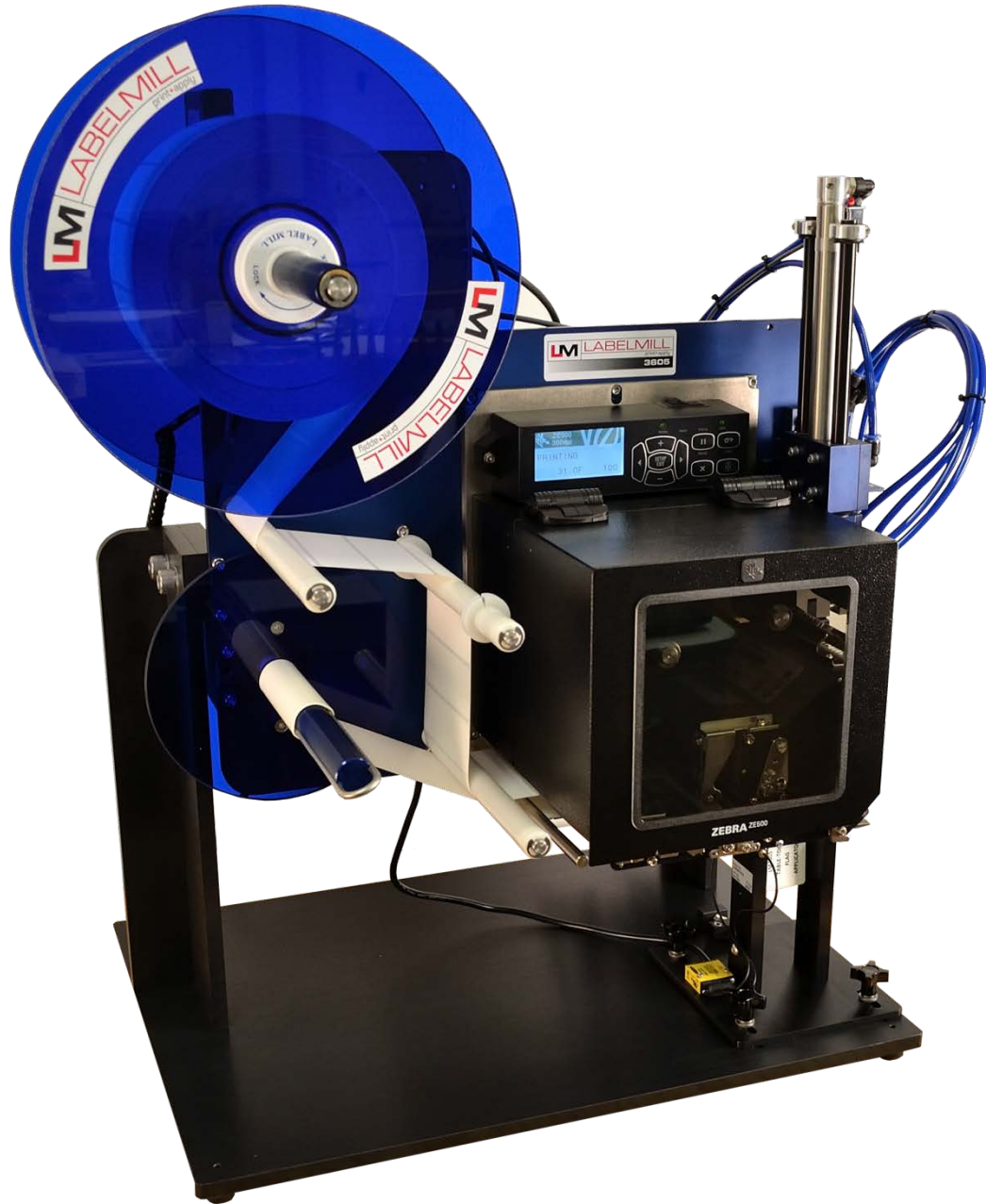

SECTION 3

CONTROL BOX

Programming	3-01
Quick Reference Chart	3-04
Key Definitions	3-13
Set Up of Key Features & Quick Start	3-14
Description of I/O	3-17

PROGRAMMING

All programming is performed via the **HLI-100** keypad and display as shown on page 2-6. All programmed settings are backed in nonvolatile memory and are not lost when the unit is powered off.

Upon power up of the control, the screen will display *MODEL NUMBER & REVISION* of the HLI-100 and then the *MODEL NUMBER & REVISION* of the labeler control. After this, the screen will now display the counter, *TOTAL XXXXXXXX*.

- **KEY FUNCTIONS:**

“**PROG**” PROGRAM KEY IS USED TO:

1. **Enter and exit** the program menu.

“**ENTER**” KEY IS USED TO:

1. Access or “Enter” the selected “PROGRAM BLOCK”. (example PRODUCT SENSOR or TAMP SETUP)
2. Access or “Enter” the **data selection/options** line (bottom line of display) of the “PROGRAM BLOCK” **Sub Menus**.
3. Store the selected data.

UP / DOWN ARROW KEYS ARE USED TO:

1. Scroll up & down through the primary menu “PROGRAM BLOCKS” . (Header name)
2. Scroll **sub menus** inside of “PROGRAM BLOCKS”. (top line of display while **IN** a “PROGRAM BLOCKS”)
3. Increment and decrement programmable values.
4. Select different display views while in the “RUN” mode.

Left / Right ARROW KEYS ARE USED TO:

1. Move the “up carrot” left or right when programming a value.

START / ENABLE KEY:

1. Start key will initialize the application cycle.
2. Enable key will “Enable” the drive after it has been disabled.

CLEAR / STOP KEY:

1. Stop key will abort the cycle only when not in the program menu.
2. Clear key will delete stored values while in the edit mode.
3. Clear key will disable the drive.

ESC (escape) KEY:

1. Will back out of the sub programming menu without saving changes.

• PASSWORD

The PASSWORD is used to lock the menus of the control. This option is used to prevent unauthorized access to variable data. When shipped from the factory, the pass word is to 7074 and NO MENUS are locked. The password cannot be changed.

• PRODUCT SENSOR

This is an external device that when “activated” starts the application cycle.

PROGRAMMABLE BLOCKS:

Product Delay – delays the application of the label (x) seconds after the sensor has been activated.

Sensor Trigger – designates whether the product sensor is activated at the leading or trailing edge of the product.

On Debounce – allows a small delay to be programmed in to prevent false triggering on the **leading** edge of the product.

Off Debounce - allows a small delay to be programmed in to prevent false triggering on the **trailing** edge of the product.

Multiple Feed – how many labels are applied to one product with one signal.

Interval Delay – amount of time in seconds between multiple fed labels Note: only active if quantity 2 or higher

• TAMP SET UP

This is used to adjust the different variables related to the tamp cycle.

PROGRAMMABLE BLOCKS:

Tamp duration – used to adjust the time that the tamp cylinder valve is actuated. (0.000 to 9.999)

Flag duration – used to adjust the time the flag jaws are held open after label application. (00.00 to 99.99)

Head up limit switch – type: **normally open**-standard, normally closed, none

Head up Debounce – Debounce is used to allow time for the tamp cylinder to settle on return. (00.00 to 01.00)

Vacuum Release – Used to release label when tamping on light products.

Vacuum Delay On – Used to reduce label flutter when feeding large labels while tamping.

• TAKE UP

This is used to delay the start and stop of the take up motor.

PROGRAMMABLE BLOCKS:

Start delay – delays (x) seconds after start print before starting take up motor.

Stop delay – take up runs (x) seconds after end print signal is received from printer.

Jog take up – press the UP ARROW to start and the DOWN ARROW to stop the take up motor.

• COUNTER

Used to reset the internal counter of the control.

• PRINT TYPE

The print type command is used to activate the print repeat cycle in the supplied print engine. This feature will continue to print the **last label** in the buffer after the buffer count has expired.

PROGRAMMABLE BLOCKS:

Reprint – Turns reprint option ON or OFF

Serial End – On or Off / sends a serial command out comm. #1 serial port(ESC / D / CR) at the “End of Cycle”.

Char-1	ESC	27 decimal
Char-2	D	68 decimal
Char-3	CR	13 decimal

• CYCLE TYPE

Cycle Type determines the application type and sequence in relation to the label feed.

PROGRAMMABLE BLOCKS:

Tamp Before Feed – (standard) Tamps label first, prints label second

Tamp After Feed – Prints label first, tamps label second

Blow Before Feed – Blows on label first, prints label second

Blow After Feed - Prints label first, Blows on label second

Pre-Print Tamp – *see below*

Pre-Print Blow – *see below*

Clamshell Before Feed – Clamshell applies label first, prints label second

Clamshell After Feed – Prints label first, clamshell applies label second

• JOB STORAGE

Used to store frequently used settings pertaining to different labeling jobs.

PROGRAMMABLE BLOCKS:

SAVE JOB – stores settings for active job.

RESTORE JOB – Restores saved job.

• DEFAULT SETTINGS

This setting will return the controller to the default settings.

• I/O STATUS

Displays the status of the inputs and outputs

QUICK PROGRAMMING CHART

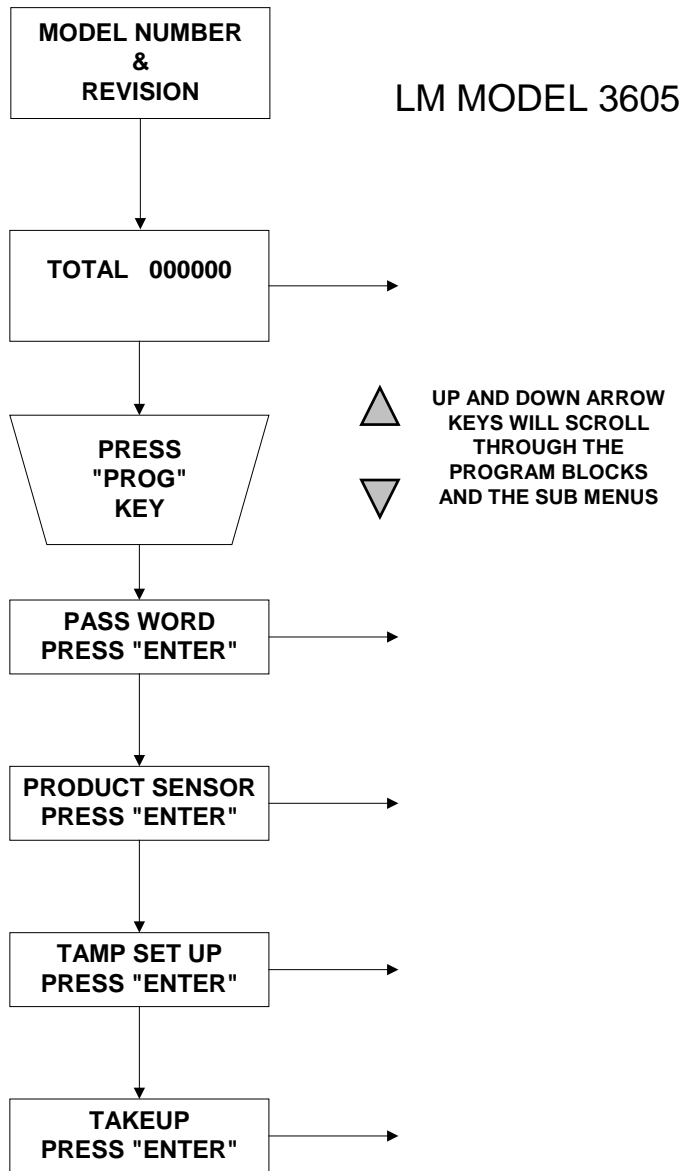

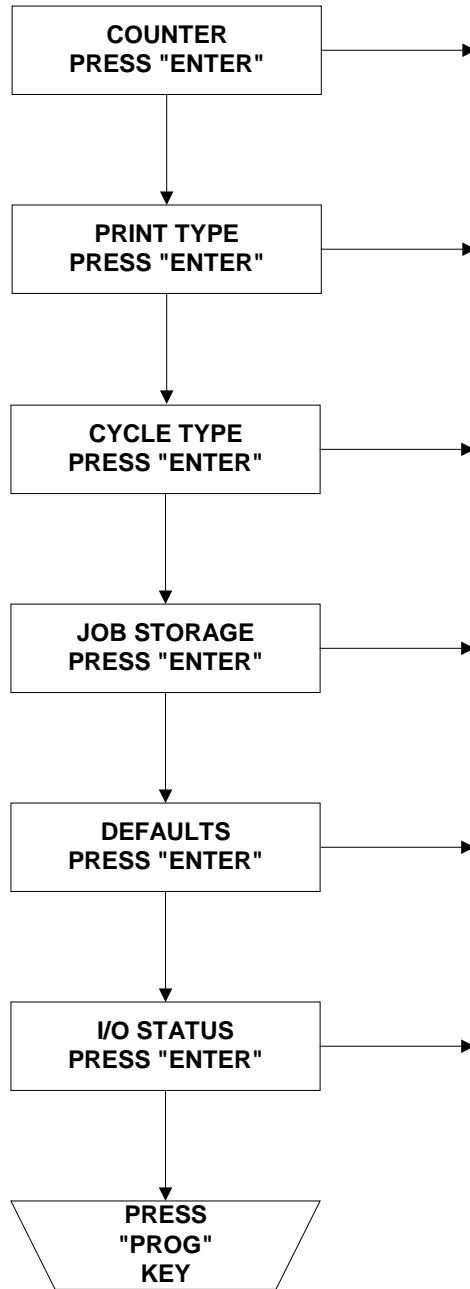

MAIN DISPLAYS

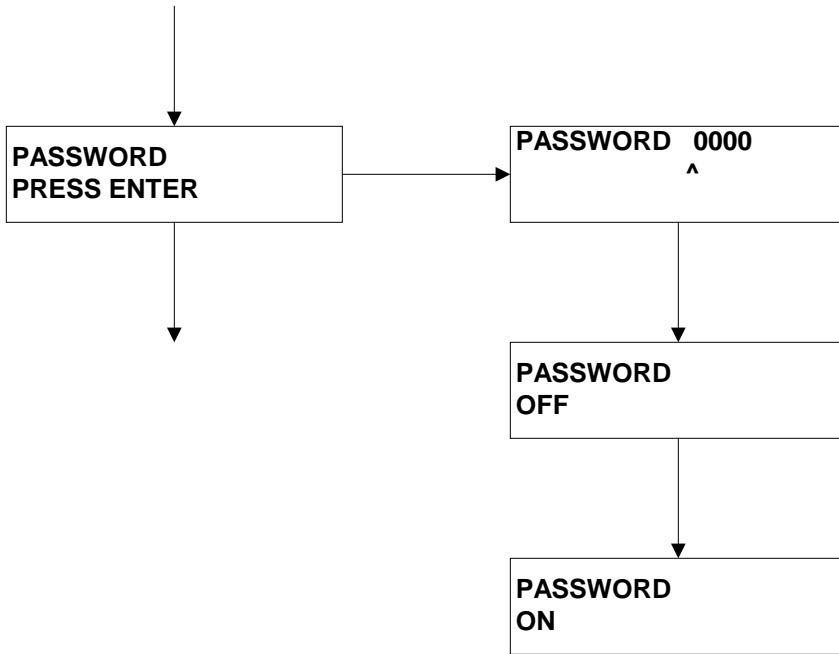

Note: use UP and DOWN arrows to toggle between "ON" and "OFF". The enter key will save selection.

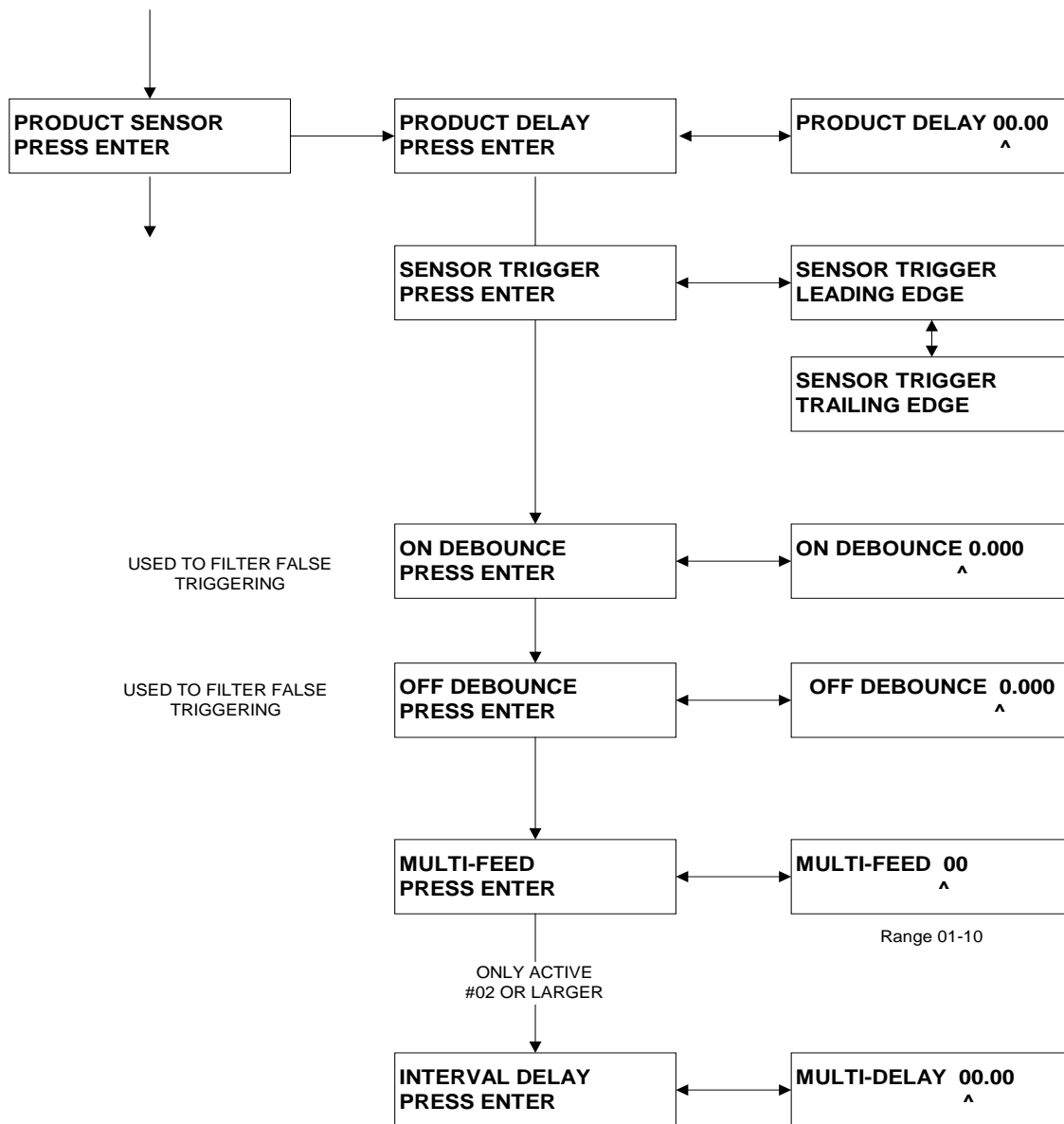

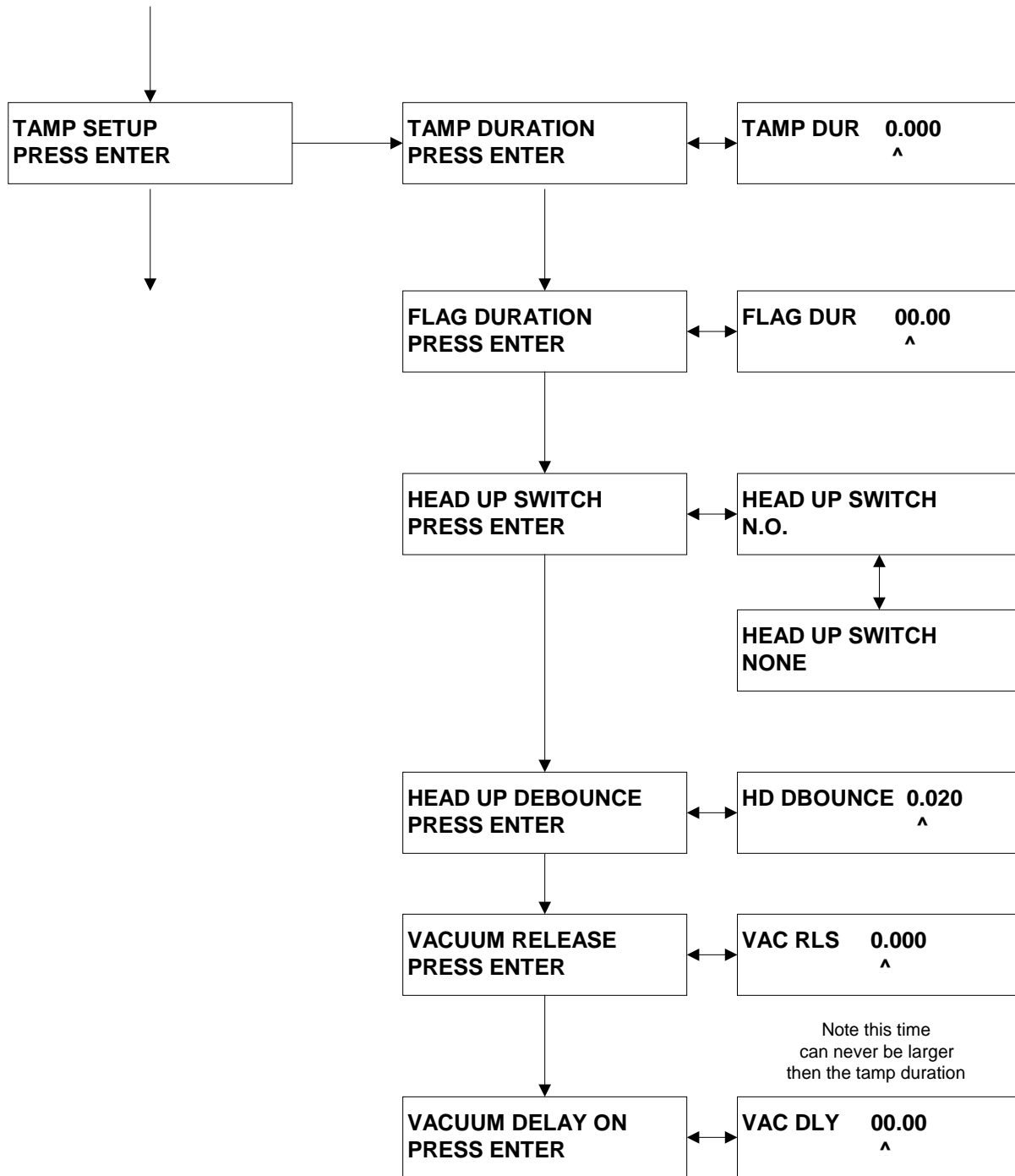

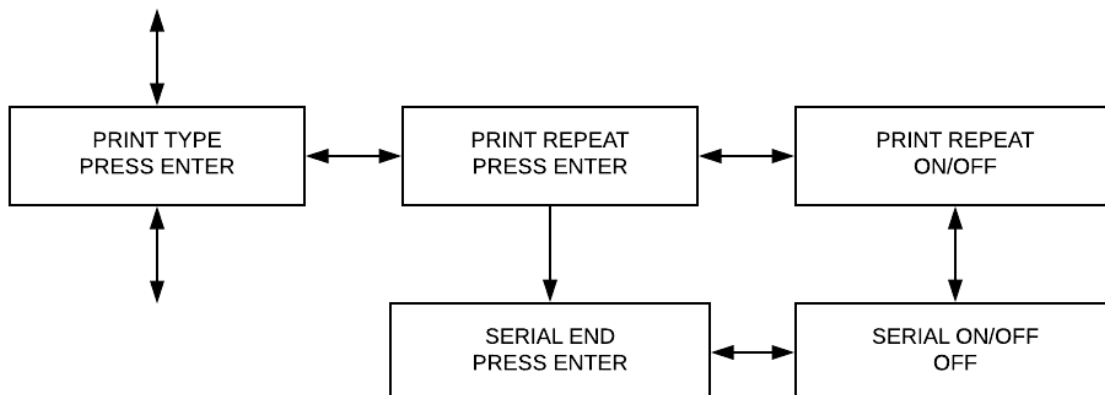
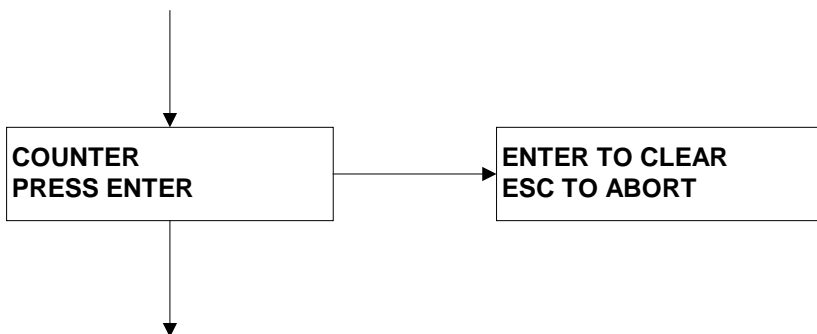
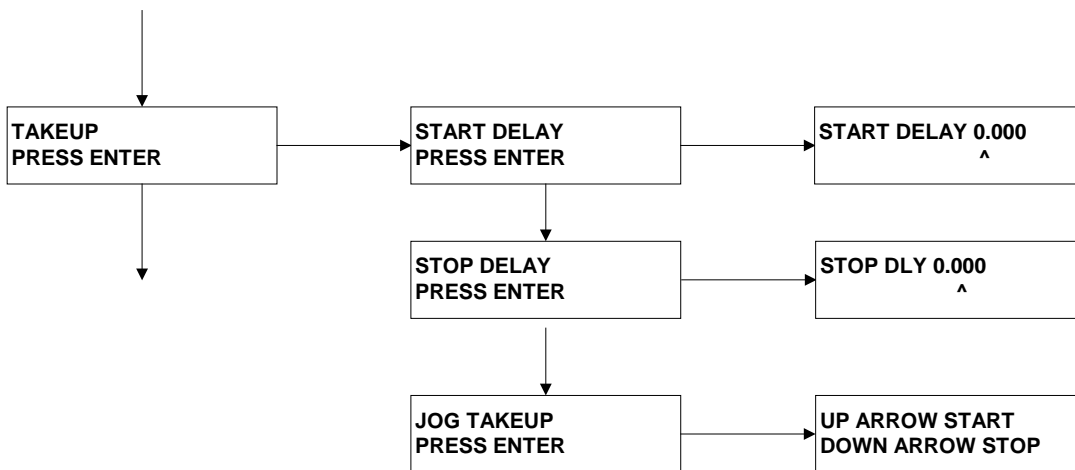

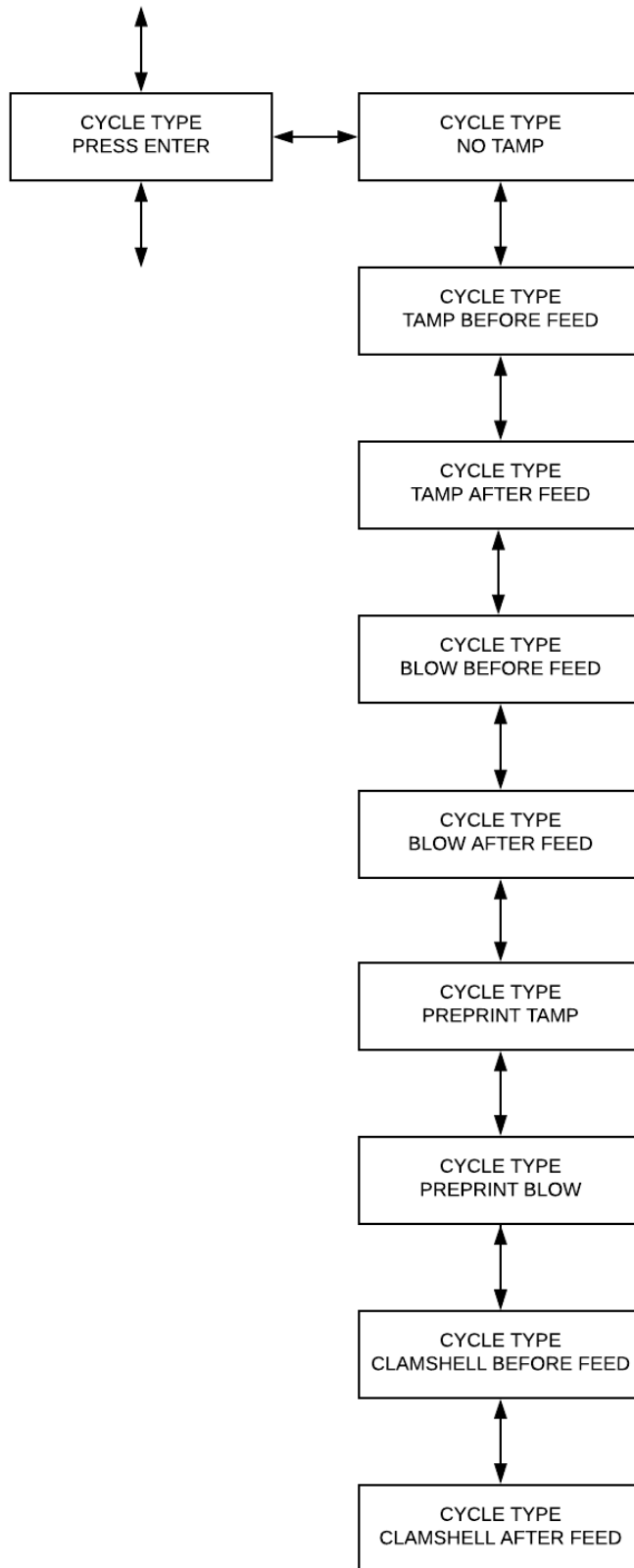

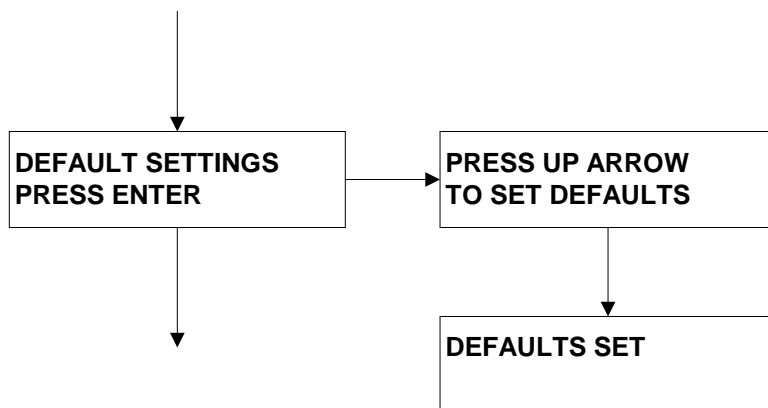
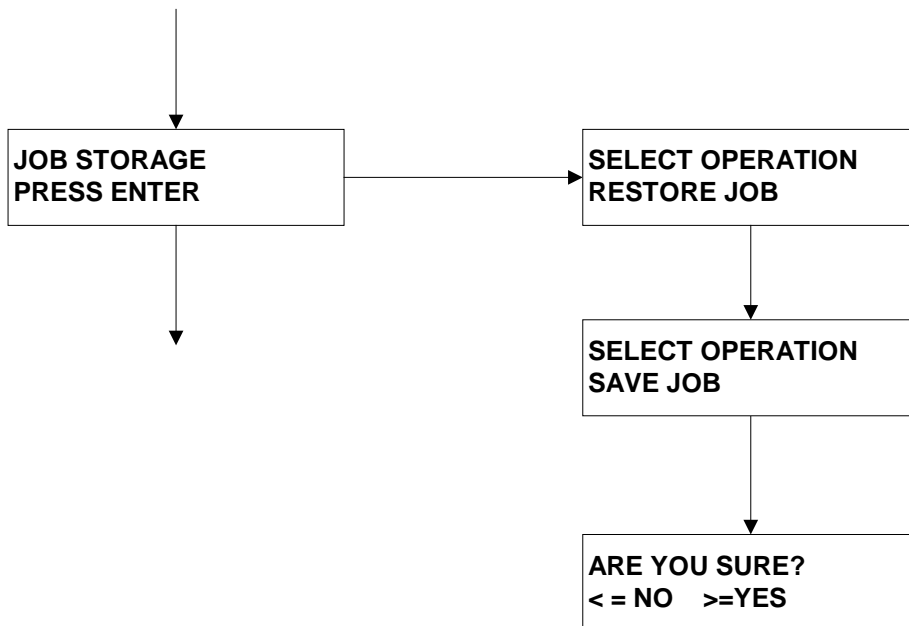

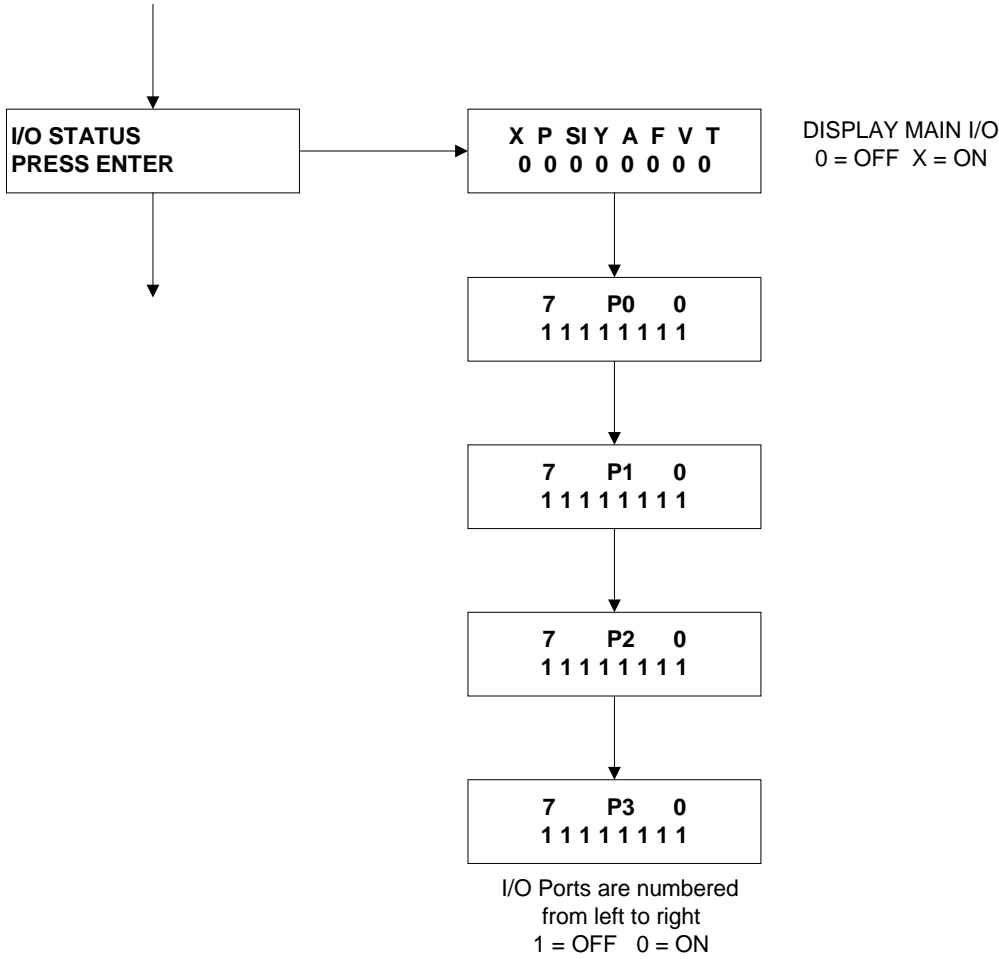

KEY DEFINITIONS

- **ASYNCHRONOUS OPERATION** – The term “ASYNCHRONOUS OPERATION” is used because the speed of the printer applicator motor (label speed) does not necessarily match the speed of the product conveyor. In other words their speed is set independently of one another and has NO interrelation. The 3605 can only be configured in asynchronous operation.
- **SYNCHRONOUS OPERATION** - **The LM3605 can NOT be configured in synchronous operation.** The term “SYNCHRONOUS OPERATION” is used because the speed of the applicator motor (label speed) is matched to the speed of the product conveyor
- **PRODUCT DELAY** is used to electronically move the placement of the label on the product. Product delay will move the label placement in time (00.000) seconds. Because the product delay feature utilizes time, the speed of the product **MUST** remain constant. A product traveling at a higher velocity will travel further in a given time, thus effecting the placement of the label.

QUICK START GENERAL SETUP

1. Inspect applicator system and verify all cables are installed properly.
2. Web system with labels.
3. Turn power switch on.
4. Press "PROG"
5. Press down arrow
6. Enter Defaults
7. Press Up Arrow
8. Defaults are now set
9. Down arrow to Tamp Setup
10. Set tamp duration to .500 and set Head up switch to "N.O."
11. Arrow down to Cycle Type
12. Set cycle type to "Tamp before feed"
13. System is now ready for set up of advanced features and options.

SETUP OF KEY FEATURES

HOW TO SET UP AN ASYNCHRONOUS APPLICATION

- **"TAMP"**

Determine the following and select it in the software

1. Type of application mode. MENU "CYCLE TYPE"
2. Tamp before or after feed (before feed is standard)
3. Enter a value in the tamp duration (start with 00.500) MENU TAMP SETUP
4. Set head up limit switch, normally open is standard MENU TAMP SET UP
5. Use the product delay to "MOVE" the label on the product

The asynchronous application mode is used to apply labels to products that are either stationary or moving at a constant speed when the label application is to take place.

- **"BLOW"**

Determine the following and select it in the software

1. Type of application mode. MENU "CYCLE TYPE"
2. BLOW before or after feed (before feed is standard)
3. Enter a value in the tamp duration (start with 00.10) MENU TAMP SETUP
4. Set head up limit switch, NONE is standard MENU TAMP SET UP
5. Use the product delay to "MOVE" the label on the product

The asynchronous application mode is used to apply labels to products that are either stationary or moving at a constant speed when the label application is to take place.

- **PRODUCT DELAY**

PRODUCT DELAY is NOT used in conjunction with the encoder feature. Product delay is similar to trigger distance in that it is used to electronically move the placement of the label on the product. Product delay will move the label placement in time (00.000). Because the product delay feature utilizes time, the speed of the product MUST be constant and consistent.

1. Set basic applicator up first, refer to quick setup
2. Ensure that applicator is operating properly before starting this procedure.
3. This feature requires the use of an encoder. The appropriate encoder features should be setup prior to this feature.
4. Set Product delay to 00.000
5. Start system and apply label at the desired speed.
6. Check the placement of the label on the product.
7. Measure the OFFSET of the label placement. Note: A label CAN NOT be advanced on the product ONLY moved "back" since the applicator can only delay the product signal.
8. Apply a small delay to the product delay or if too great, it may be necessary to physically move the product switch. Keep product delays to a minimum for best results.
9. Operate system again and measure offset.
10. Apply a small delay to the product delay or reduce if too much.
11. Test again, repeat if necessary until label is in proper registration.
12. Turn back on any options that may have been disabled for setup of this particular feature

HOW TO APPLY MULTIPLE LABELS TO A SINGLE PRODUCT

Product delay is used to electronically move the placement of the **FIRST** label on the product. Product delay will move the label placement in time (00.000). Because the product delay feature utilizes time, the speed of the product MUST be constant and consistent. This section will explain how to apply more than one label to a single product with a single start signal. MULTIPLE FEED will allow you to select how many labels to be applied.

1. Set basic applicator up first, refer to quick setup
2. Ensure that applicator is operating properly before starting this procedure.
3. Set Product delay to 00.000
4. Start system and apply label at the desired speed.
5. Check the placement of the label on the product.
6. Measure the OFFSET of the label placement. Note: A label CAN NOT be advanced on the product ONLY moved "back" since the applicator can only delay the product signal.
7. Apply a small delay to the product delay or if too great, it may be necessary to physically move the product switch. Keep product delays to a minimum for best results.
8. Operate system again and measure offset.
9. Apply a small delay to the product delay or reduce if too much.
10. Test again; repeat if necessary until label is in proper registration.
11. Go to **MULTIPLE FEED** in PRODUCT SENSOR menu and set the number of labels to be applied to the product.
12. Set the Distance between each label entering a time (0.000) into "**INTERVAL DELAY**"
13. Test the placement of the labels and adjust as necessary. Note: The spacing between each label will be equal. With this feature the space between labels **can not** be set individually.
14. Note: **TRAILING EDGE TRIGGER** will NOT work with this feature!
15. Note: Product speed fluctuations can effect label placement.
16. Turn back on any options that may have been disabled for setup of this particular feature.

HOW TO SET UP A VARIABLE DATA APPLICATION

- **“TAMP” WITH TWO TRIGGER PHOTO EYES**

Variable data application is utilized when the LM3605 is interfaced with a scale or other equipment that will be transmitting a DIFFERENT label format to the applicator for every label that is applied. When this option is activated, the use of the **pre-print photo eye (option) is required**. The pre-print photo eye will trigger the printing of the label. The product photo eye (switch) will trigger the application (tamp) of the label. The reason for two triggers is to improve the accuracy of the label placement when **printing before applying**.

General set up

1. The PRE-PRINT photo eye connects to the AUX 2 port.
2. The PRE-PRINT photo eye should be set to trigger on the leading edge of the product.
3. The PRE-PRINT photo eye should be set to trigger BEFORE the product switch.
4. The PRE-PRINT photo eye should be set to allow the printer enough time to print the format before the product switch is activated.
5. The PRODUCT DELAY should be kept to a minimum.
6. With this feature only work with the cycle type set to “tamp after feed’ and only with “leading edge trigger”.

Determine the following and select it in the software

- **“TAMP AFTER FEED”**
1. Set Product Sensor to leading edge.
 2. Set Cycle type to tamp after feed.
 3. Set print Type to “Variable Data ON”
 4. Enter a value in the tamp duration (start with 00.500)
 5. Set head up limit switch, normally open is standard
 6. Use the product delay to “MOVE” the label on the product

The asynchronous application mode is used to apply labels to products that are either stationary or moving at a constant speed when the label application is to take place.

DESCRIPTION OF I/O

LEGEND

24V OPT: 24V OPTO INPUT WITH INTERNAL 24V COMMON
 OH: HIGH CURRENT OUTPUT Rated @ 500ma

All user inputs and outputs are “**SINKING**” type. Example in order for a status light to illuminate for “Run Status Ok” the light should be wired between pins #2 & #4 on the “**Light Bar/Aux.**” Connector.

Status display legend.

INPUTS				OUTPUTS			
S	P	H	Y	A	F	V	T
SMART TAMP	PRODUCT SENSOR	HEAD UP TAMP SENSOR	AUX OUT #1	AIR ASSIST SOL	FLAG SOL	VACUUM SOL	TAMP SOL

P0.0	PAPER END INPUT	0=ON
P0.1	RIBBON END INPUT	0=ON
P0.2	PRINER ERROR INPUT	0=ON
P0.3	RIBBON NEAR END INPUT	0=ON
P0.4	PRINT END INPUT	0=ON
P0.5	ON-LINE INPUT	0=ON
P0.6	REPRINT OUTPUT	0=ON
P0.7	PRINT OUTPUT	0=ON
P1.3	RED LIGHT ON (GREEN OFF)	1=ON
P1.4	YELLOW LIGHT ON	1=ON
P1.5	LOW LABEL INPUT	0=ON
P1.6	TAKEUP MOTOR OUT	0=ON
P1.7	AUX INPUT (DISABLE)	0=ON
P2.0	NOT APPLICABLE	0=ON
P2.1	NOT APPLICABLE	0=ON
P2.4	VACCUM SOL OUT	0=ON
P2.5	AIR ASSIST OUT	0=ON
P2.6	ROUND MODULE OUT	0=ON
P2.7	FLAG SOL OUT	0=ON
P3.4	TRIGGER INPUT	0=ON
P3.5	HEAD UP SWITCH INPUT	0=ON
P3.6	SMART TAMP INPUT	0=ON
P3.7	PRE-PRINT START INPUT	0=ON

The bit not listed above are used for serial clock data, RS232, and internal functions

LOGIC BOARD

REMOTE TRIGGER CONNECTOR (PRODUCT SWITCH)	P1 PIN #	I/O	ADDRESS
TRIGGER INPUT	1	INPUT	P3.4
+24 VOLT	2		
24V COMMON	3		
SHIELD			

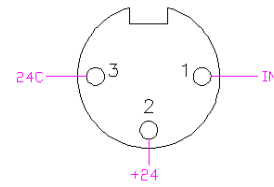

HEAD-UP / AUX IN	P2 PIN #	I/O	ADDRESS
HEAD-UP	1	INPUT	P3.5
+24 VOLT	2		
24V COMMON	3		
SMART TAMP / AUX IN 1	4	INPUT	P3.6
	5		
SHIELD			

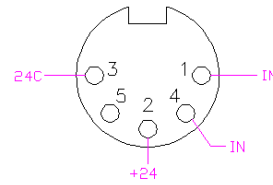

AUX 2	P3 PIN #	I/O	ADDRESS
+5dvc	1		
(GND)	2		
	3		
PRE-PRINT INPUT	4	INPUT	P3.7
24V COMMON	5		
+24 VOLT	6		
SHIELD			

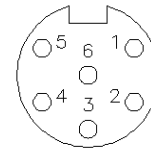

TAMP SOLENOIDS	P4 PIN #	I/O	ADDRESS
	1		
+24 VOLT	2		
	3		
AIR ASSIST SOL 24VDC	4	OUTPUT	P2.5
VACUUM SOL 24VDC	5	OUTPUT	P2.4
TAMP SOL 24VDC (also MTR2 120vac)	6	OUTPUT	P2.6
FLAG SOL 24VDC	7	OUTPUT	P2.7
SHIELD			

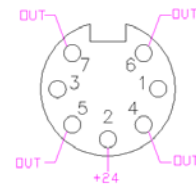

WARNING BEACON / AUX	P5 PIN #	I/O	ADDRESS
LOW LABEL PHOTOEYE 24VDC	1	INPUT	P1.5
+24 VOLT	2		
24V COMMON	3		
RUN STATUS (OK) 24VDC (green light)	4	OUTPUT	P1.3
No connection	5		
LOW RIBBON / LABEL 24VDC (yellow light)	6	OUTPUT	P1.4
ERROR LITE 24VDC (red light)	7	OUTPUT	P1.3
DISABLE LABELER	8	INPUT	P1.7
SHIELD			

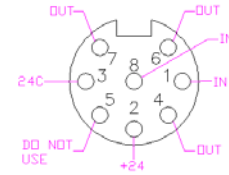

PRINT AND APPLY INTERFACE	P6 PIN #	I/O	ADDRESS
PAPER END	1	INPUT	P0.0
PRINTER GROUND	2		
RIBBON END	3	INPUT	P0.1
PRINTER ERROR	4	INPUT	P0.2
PRINT START	5	OUTPUT	P0.7
PRINT END	6	INPUT	P0.4
REPRINT	7	OUTPUT	P0.6
	8		
ONLINE	9	INPUT	P0.5
	10		
RIBBON NEAR END	11	INPUT	P0.3
	12		
+5vdc from printer	13		
SHIELD			

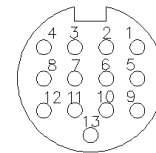

TAKE-UP MOTOR / ROUND MODULE	P7 PIN #	I/O	ADDRESS
	1		
	2		
MOTOR 2 NEUTRAL	3		
	4		
MOTOR 1 120VAC (take-up / round module)	5	OUTPUT	P1.6
MOTOR 2 120VAC (auto-round)	6	OUTPUT	P2.6 / Tamp
	7		
	8		
GND / SHIELD			

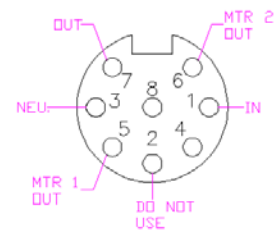

KEYPAD / DISPLAY RS232	P8 PIN #	I/O	ADDRESS
232 XMIT	1		
232 RCV	2		
GND	3		
+24VDC	4		
GND	5		
	6		
	7		
	8		

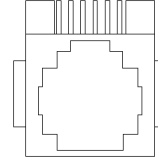

SERIAL AUX RS232	P9 PIN #	I/O	ADDRESS
232 XMIT	1		
232 RCV	2		
GND	3		
	4		
	5		
	6		
	7		
	8		

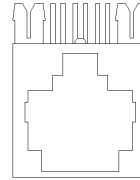

SECTION 4

CLEANING & MAINTENANCE

Troubleshooting	4-01
Fault Codes	4-02
Maintaining the Air Slide	4-03
Replacing the Power Fuse	4-04

TROUBLESHOOTING GUIDE

If the system malfunctions, it is necessary to determine where the problem exists in a normal sequence of operation. The procedure of the unit is outlined in the left hand column of the table below to provide a systematic approach to troubleshooting.

Problem	Possible Cause	Corrective Action
Unit will not turn on.	A. Blown Main Fuse	Check main power fuse and replace if necessary as shown on page. Check printer fuse
Air system will not operate.	A. No air pressure. B. Plugged hose. C. Faulty valve.	Check air supply and filter. Fix or replace hose. Consult factory.
Tamp will not operate.	A. No air B. Plugged hose C. Faulty valve D. Cable E. No tamp duration F. Sticky cylinder	Check air supply and filter Fix or replace hose Consult factory Check connection Reference tamp setup Consult factory
Unit will not print or tamps will not print	A. Unit off line B. Incorrect label configuration C. No label format downloaded D. Wrong interface selected E. Interface cable F. Error on printer	Check printer cover limit switch Check software Check software Check mode Printer Manual Setup Check connection Check printer manual
Take-up unit does not turn.	A. Motor not running B. Friction plate failure in clutch C. Mechanical failure in clutch	Consult factory Consult factory Consult factory
Waste web tension too loose.	A. Clutch tension too low.	Adjust clutch
Waste web breaks or printing drifts on labels	A. Clutch adjusted to tight. B. Machine Webbed wrong. C. Low quality webbing. D. Friction plate failure in clutch. E. Mechanical failure in clutch.	Adjust clutch Re-web system Consult label manufacturer Consult factory Consult factory

FAULT MESSAGES

DISPLAYED FAULT	FAULT	CORRECTIVE ACTION
Memory Checksum	Data lost in serial EEPROM	Consult factory or service provider
Print Time Out	Printer failed to print or Control failed to receive a "End Print Signal"	<ul style="list-style-type: none"> A. Printer Off Line B. No Label Formats Loaded C. Check Printer Interface Cable D. Printer mode incorrect
Tamp Down FLT	Head up limit switch failed to switch during the tamp cycle. Cylinder did not move off of reed switch.	<ul style="list-style-type: none"> A. Tamp Cylinder Is Not Up B. No Air C. Faulty Valve D. Flow Control Miss Adjusted E. Miss Adjusted Reed Switch F. Faulty Reed Switch G. Tamp duration too small H. Check programming of Tamp switch <p>NOTE: Light on reed switch should be on when cylinder is up</p>
Head Down	Head up limit switch failed to switch during the tamp cycle. Cylinder did not return up.	<ul style="list-style-type: none"> A. Tamp Cylinder Is Not Up B. No Air C. Faulty Valve D. Flow Control Miss Adjusted E. Miss Adjusted Reed Switch F. Faulty Reed Switch G. Tamp duration too small H. Check programming of Tamp switch <p>NOTE: Light on reed switch should be on when cylinder is up</p>
2 nd Trigger FLT	Trigger signal was not received before timer expired. This FAULT will only occur if "Variable Data" feature is "ON".	<ul style="list-style-type: none"> A. Check photo eyes B. Check product delay
Ribbon Out	Printer is out of ribbon	Check printer for ribbon
Low Ribbon	Printer is low on ribbon	Check printer for ribbon
Label Out	Printer is out of ribbon	Check printer for label stock

MAINTAINING THE AIR SLIDE

Very little maintenance is required to keep the Tamp Assembly's air slide in good working condition. To maintain the air slide, simply remove the air lines from the air slide and place 1-2 drops of any approved air motor oil into the air inlets at least once a month. 1-2 drops of oil is also required for the incoming air supply. **WARNING!!!** The main air supply must be shut off before you remove the air lines from the air slide.

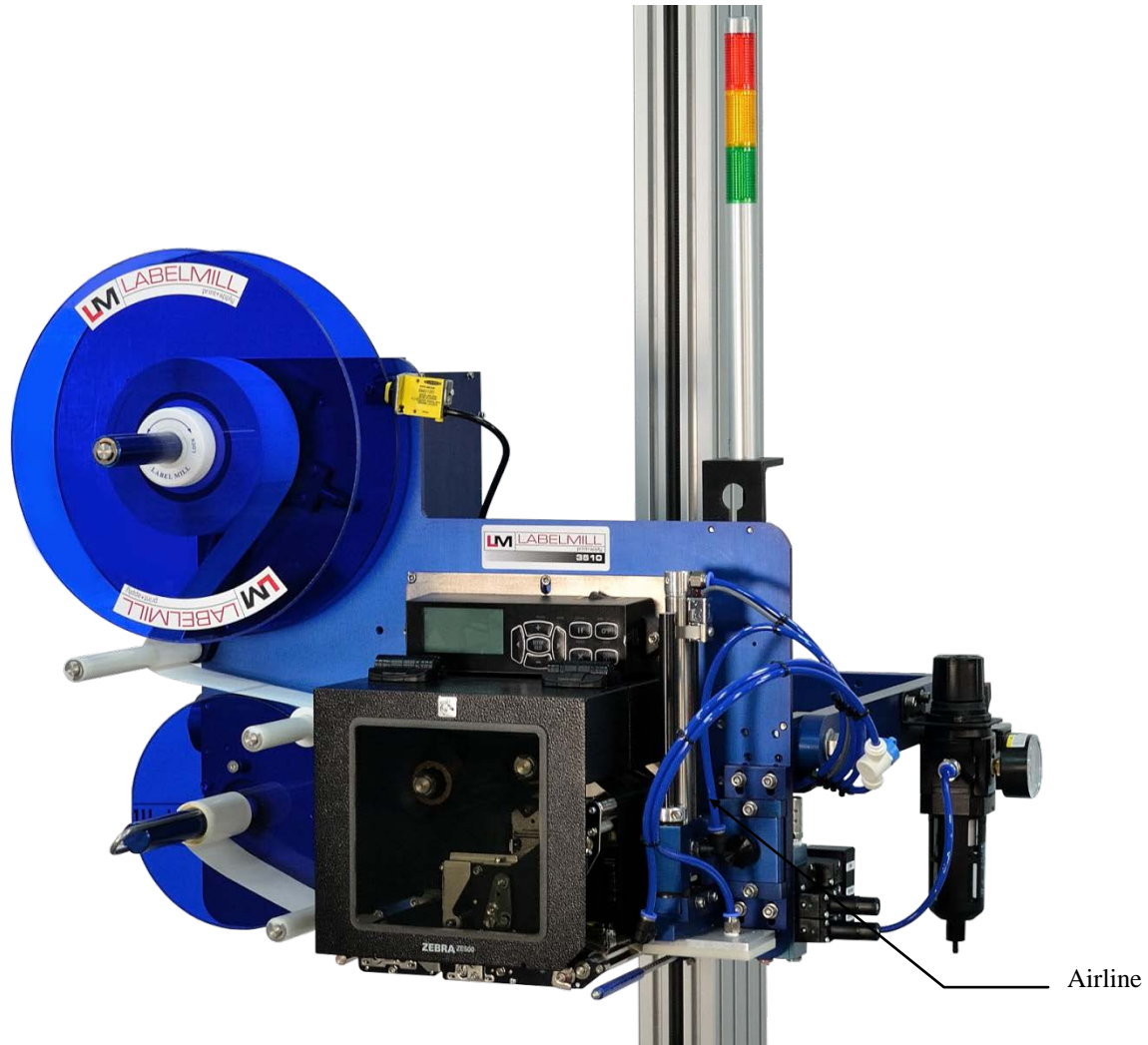

REPLACING THE MAIN POWER FUSE

The circuitry is protected from a current overload by GMA 10A a fast blow fuse. Should the applicator fail to operate, the condition of this fuse should be checked. If the fuse is open, the cause of the overload condition must be determined and corrected prior to replacing the fuse. NEVER replace the fuse with one of a greater AMP rating. The specified rating has been selected to prevent damage and/or injury.

ACTIONS TO REPLACE THE MAIN FUSE

1. Set the main power switch to the OFF position.
2. Disconnect the AC power cable from the rear of the console.
3. Locate the fuse holder / power cord assembly.
4. Gently press down the fuse holder cover while pulling away from the console.
5. Replace with the spare fuse provided in the holder.

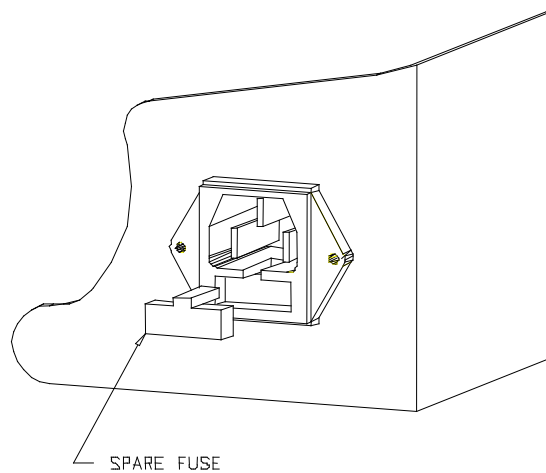

LM3605

PRINT & APPLY

OPERATIONS MANUAL



Copyright and Trademarks

Copyright ©2019
All rights reserved. All trademarks and brand names
are the property of their respective owners.

LabelMill
2416 Jackson St.
Savanna, IL 61074

Phone: (800) 273-4707; Fax (815) 273-7074
www.labelmill.com
info@labelmill.com