

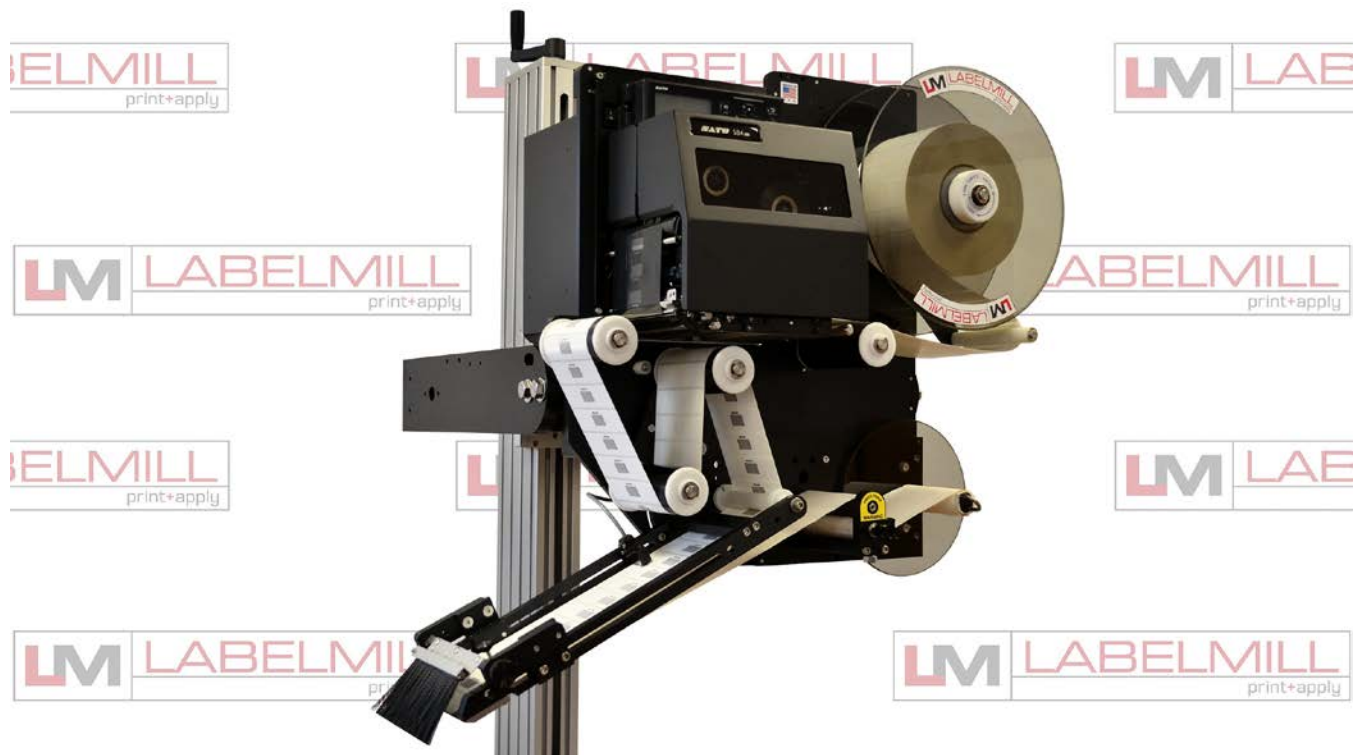

# LM3560

## SERVO DRIVE PRINT & APPLY AUTOMATIC LABEL APPLICATOR OPERATIONS MANUAL



Manufactured in USA by:

**LabelMill, Inc.**

2416 Jackson St.

Savanna, IL 61074

(800) 273-4707

info@labelmill.com

www.labelmill.com

# TABLE OF CONTENTS

SECTION	PAGE
<b>1. APPLICATOR OVERVIEW</b>	
Introduction	1-1
General Applicator Specifications	1-1
Inventory List	1-2
User Responsibility/Safety	1-3
<b>2. WEBBING, SETUP AND GENERAL OPERATION</b>	
LM3560 Component Description	2-1
Web Routing (Synchronous)	2-2
Label Sensor Adjustment	2-3
Drive Motor Pack	2-4
T-150 Mounting Stand (option)	2-5
T-Stand Adjustment	2-6
<b>3. SETUP &amp; ADJUSTMENT</b>	
Optional Valve Pack	3-1
Tamp Assembly & Factory Setup	3-2
Flag Assembly & Factory Setup	3-3
Synchronous Feed & Factory Setup	3-4
Corner Wrap Unit Operation	3-5
<b>4. PROGRAMMING AND CONTROL OPERATION</b>	
Operator Interface Console	4-1
Accessory Connections	4-2
Photo Eye Trigger & Wiring	4-3
Programming	4-4
Programming Flow Chart	4-8
Main Displays	4-10
Key Definitions	4-21
Set Up of Key Features	4-23
Quick Start & Manual Setup	4-28
Input & Output Description	4-33
How To Set Labeler Communications Address	4-39
<b>5. TROUBLE SHOOTING &amp; MAINTENANCE</b>	
General Cleaning & Maintenance	5-1
Troubleshooting	5-2
Fault Codes	5-3
Replacing the Main Power Fuse	5-4

## SECTION 1

# APPLICATOR OVERVIEW

Introduction	1-1
General Applicator Specifications	1-1
Inventory List	1-2
User Responsibility & Safety	1-3

# LABELMILL LM3560

## SERVO PRINT & APPLY LABEL APPLICATOR

The **LabelMill LM3560** is a state of the art, high speed, heavy-duty industrial Label Applicator. High-speed label applications to 2300 linear inches of label web per minute is combined with an exceptional placement accuracy of up to +/- 1/32", with its wipe-on method of application. Products may be labeled in any attitude (top, side or bottom) when used in conjunction with available product handling systems. Outboard-supported drive roller to minimize vibration induced label misplacement. Heavy duty Servo motor drive. Hardened steel peeler plate for reduced wear with high-speed continuous label application. Adjustable label sensor for expediting changeover without sacrificing accuracy. The **LM3560** is transferable from one production line to another when mounted on the **LabelMill Model T-150 Stand**. The **Model LM3560** Applicator is of modular design and features rapid changeover from a wipe-on system to a tamp system using the same applicator platform and controller. The microprocessor controls the servomotor for accurate and consistent label placement. The control has a digital LCD display and key pad for ease of set-up to include RPM, product delay, batch count, total count, tamp duration and more.

### SPECIFICATIONS

<b>Size:</b>	26"H x 32"W x 26"D Weight – 100 lbs.
<b>Electrical:</b>	115V AC, 60 Cycle, 10 amps
<b>Product Sensing:</b>	Photoelectric or mechanical limit switch
<b>Label Roll Size:*</b>	12" O.D., wound on 3" I.D. core
<b>Labeling Speed:</b>	1600 linear inches of web per minute standard (2300 optional)
<b>Label Style Requirements:</b>	Die-cut, waste removed, with minimum of 1/8" separation between labels in running direction
<b>Label Placement accuracy:</b>	Up to +/- 1/32" when labels are produced to specifications and product handling is controlled
<b>Options:</b>	Right or left handed Wipe-On, Tamp Unit or Corner Wrap*
<b>Standard Label Sizes:*</b>	4.1" wide, 12" long

\*Optional lengths and sizes available

\*Customs Available

## INVENTORY LIST

<b>QTY.</b>	<b>Description</b>
1	Applicator Assembly
1	Thermal Transfer Print Engine
2	12-½" dia. Blue Plastic Spools w/ Quick Release Collar
1	7-¾" dia. Blue Plastic Spool w/ screws
2	½" – 13 bolts w/ washers
1	6' Power Cord
1	Product Switch ( Manual Limit Switch/Photo Switch as Specified )
1	Take-Up Spool Clip
1	Label Sensor
1	LM-3560 Control Enclosure
1	Motor Cord
1	Peeler Arm Assembly w/ 2 (¼-20) Screws
1	Model LM3560 Operators Manual

## USER RESPONSIBILITY

This equipment will perform in conformity with the description thereof contained in this manual and accompanying labels and/or inserts when installed, operated, maintained, and repaired in accordance with the instructions provided. This equipment must be checked periodically. Defective equipment should not be used. Parts that are broken, missing, plainly worn, distorted, or contaminated should be replaced immediately. Should such repair or replacement become necessary, we recommend that a request for service advice be made.

This equipment or any of its parts should not be altered without the prior written approval of MM2, Inc. The user of this equipment shall have the sole responsibility for any malfunctions which results from improper use, faulty maintenance, damage, improper repair or alteration by anyone other than MM2, Inc. or a service facility designated by MM2, Inc.

## SAFETY

Only qualified personnel should use this equipment.

Before installing, inspecting or servicing equipment, turn OFF all power and air controls at the source and lock out in accordance with OSHA Standards.

Be sure all external electrically conductive parts are connected to a good electrical ground.

Never handle live electrical equipment with bare hands while standing in water, or while hands and feet are wet. Dangerous electrical shock can result.

Whenever the equipment is unattended, turn off all control and power supply switches.

Keep equipment clean and in good operating condition. Promptly repair or replace all worn or damaged hoses, cables or parts.

Do not make any repairs to equipment unless you are fully qualified.

This equipment contains fast moving parts, which may move without warning. Keep hands, loose hair and clothes clear of machines at all times.

Never place hands or any other body parts under the label platen at any time.

This equipment uses compressed air. Proper care and maintenance must be taken when handling compressed air and its components.

These precautions are further detailed and explained where specifically required in this manual.



### READ AND UNDERSTAND THESE INSTRUCTIONS

Protect yourself and others. Be sure this information is read and understood by all operators.

#### **ELECTRICAL SHOCK CAN KILL!**

Do not touch live electrical parts with bare skin or work with gloves or wet clothing.

#### **NOISE CAN DAMAGE HEARING!**

Wear proper ear protection.

---

## SECTION 2

# WEBBING, SETUP AND GENERAL OPERATION

<b>LM3560 Component Description</b>	<b>2-1</b>
<b>Web Routing (Synchronous Feed)</b>	<b>2-2</b>
<b>Label Sensor Adjustment</b>	<b>2-3</b>
<b>Drive Motor Pack</b>	<b>2-4</b>
<b>T-150 Mounting Stand (option)</b>	<b>2-5</b>
<b>T-Stand Adjustment</b>	<b>2-6</b>

## COMPONENT DESCRIPTION

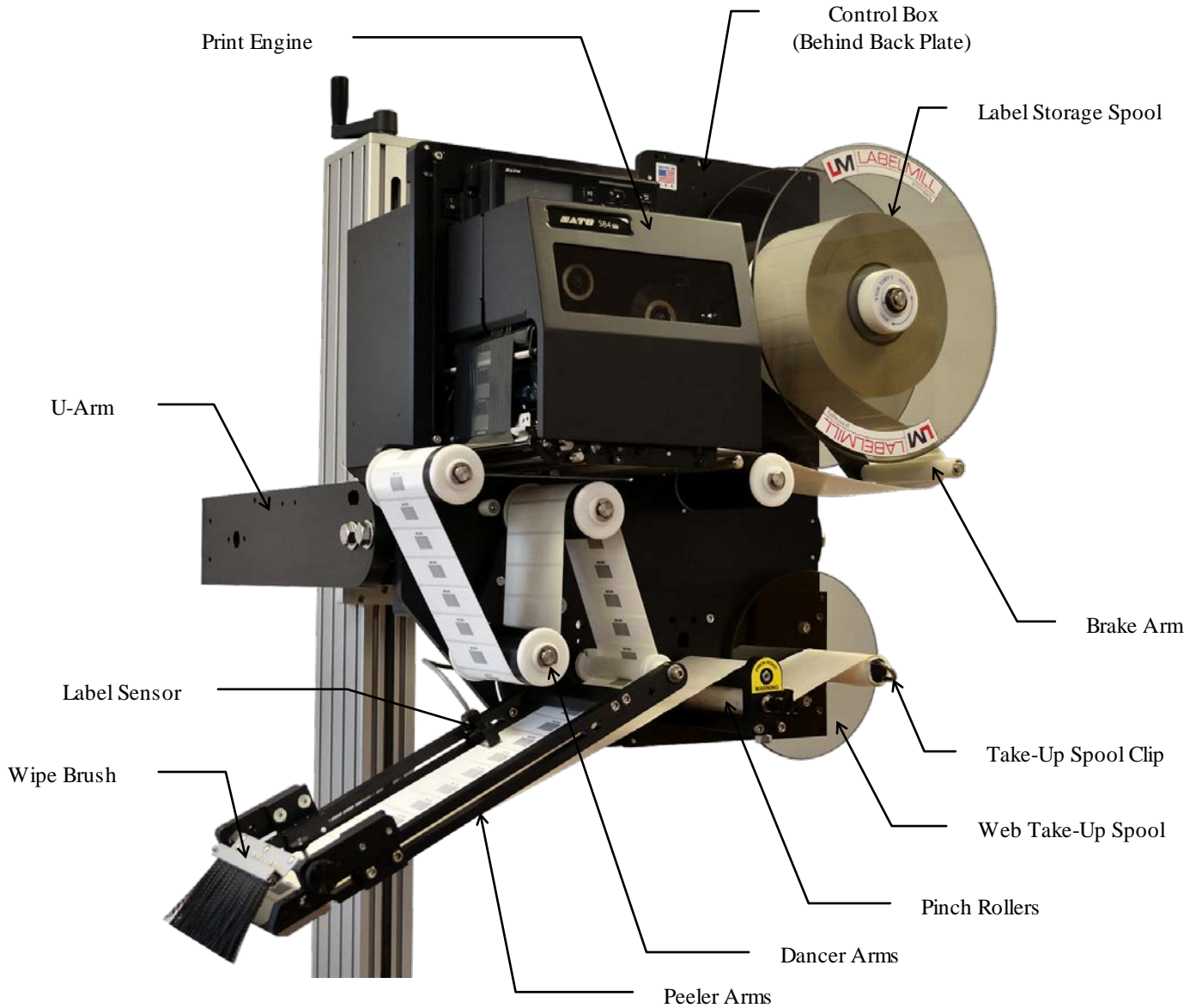



## WEB ROUTING (Left Hand Synchronous Feed Shown)

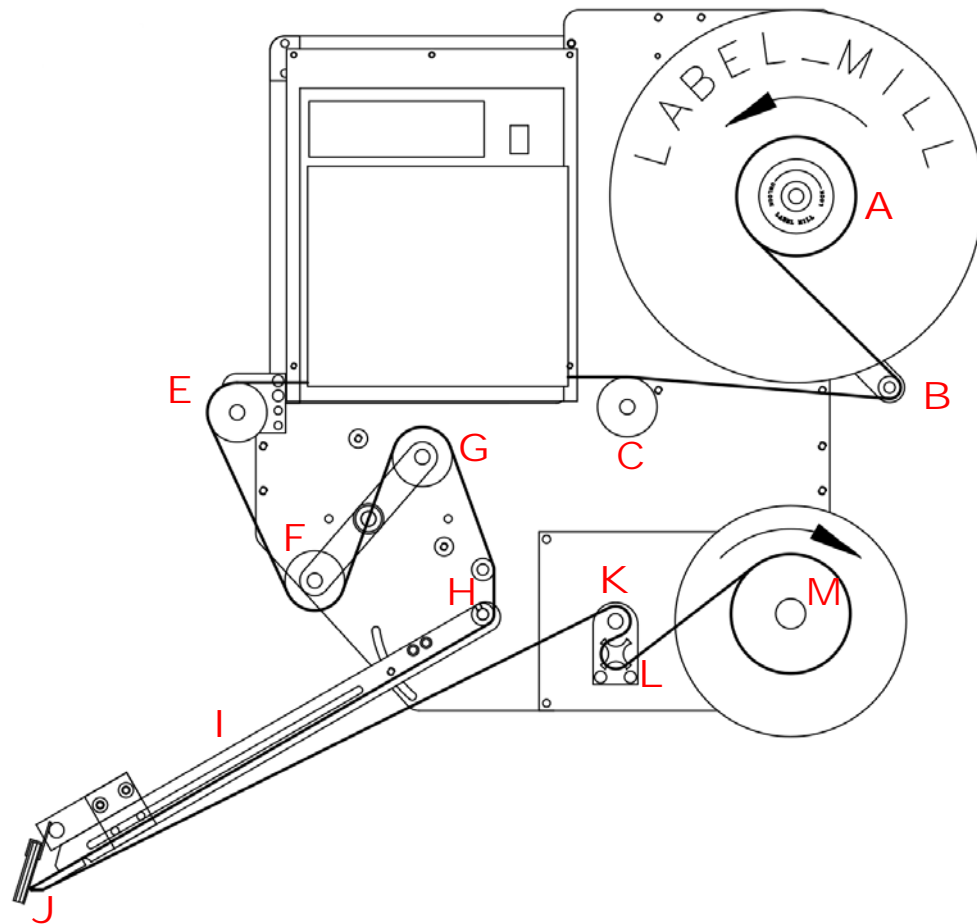

Step	Operation
1	Load web onto label storage spool (A) so it unloads in a counter-clockwise direction.
2	Feed the web to the right and under the brake arm (B), and over guide roller (C).
3	Feed the web through the print engine (D), following the path for your specific engine.
4	Feed the web over roller (E), and around dancer rollers (F) & (G).
5	Feed the web under roller (H), through the label sensor (I), and around the peeler plate (J).
6	Feed the web over the top of drive roller (K). Next, slip the web between the drive roller and the pinch roller (L). Continue on by wrapping the web under the pinch roller.
7	Feed the web over the top drive roller (E). Next, slip the web between the drive roller and the pinch roller (F). Continue on by wrapping the web under the pinch roller (F).
8	Finish the process by loading the waste backing paper onto the web take-up spool (M). Install the take-up spool clip over the end of the waste backing paper.

\*\* To remove the label storage spool (A), turn the spool lock counterclockwise until you reach a stop. The spool will now slide off. To secure the spool, simply turn the spool lock clockwise until snug. DO NOT over tighten!

## LABEL SENSOR ADJUSTMENT



Web  
Sensor

Peeler Arm  
Rail

Manual adjustment of the label in relation to the peeler plate is achieved by loosening the thumbscrew on the backside of the label sensor and sliding the assembly up or down on the peeler arm rail.

Once the label sensor is manually adjusted, trigger the applicator to test the position of the label in relation to the peeler plate.

After the “rough” adjustment is made, refer to page 4-14 for label sensor fine adjustments.

## DRIVE MOTOR PACK (PN: AC-F-A0011)

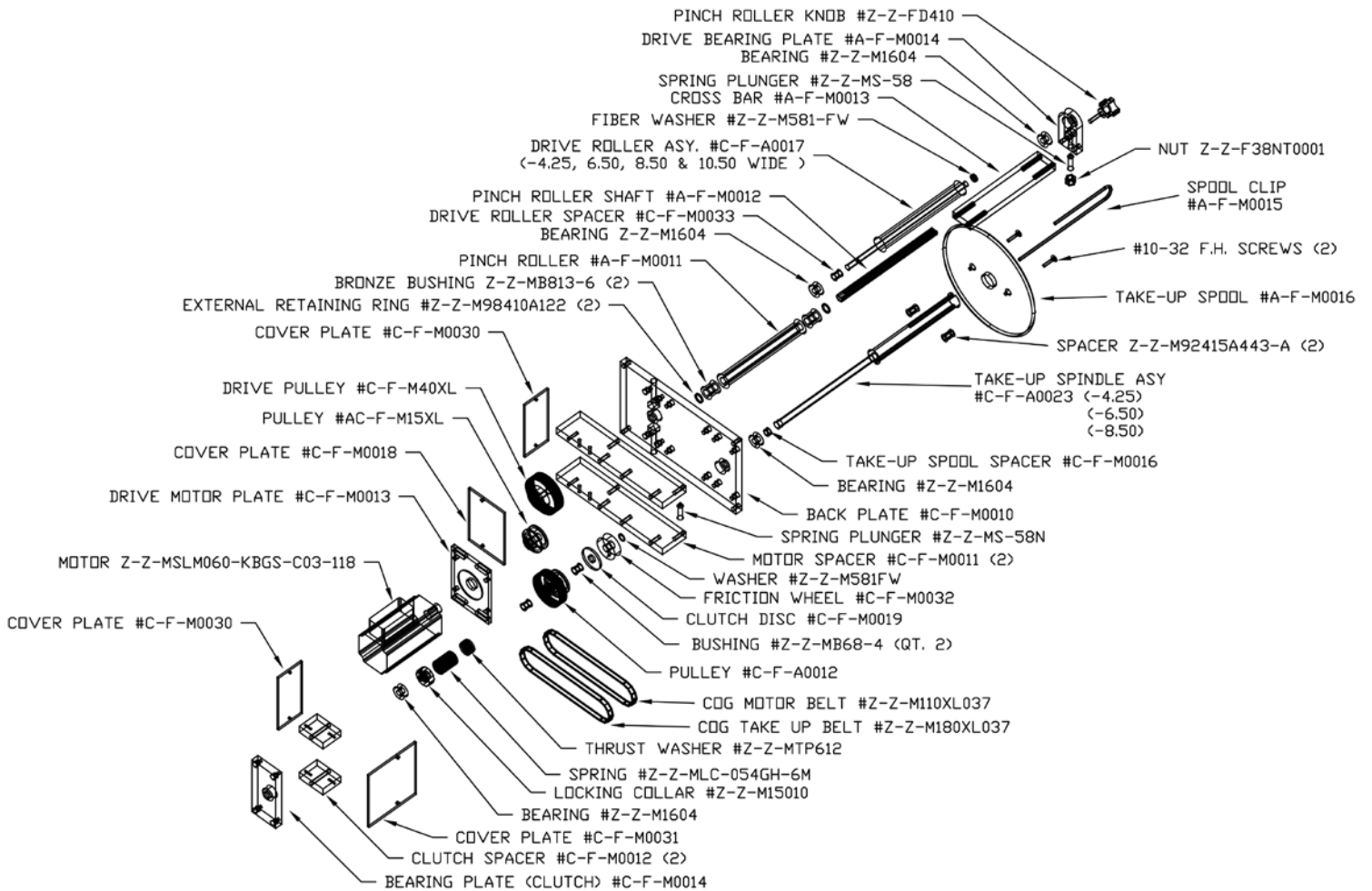

To increase waste web tension, move the lock collar 1/32" away from the take-up spool, compressing the spring.

**CAUTION!** Too much web tension may cause web breakage, label drifting or premature failure of the take-up spool assembly.

## T-150 MOUNTING STAND (OPTIONAL)



## T-STAND ADJUSTMENT

Column Crank



Column Lock



To adjust the T-150 mounting stand, simply loosen the headlocks and adjust to the desired height by turning the column crank. Be sure to lock the headlocks when finished.

## SECTION 3

# SETUP & ADJUSTMENT

<b>Valve Pack</b>	<b>3-1</b>
<b>Tamp Assembly &amp; Factory Setup</b>	<b>3-2</b>
<b>Flag Assembly &amp; Factory Setup</b>	<b>3-3</b>
<b>Synchronous Feed (Wipe-On) Assembly</b>	<b>3-4</b>
<b>Corner Wrap Unit Operation</b>	<b>3-5</b>

## VALVE PACK (Not Included in Synchronous Feed Configuration)

There are solenoid valves associated with applicators using pneumatics. They are supplied with pre-wired cables that connect to the necessary components.

There is an adjustment for airflow for each valve. This will change the rate at which air will flow through each valve. It may be necessary to adjust each valve for optimum performance after installation. The adjustments are performed as shown below.

(Pictures may not show actual model)

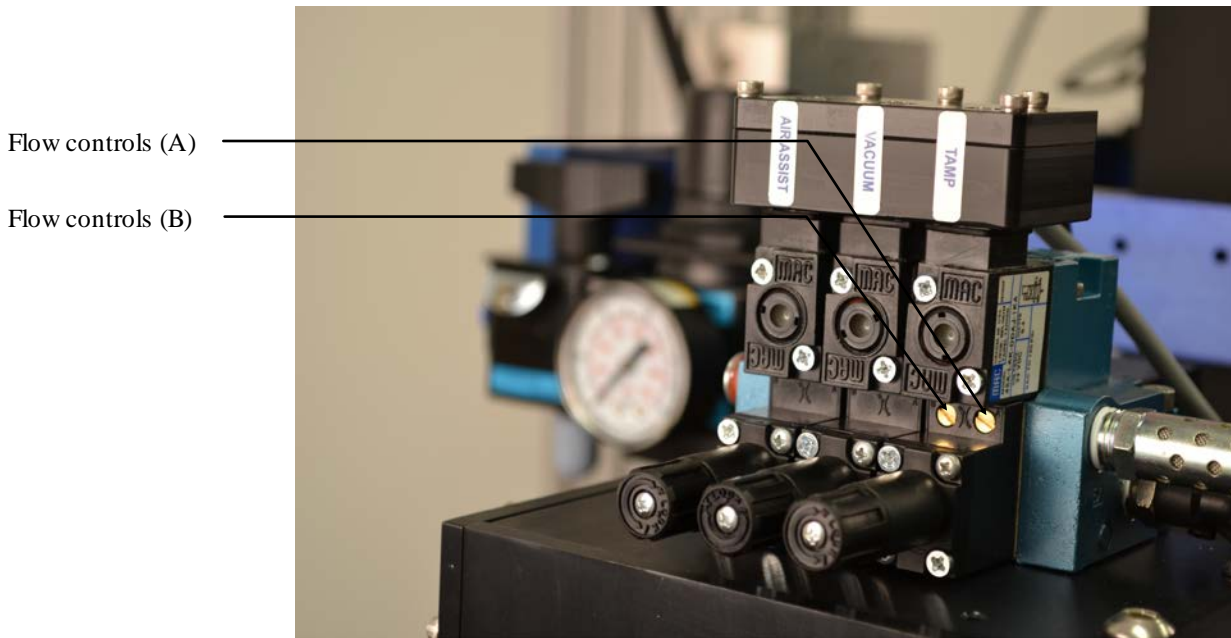

### **FLOW CONTROLS** (Tamp & Corner-Wrap Applications)

Control A: This is used to adjust the speed that the tamp cylinder moves in the upward direction.

Control B: Controls the tamp cylinder in the downward direction.

### **VACUUM REGULATOR**

The vacuum regulator is used to control the vacuum that is used to hold the label to the flag jaws or the tamp pad.

### **AIR ASSIST REGULATOR**

The air assist regulator is used to change the pressure that is applied to the blow tube. The blow tube is below the front edge of the peeler plate and is used to help “push” the label onto the bottom of the tamp pad or the flag jaws.

### **FLAG REGULATOR (Only present if configured with flag applicator head)**

The flag regulator is used to adjust the pressure that the flag jaws apply to the label as it is applied.

## Tamp Assembly & Factory Setup

**NOTE: PICTURES SHOWN MAY NOT RESEMBLE YOUR MODEL**

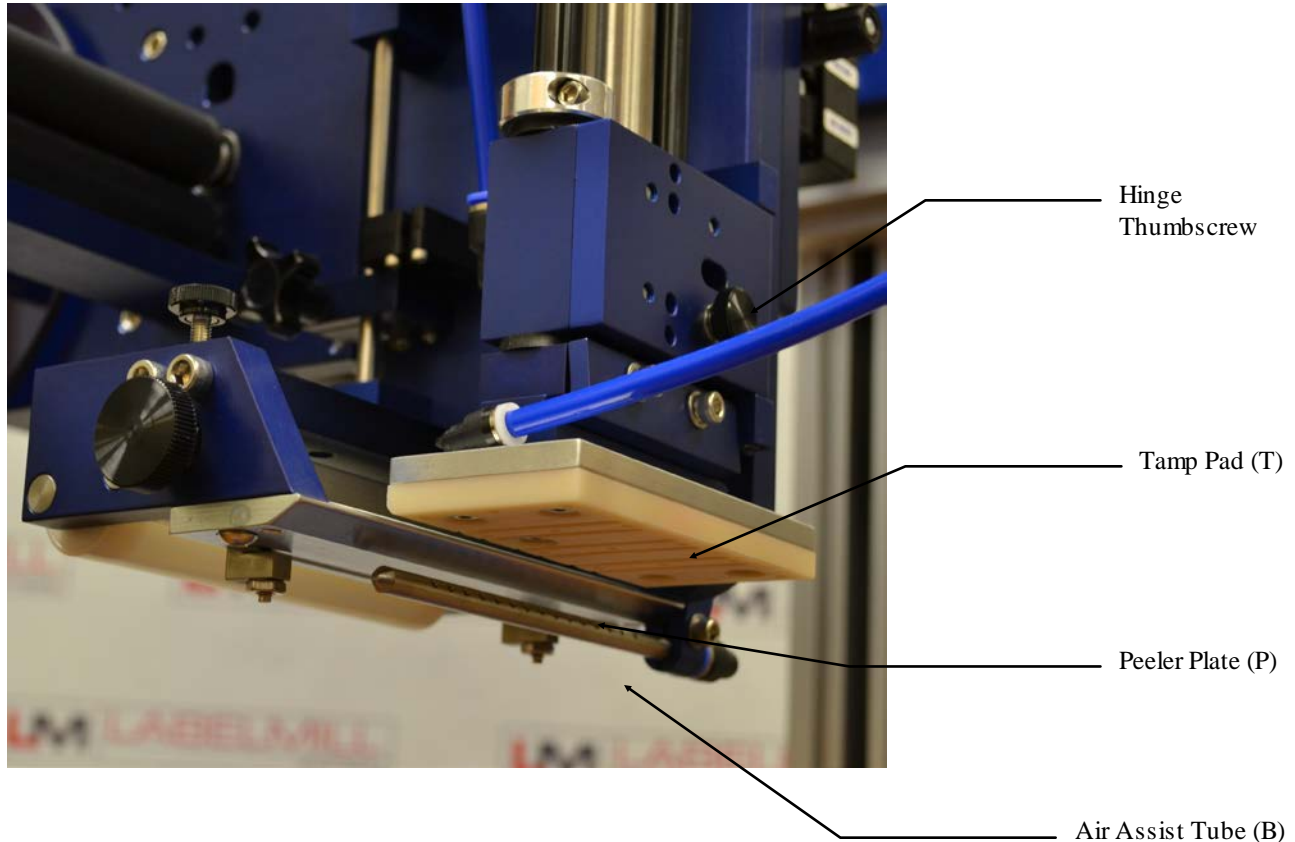

### Tamp pad adjustment

1. To adjust the tamp pad (T) in relationship to the peeler plate (P) in the horizontal plain, loosen the (2) button-head screws and move the peeler plate forward or backward in the slots. There should be approximately 0.020" (A) gap between the tamp pad (T) and the peeler plate (P).
2. To adjust the tamp pad (T) in relationship to the peeler plate (P) in the vertical position, loosen the hinge thumbscrew, swing the tamp assembly out, and loosen the (4) cap head bolts that secure the tamp mount assembly in place. Adjust the up or down to achieve the 0.020", tighten the (4) bolts, and secure the tamp assembly in place by tightening the thumbscrew. This adjustment is very important! If this is not adjusted properly, the label will run into the back of the tamp pad (T) and fold or bunch up.

### Air assist tube adjustment

1. Adjust the air assist tube (B) so that the small holes aim towards the center of the tamp pad. The air assist tube (B) aids the label to adhere to the bottom of the tamp pad (T). Once the label (L) is "blown" onto the tamp pad (T), it is held there by vacuum.
2. Once the above adjustments are made, adjust the vacuum regulator, the air assist regulator, and the flow controls as described on page 3-1.

Note: Too much pressure on the air assist will cause the label to flutter and/or blow off of the vacuum platen.



## Flag Assembly & Factory Setup

**NOTE: PICTURES SHOWN MAY NOT RESEMBLE YOUR MODEL**

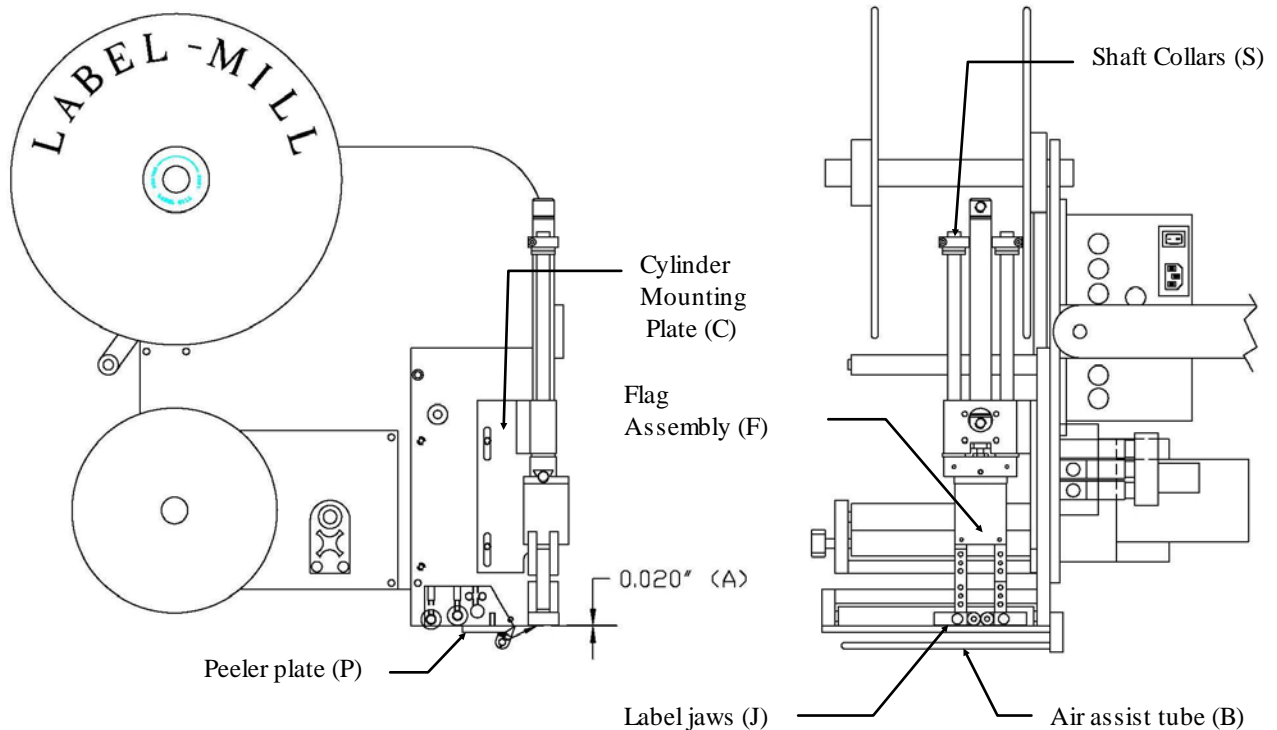

### Label jaw to peeler plate clearance and maximum cylinder travel

To adjust the label jaws (J) in relationship to the peeler plate (P), the cylinder mounting plate (C) and the shaft collars (S) must be adjusted accordingly. The cylinder mounting plate (C) is used to adjust the gap between the peeler plate and the label jaws (A). The shaft collars (S), along with the air valves, are used to adjust the label jaws maximum travel.

1. To adjust the label jaws to peeler plate clearance (A), loosen the two button head cap screws and adjust the cylinder mounting plate to reach the desired 0.020" (A) clearance.
2. After this is set, retighten the cap screws. The dimension (A) should now be double-checked to insure proper clearance. This adjustment is very important! If this is not adjusted properly, the label will run into the back of the label jaws (J) and fold or bunch up.

### Air assist tube adjustment

1. Adjust the air assist tube (B) so that the small holes aim towards the center of the label as shown by the arrowhead shown above. The air assist tube (B) aids the label to adhere to the bottom of the label jaws (J). Once the label is "blown" onto the label jaws (J), it is held there by vacuum.
2. Once the above adjustments are made, adjust the vacuum regulator, the air assist regulator, and the flow controls.

Note: Too much pressure on the air assist will cause the label to flutter and/or blow off of the vacuum platen.

## Synchronous Feed Assembly & Factory Setup



### Peeler Plate Adjustment (used to adjust tracking)

1. Loosen the mounting screws (S) and slide the peeler plate (P) in the direction needed to make the label web track in the desired direction.
2. Retighten the mounting screws (S) to secure the peeler plate (P) after adjustments are made.
3. Now that the plate is adjusted, test run the machine to see if the web tracks correctly.

NOTE: If the web tracks towards the back plate, adjust the end of the peeler plate (P) that is closest to the back plate away from the back plate or the opposite end toward the back plate. Adjust the peeler plate (P) in the opposite direction if the web tracks away from the back plate.

## CORNER WRAP UNIT OPERATION

The LM-3560 control unit is equipped to support the optional corner wrap unit.

(Pictures may not show your actual model)



## SECTION 4

# PROGRAMMING AND CONTROL OPERATION

<b>Operator Interface Console</b>	<b>4-1</b>
<b>Accessory Connections</b>	<b>4-2</b>
<b>T-50 Photo Eye</b>	<b>4-3</b>
<b>Programming</b>	<b>4-4</b>
<b>Programming Flow Chart</b>	<b>4-8</b>
<b>Main Displays</b>	<b>4-10</b>
<b>Key Definitions</b>	<b>4-21</b>
<b>Set Up of Key Features</b>	<b>4-23</b>
<b>Quick Start &amp; Manual Setup</b>	<b>4-28</b>
<b>Input &amp; Output Description</b>	<b>4-33</b>
<b>How To Set Labeler Communications Address</b>	<b>4-39</b>

# HAND HELD LABELER INTERFACE HLI-100

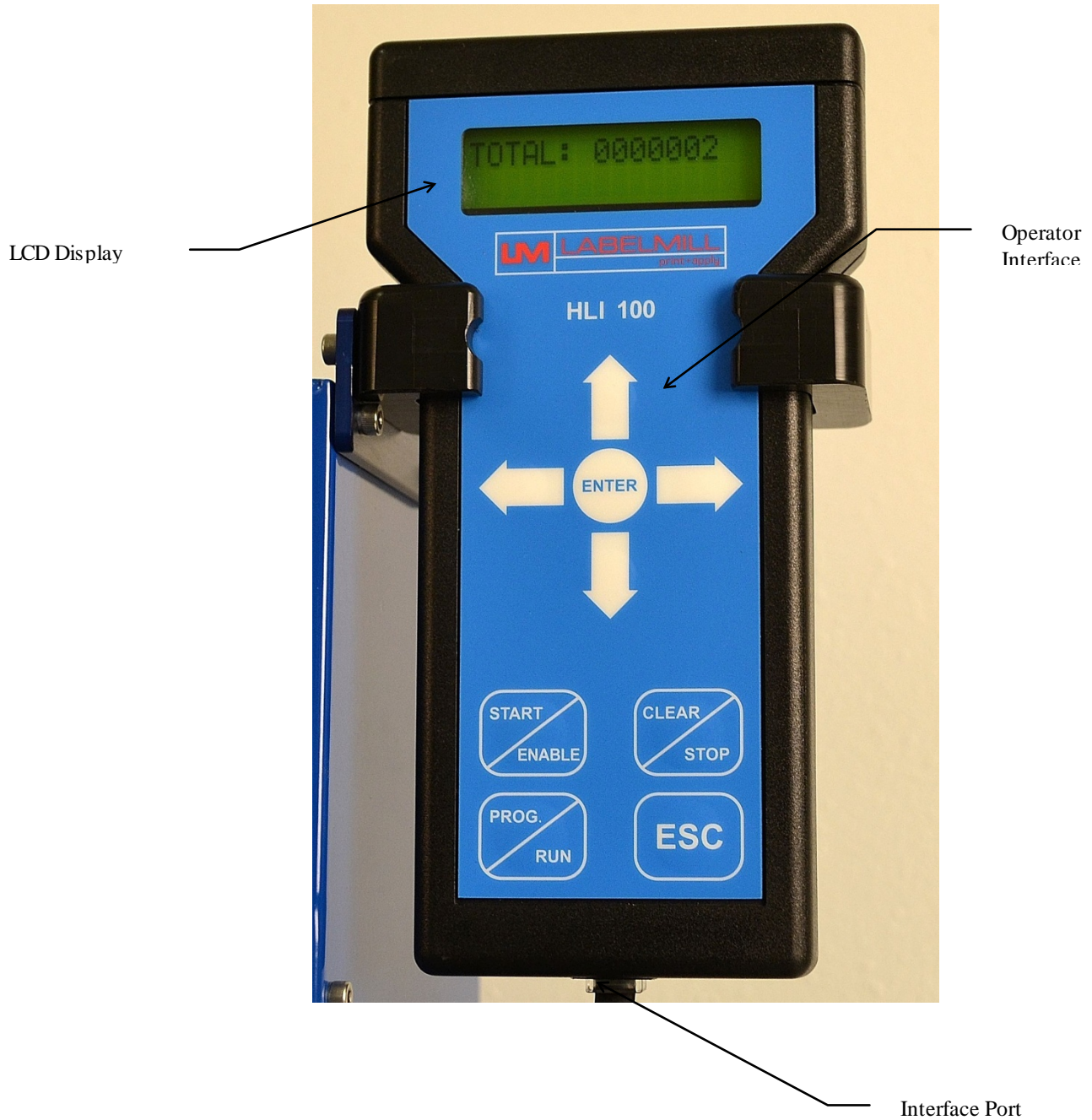

# ACCESSORY CONNECTIONS

## LOCATED ON BACK OF CONTROL BOX

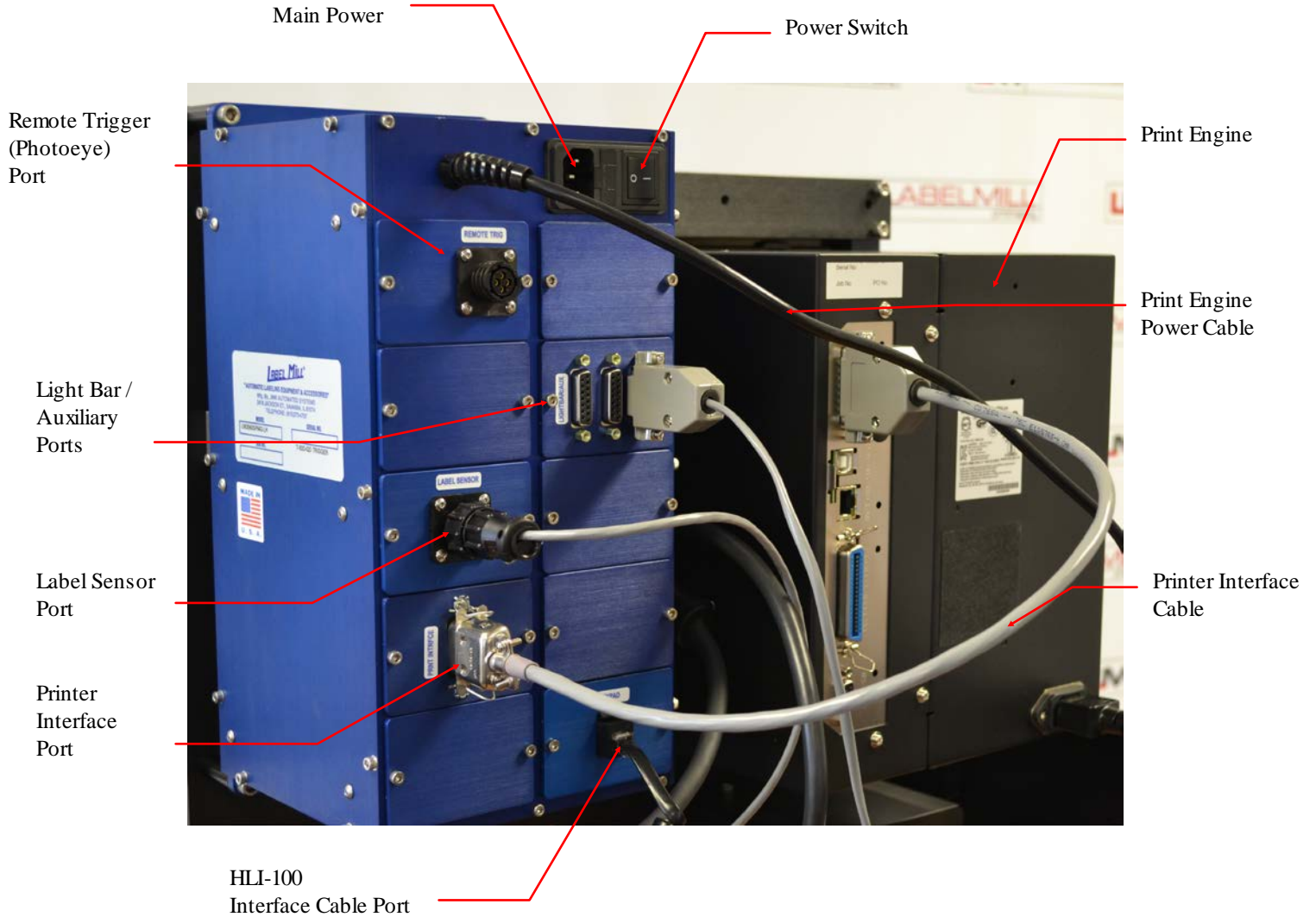

## T-50 PHOTOEYE



### Trigger Cable Wiring

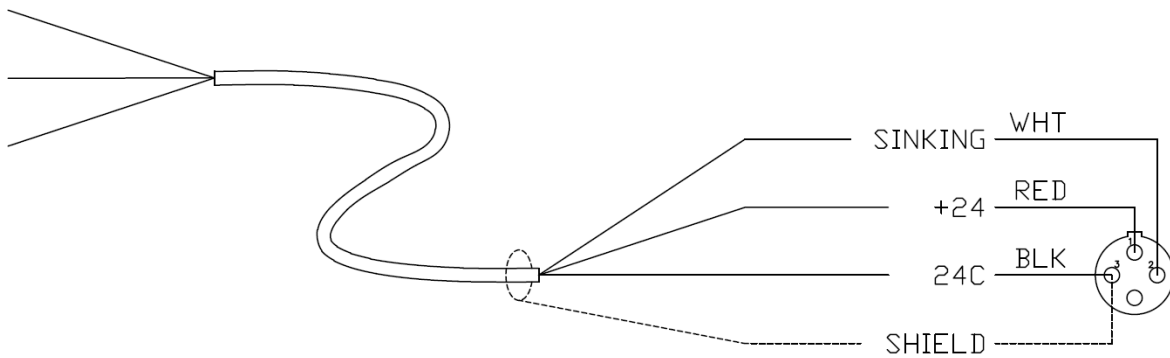

## PROGRAMMING

All programming is performed via the **HLI-100** keypad and display as shown on page 4-1. All programmed settings are backed in nonvolatile memory and are not lost when the unit is powered off.

Upon power up of the control, the screen will display *MODEL NUMBER & REVISION* of the HLI-100 and then the *MODEL NUMBER & REVISION* of the labeler control. After this, the screen will now display the counter, *TOTAL XXXXXXXX*.

- **KEY FUNCTIONS:**

“**PROG**” PROGRAM KEY IS USED TO:

1. **Enter and exit** the program menu.

“**ENTER**” KEY IS USED TO:

1. Access or “Enter” the selected “PROGRAM BLOCK”. (example PRODUCT SENSOR or TAMP SETUP)
2. Access or “Enter” the ***data selection/options*** line (bottom line of display) of the “PROGRAM BLOCK” ***Sub Menus***.
3. Store the selected data.

**UP / DOWN ARROW** KEYS ARE USED TO:

1. Scroll up & down through the primary menu “PROGRAM BLOCKS”. (Header name)
2. Scroll ***sub menus*** inside of “PROGRAM BLOCKS”. (top line of display while ***IN*** a “PROGRAM BLOCKS”)
3. Increment and decrement programmable values.
4. Select different display views while in the “RUN” mode.

**Left / Right ARROW** KEYS ARE USED TO:

1. Move the “up carrot” left or right when programming a value.

**START / ENABLE** KEY:

1. Start key will initialize the application cycle.
2. Enable key will “Enable” the drive after it has been disabled.

**CLEAR / STOP** KEY:

1. Stop key will abort the cycle only when not in the program menu.
2. Clear key will delete stored values while in the edit mode.
3. Clear key will disable the drive.

**ESC (escape)** KEY:

1. Will back out of the sub programming menu without saving changes.



## • PASSWORD

The PASSWORD is used to lock the menus of the control. This option is used to prevent unauthorized access to variable data. When shipped from the factory, the password is to 7074 and NO MENUS are locked. The password cannot be changed.

## • AUTO SETUP

The AUTO SETUP function is used to determine the length of the label, gap length, recommended maximum speed, and set label sensor values. (Note that when using a Clear label detector the sensor values are not relevant) In this mode the applicator will feed 2 – 6 labels to auto set parameters explained above.

## • PRODUCT SENSOR

This is an external device that when “activated” starts the application cycle.

### PROGRAMMABLE BLOCKS:

- Product Delay – delays the application of the label (x) seconds after the sensor has been activated \*\*
- Detector Lockout – used with an external encoder to ignore trigger signals for programmed distance
- Sensor Type – used to designate the type of product sensor used, **Normally open** is the standard
- Sensor Trigger – designates whether the product sensor is activated at the leading or trailing edge of product
- On Debounce – programs how long (in seconds) a trigger signal must be received before activating applicator
- Off Debounce – used to ignore trigger signals (in seconds) after a cycle has completed
- Multiple Feed – how many labels are applied to one product with one signal (reset when signal is toggled)
- Interval Delay – amount of time in seconds between multiple fed labels **Note:** only active if quantity 2 or higher
- \*\* Note the product delay feature will not work when the “**Conveyor Lock**” feature is activated, use TRIGGER DISTANCE and or with the **ENCODER turned on** the “INTERVAL DELAY” display will be replaced with DIST 0 to 2, DIST 0 to 3, DIST 0 to 4, etc. the interval between labels will use distance instead of time in this mode.

## • TAMP SETUP

This is used to adjust the different variables related to the tamp cycle.

### PROGRAMMABLE BLOCKS:

- Tamp Duration – used to adjust the time that the tamp cylinder valve is actuated. (00.000 to 30.000)
- Flag Duration – used to adjust the time the flag jaws are held open after label application.(00.00 to 99.99)
- Head Up Switch – type: **normally open**-standard, normally closed, none
- Head Up Debounce – Debounce is used to allow time for the tamp cylinder to settle on return. (00.00 to 01.00)
- Vacuum Release – Used to release label when tamping on light products.
- Vacuum Delay On – Used to reduce label flutter when feeding large labels while tamping.
- Tamp Sync Logic – Used to interface a printer for loop print and apply.

## • LABEL SPEED

This is used to set the speed that the label is fed.

### PROGRAMMABLE BLOCKS:

- Inches per minute – feeds the label at (x) inches per minute.
- Acceleration (MS) – sets the time that the motor takes to achieve full speed in (x) milliseconds.

Note: If acceleration is set too low (Quick) following errors may occur.

## • COUNTERS

Used to reset and set the internal counters of the control.

### PROGRAMMABLE BLOCKS:

- Total counter – resets the total counter to zero.
- Batch counter – resets the batch counter to zero.
- Batch counter set – sets the total number of labels to be applied in 1 batch.
- Life counter – displays the total number of controller cycles, can not be reset.

(Note that when the batch counter expires the batch done output is activated.)

## • LABEL SENSOR

Provides the ability to select different label sensor types and also set the parameters within these sensor types.

### PROGRAMMABLE BLOCKS:

- I-Mark/Gap/CLR – used to select type of label sensor; “I-MARK”, “Gap” & “Clear” labels (special sensor)
- Manual Set Gap – automatically sets the emitter voltage when sensor is held on gap between label stock.
- Gap Threshold – voltage differential needed to trigger control. (sensitivity)
- Label Length – length of the label
- Label Gap Length – length of the gap between labels
- Label Auto Posn – maintains label position on peeler plate at different label speeds automatically.
- Stop Comp Dist – Calculated distance used in the Label Auto position feature.
- Label Stop Posn – electronically adjusts label stop position in reference to the peeler plate point.
- Missing Label Detect – Turns on the missing label alarm & enables the auto advance feature.
- Missing Label Comp – automatically advances the web to compensate for a missing label.
- Labels To Peelr – Number of labels from label sensor to peeler point

## • ENCODER

Provides a more consistent way to apply labels to a product. With this option a distance from the trigger point can be set at which the label is to be applied. Note: optional encoder must be used with this feature.

### PROGRAMMABLE BLOCKS:

- Encoder – used to turn the encoder option on or off.
- Conveyor Lock – locks the applicator speed with the conveyor speed.
- Enc Override – Allows fine-tuning of the ratio of applicator speed to conveyor speed.
- Trigger Distance – used to apply the label a certain distance away from the trigger point.
- Start Comp Dist – Start Compensation Distance used to compensate for variable speed applications.
- Enc lines/inch – tells how many pulses the encoder will count with 1 inch of travel. (25 to 500 counts per inch)

## • CYCLE TYPE

Determines the application type and sequence in relation to the label.

### *PROGRAMMABLE BLOCKS:*

- No Tamp (Used for Synchronous Feed (Wipe-On) Applications)
- Tamp Before Feed - Tamp Cylinder will cycle before a label is fed onto vacuum platen
- Tamp After Feed - Tamp Cylinder will cycle immediately after a label is fed onto vacuum platen
- Blow Before Feed - Blow cycle will activate before the next label is fed onto the vacuum platen
- Blow After Feed - Blow cycle will activate immediately after a label is fed onto the vacuum platen

## • PRINTER SETUP

Provides printer and cycle control when the applicator is loose looped with a print engine

### *PROGRAMMABLE BLOCKS:*

- Printer - On/Off (Selecting "On" will activate the following menu options)
- >=Print Label - Sends a Print Command to the connected print engine
- <=Cycle No Print - Activates a label application cycle without triggering a print command to the engine

**Note:** These options are used to position a printed label to the peeler plate for live production operation

## • ALARMS

Used to trigger an alarm, light, etc. when the web is broken or miss feed of a label.

### *PROGRAMMABLE BLOCKS:*

- Broken Web – used to turn the option on or off. NOTE this feature will not work with a clear label.
- Sense Volt LVL – Sets the voltage level at which the broken web alarm will trigger.
- Feed Error on/off – used to turn on and off the option if so equipped. In order for this option to work, the tamp pad must be outfitted with a special fiber-optic assembly. This will allow the labeler to detect the feed of the label onto the tamp pad and that the label left the tamp pad during the tamp cycle. Should an error in either one of these conditions occur, the error message “FEED ERROR” will be displayed.

## • JOB STORAGE

Used to store frequently used settings pertaining to different labeling jobs.

### *PROGRAMMABLE BLOCKS:*

- Job store – stores settings for last job.
- Job select – allows operator to select 1 of the optional 10 stored jobs.
- Job delete – allows operator to delete a stored job.

## • DEFAULT SETTINGS

This setting will return the controller to the default settings.

## • I/O STATUS

Displays the status of the inputs and outputs.

## • NETWORK SETTINGS

Programs communication values when used with optional network connection module

# PROGRAMMING FLOW CHART

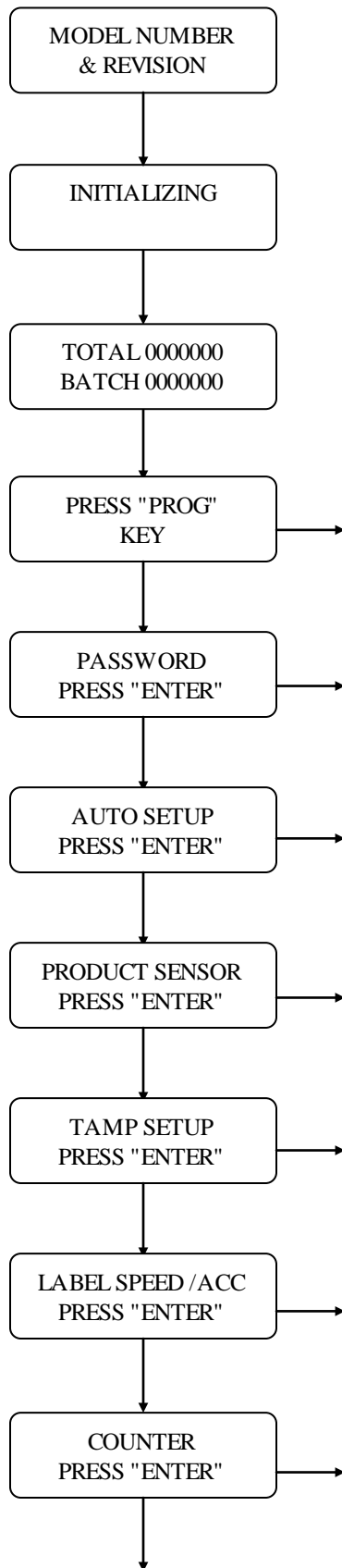

## LM MODEL 3560

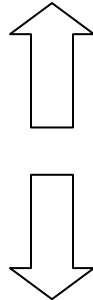

UP & DOWN ARROW  
KEYS WILL SCROLL  
THROUGH THE  
PROGRAMBLOCKS  
AND SUB MENUS

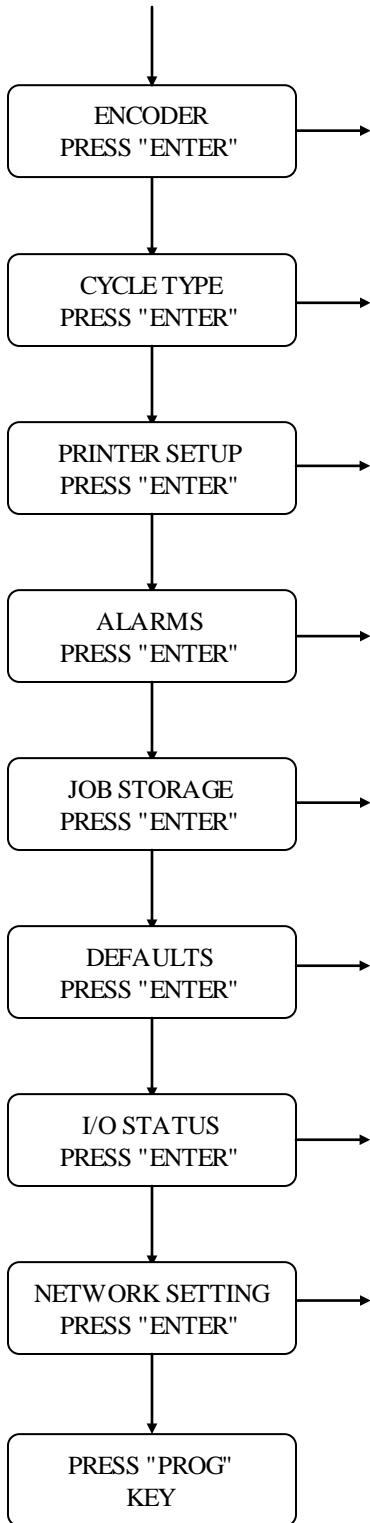

## MAIN DISPLAYS

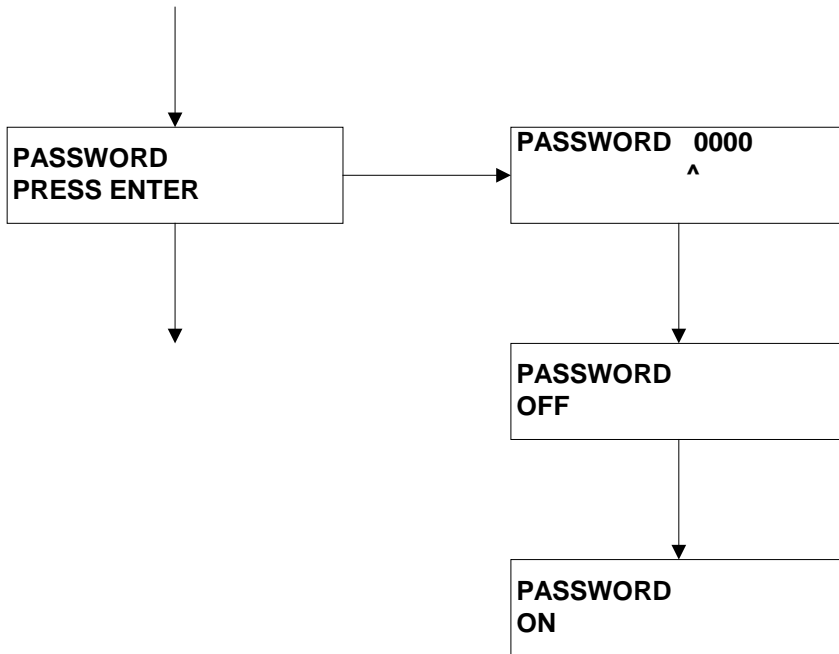

Note: use UP and DOWN arrows to toggle between "ON" and "OFF". The enter key will save selection.

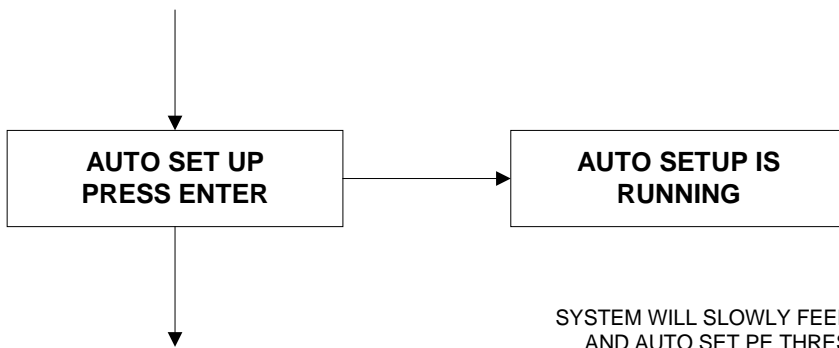

SYSTEM WILL SLOWLY FEED 2-6 LABELS AND AUTO SET PE THRESHOLDS, LABEL LENGTH ,GAP LENGTH , WILL READ OUT MAX SPEED LABEL LENGTH

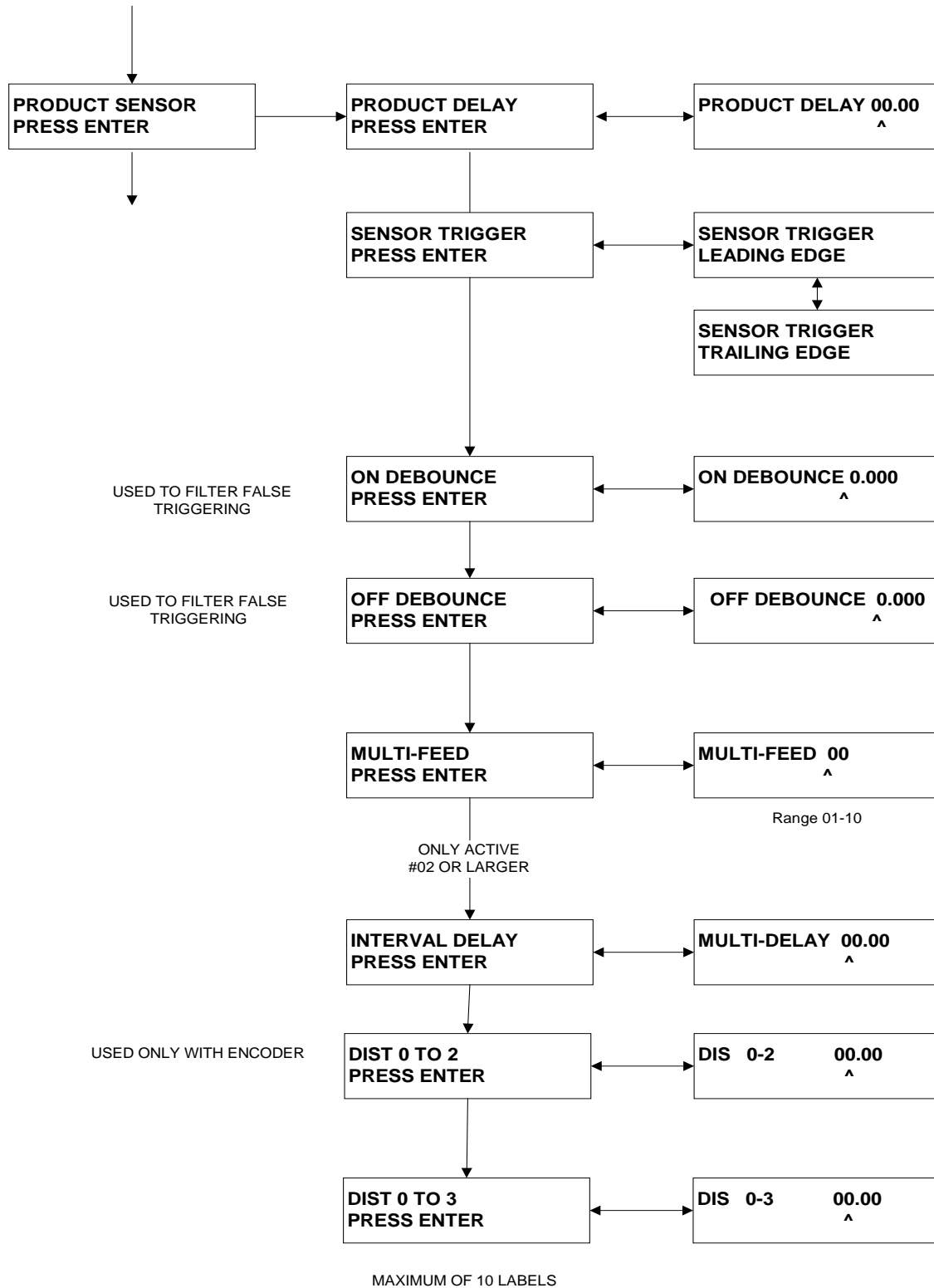

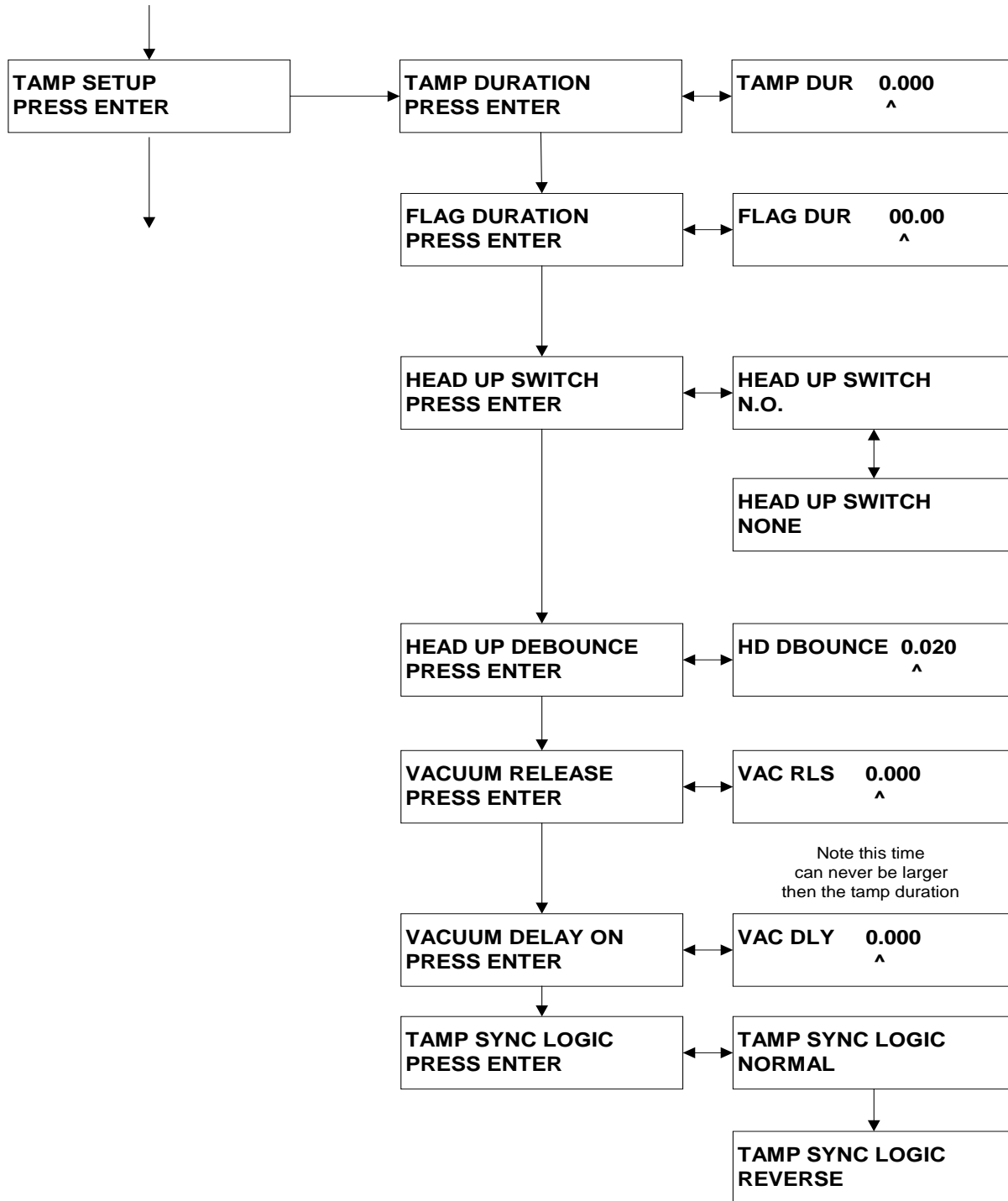



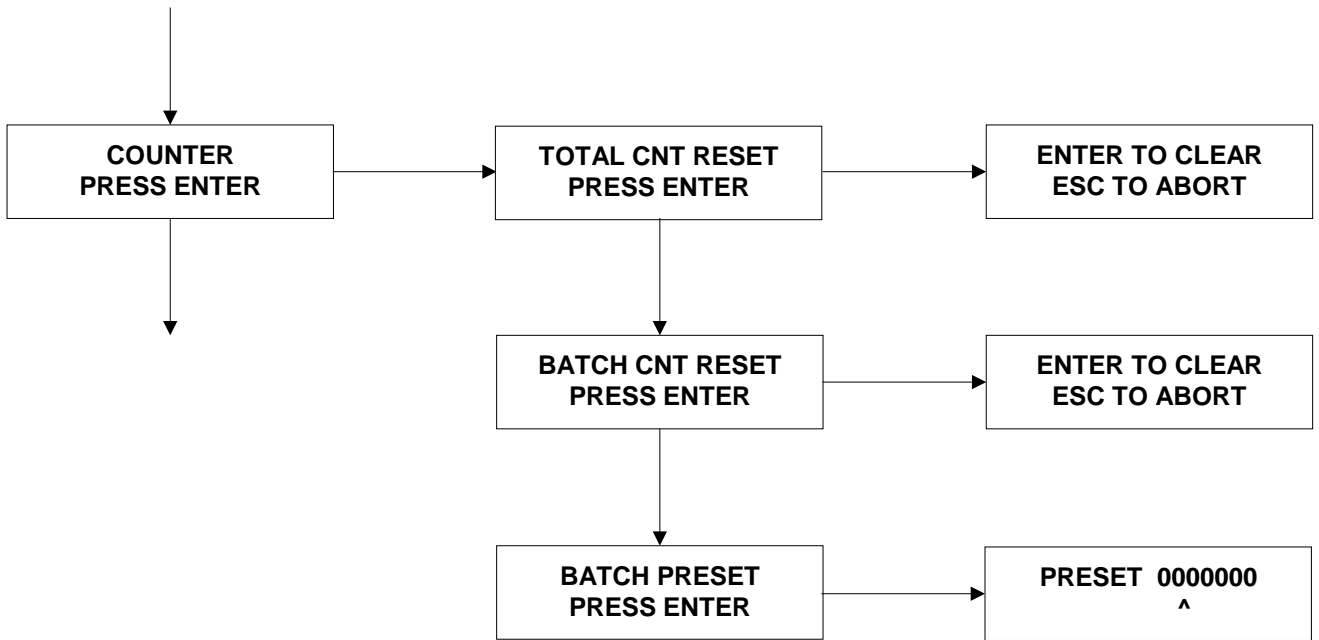
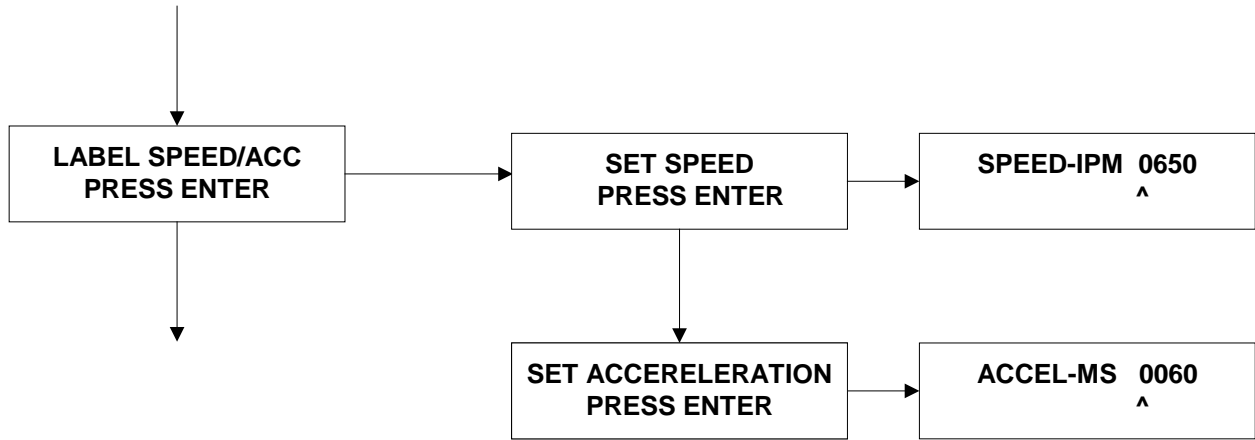

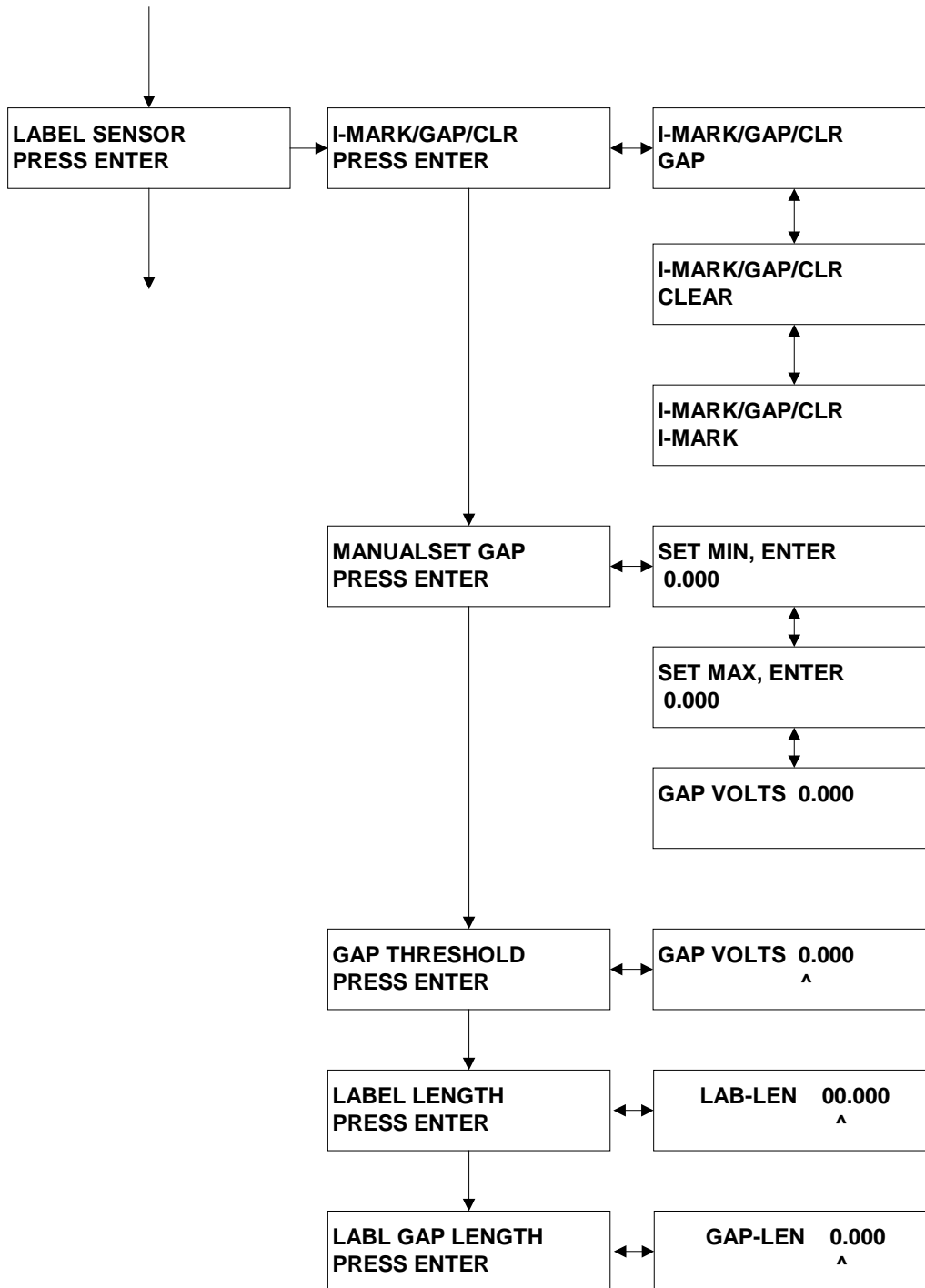

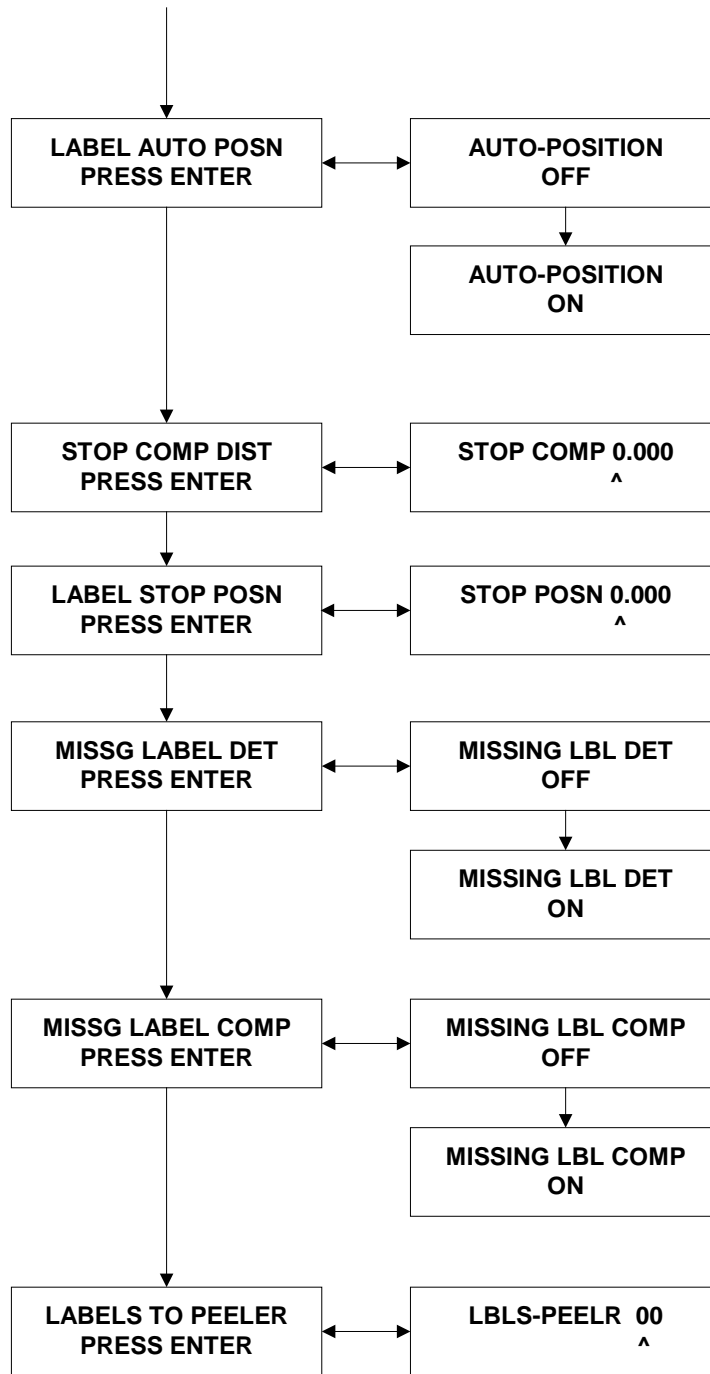

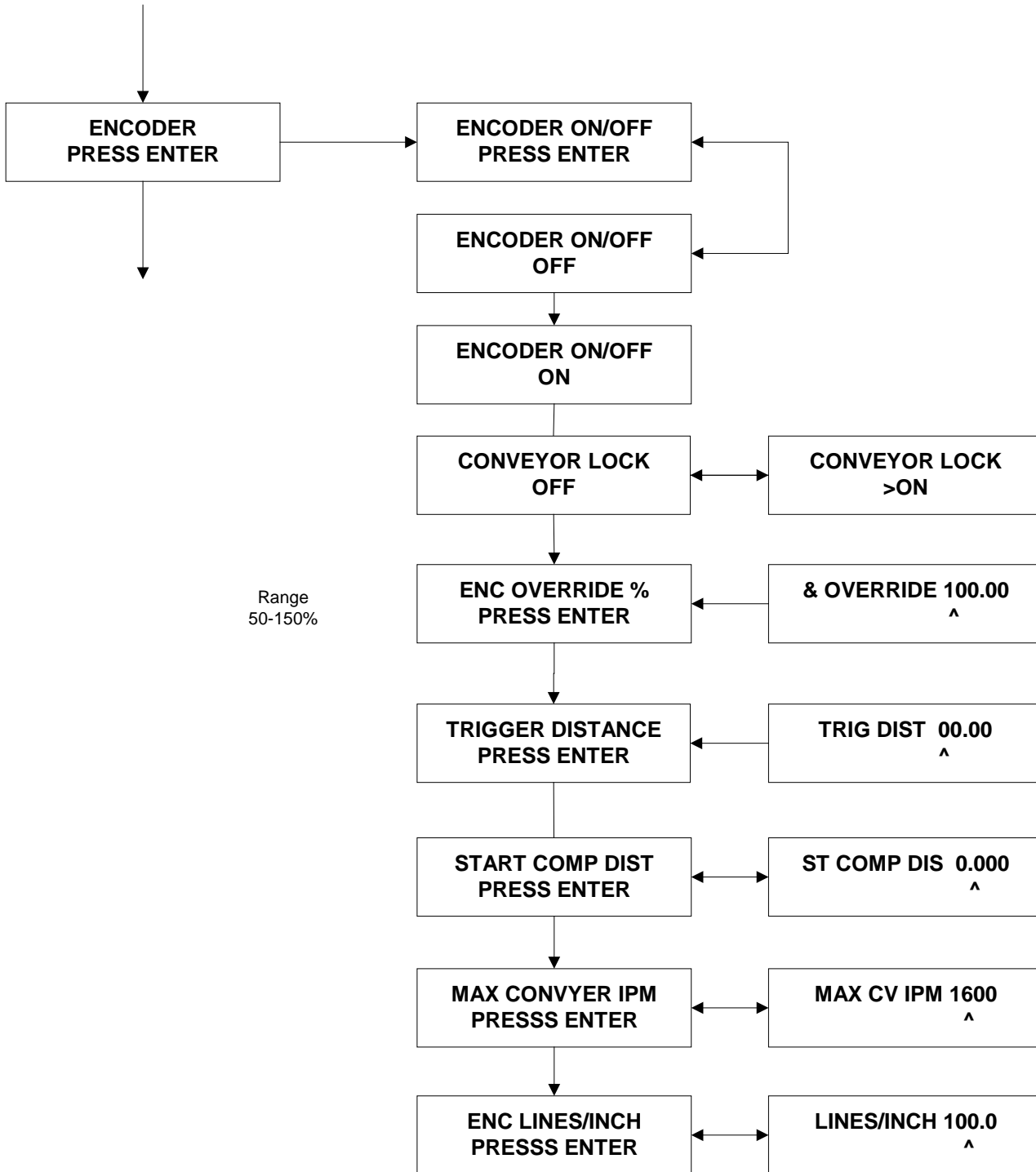

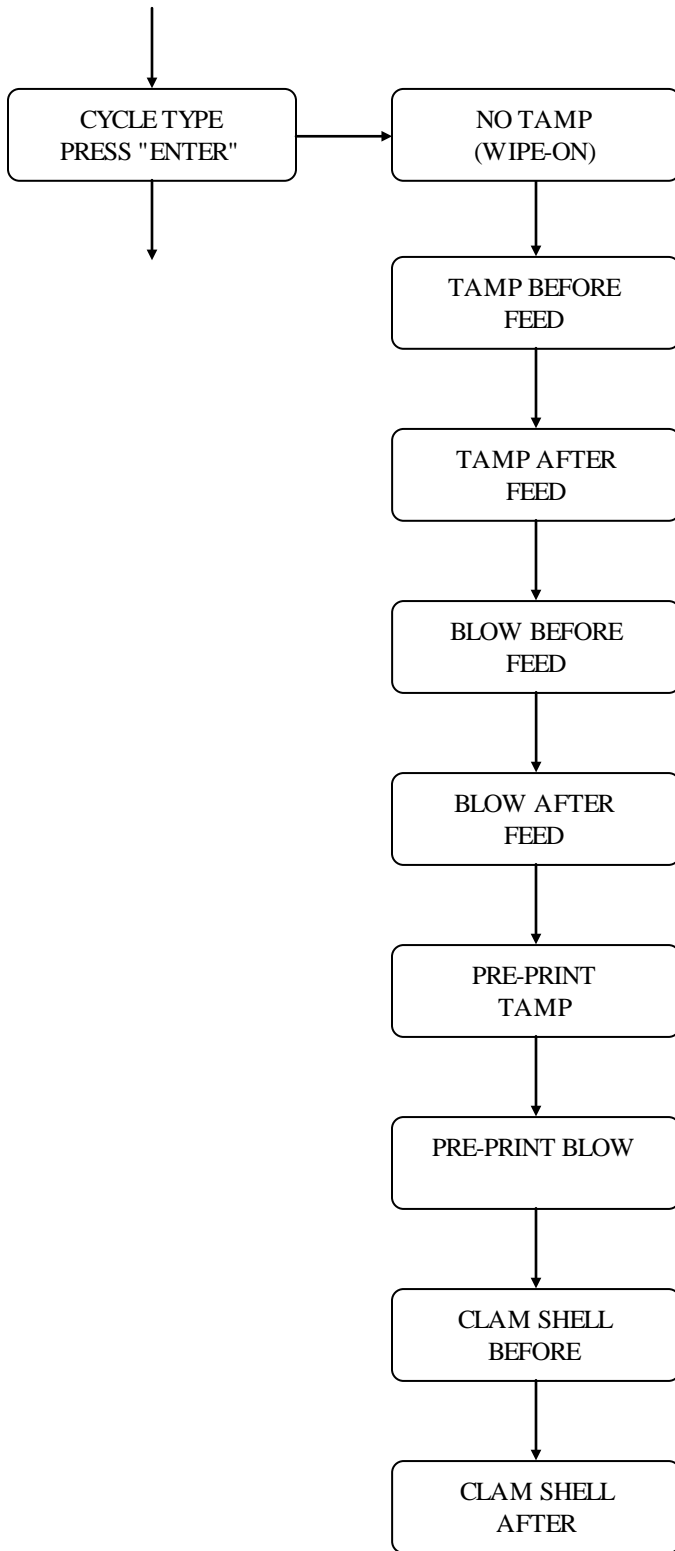

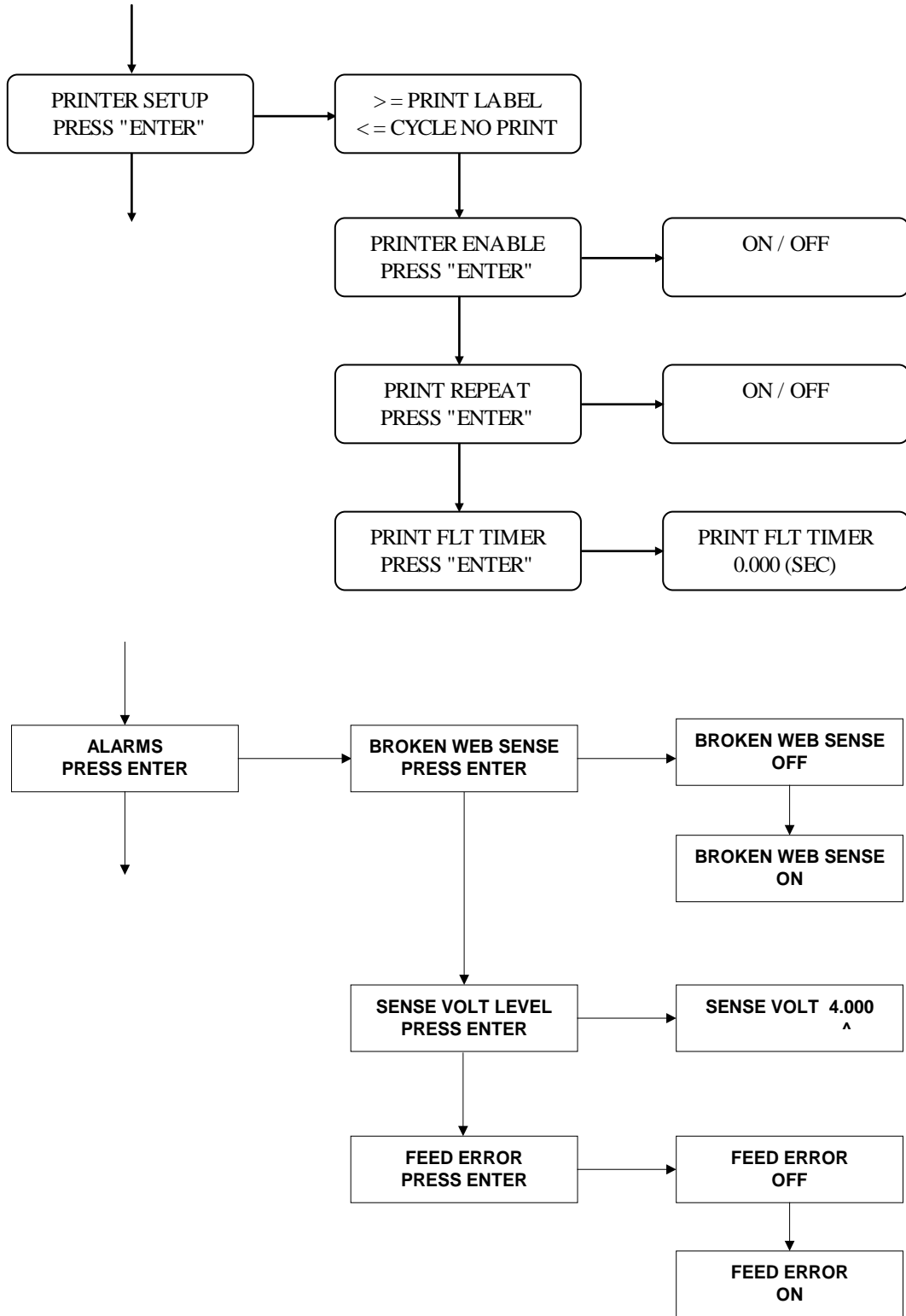

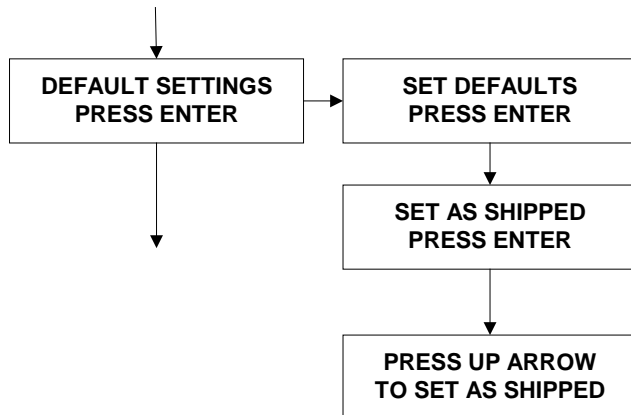
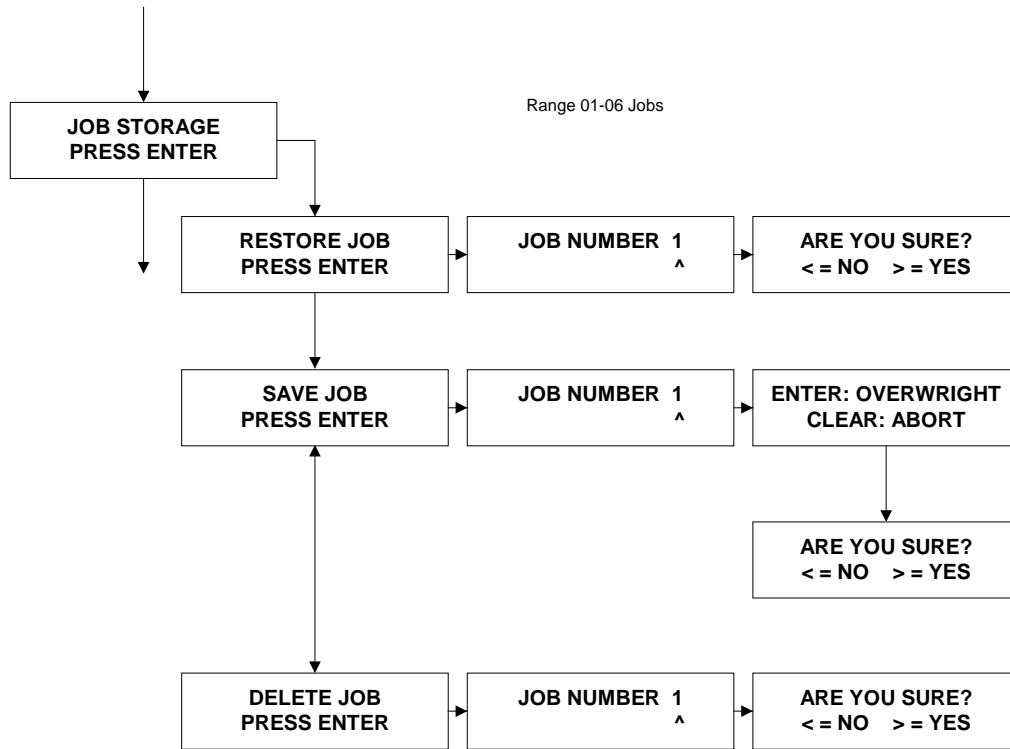

USER'S MANUAL

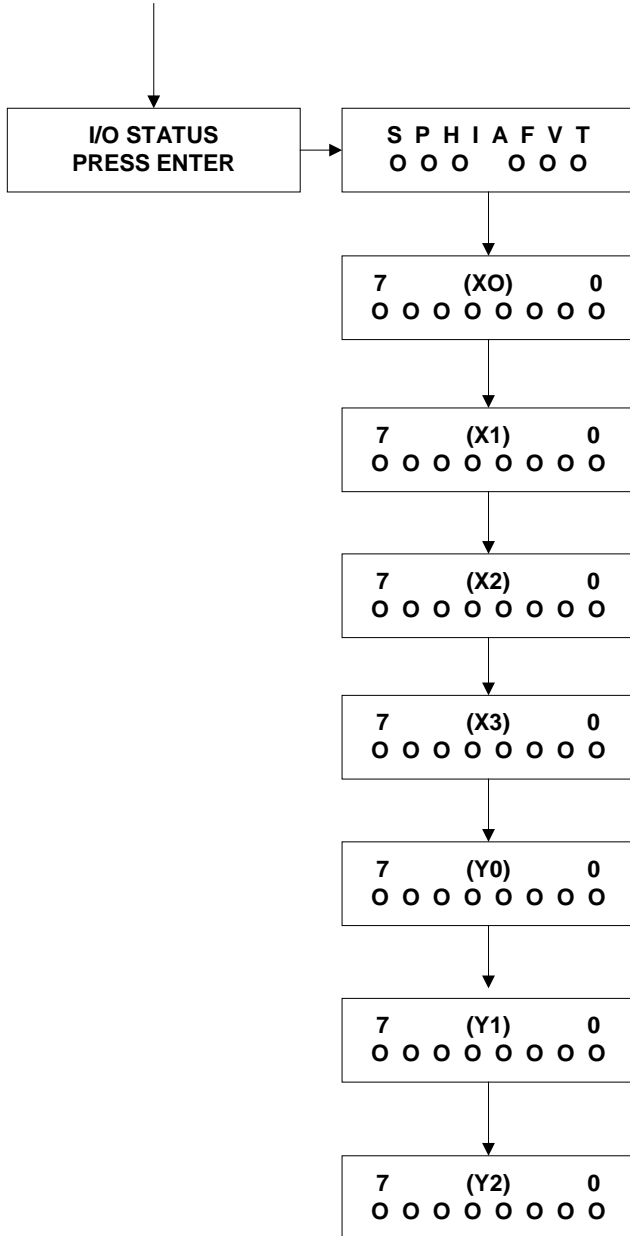

I/O Ports are numbered as follows  
7 6 5 4 3 2 1 0  
Ports are numbered from right to left.



## KEY DEFINITIONS

- **ASYNCHRONOUS OPERATION** – The term “ASYNCHRONOUS OPERATION” is used because the speed of the applicator motor (label speed) does not necessarily match the speed of the product conveyor. In other words their speeds are set independently of one another and have NO interrelation. An example of this is when the applicator is configured in the tamp mode.
- **SYNCHRONOUS OPERATION** – The term “SYNCHRONOUS OPERATION” is used because the speed of the applicator motor (label speed) is matched to the speed of the product conveyor. In order to accomplish this, an encoder is used to monitor the speed and distance the product conveyor travels. In order for this feature to function the “CONVEYOR LOCK” mode must be turned on. In synchronous operation, the applicator motor is ELECTRONICALLY GEARED to the product conveyor.
- **START COMPENSATION** – Start compensation compensates for the reaction time of the LabelMill control and start signal from the product switch. The purpose of start compensation is to maintain label placement on a product that is traveling at different speeds. An example of this is a conveyor that accelerates on start up and decelerates to a stop. At high speeds an uncompensated system would apply a label too late and the label would be placed too far back on the product. Linear interpolation is used to correct this problem. The start compensation corrects this error by adding an offset distance at LOW speeds, since it is not possible to apply any correction at high speed. **Note: Start compensation ONLY effects label placement on product.**
- **STOP COMPENSATION** – Stop compensation is used to correct the LabelMill application head ONLY. The reaction time of the LabelMill control and label sensor is corrected. The purpose of stop compensation is to maintain label placement at the peeler plate when the label web is traveling at different speeds. An example of this is when the applicator is synchronous feeding a label onto a product on a conveyor that accelerates on start up and decelerates to a stop. At high speeds, an uncompensated system label would stop past the peeler plate end. Linear interpolation is used to correct this problem. The stop compensation corrects this error by adding an offset distance at LOW label feed speeds, since it is not possible to apply any correction at high speed. **Note: Stop compensation ONLY effects label stop position relative to peeler plate and is normally ONLY used in synchronous feed with conveyor lock on.**
- **ELECTRONIC GEARING** – Electronic gearing is a function of the product encoder and the LabelMill control. This is used to match the speed of the applicator to the product conveyor. Electronic gearing is similar to mechanical gearing in that there is a gear ratio and the change of speed of one affects the speed of the other. This feature is part of the Synchronous feed mode. In order for this to operate properly, the correct number of lines per inch of product travel must be entered into the ENC LINES/INCH in menu #6.
- **ENCODER** – AN ENCODER is a device that is used to monitor the speed of an external device like a product conveyor. The reason this speed is monitored is to match the speed of the label applicator to the product speed. An encoder uses “LINES or COUNTS” per revolution in order to track speed and distance. Note that lines per revolution are also referred to as counts per revolution. These counts are feed into the LabelMill control to be processed for the different features that require this feed back.

- **ENCODER OVERRIDE** – This feature is used in conjunction with **ELECTRONIC GEARING**. This feature is used to fine-tune the ratio of the applicator to the product conveyor.
- **TRIGGER DIST** – **TRIGGER DISTANCE** is used in conjunction with the encoder feature. Trigger distance is similar to product delay in that it is used to electronically move the placement of the label on the product. When the encoder feature is used, the product delay feature is rendered inactive. Trigger distance will move the label placement in inches (00.00).
- **PRODUCT DELAY** is **NOT** used in conjunction with the encoder feature. Product delay is similar to trigger distance in that it is used to electronically move the placement of the label on the product. Product delay will move the label placement in time (00.000) seconds. Because the product delay feature utilizes time, the speed of the product **MUST** remain constant. A product traveling at a higher velocity will travel further in a given time, thus effecting the placement of the label.

## SETUP OF KEY FEATURES

- **START COMP DIST – START COMPENSATION DISTANCE**
  1. Set basic applicator up first, refer to quick setup
  2. Set up STOP COMP DIST, refer to STOP COMPENSATION DISTANCE setup
  3. Set ENCODER to “ON”.
  4. Set CONVEYOR LOCK to “ON” if in SYNCHRONOUS operation and “OFF” if in ASYNCHRONOUS operation.
  5. Set TRIGGER DIST to 00.00
  6. Set ENCODER LINES PER INCH (refer to ENC LINES set up)
  7. Start system and apply label at the fastest desired speed. (system should not exceed maximum rate of applicator if in SYNCHRONOUS operation)
  8. Move product switch or use TRIGGER DIST to register label to desired position. Keep trigger distance to a minimum for best results.
  9. Change speed of system and operate it at the lowest speed desired.
  10. Measure the offset in label placement.
  11. Enter the measured offset into the START COMP DIST.
  12. Operate system at the same low speed again and check label offset.
  13. Make the necessary adjustments to the START COMP DIST.
  14. Test again, repeat if necessary until label is in proper registration.
  15. System should now hold registration throughout speed range.
  16. Turn back on any options that may have been disabled for setup of this particular feature.

Note there will be some label drift if speed range is too great or top speed is out of range of applicator. There is also the normal placement tolerance that will effect the accuracy of the system.

- **STOP COMP DIST – LABEL STOP COMPENSATION DISTANCE**
  1. Set basic applicator up first, refer to quick setup.
  2. Set MISSING LABEL to “OFF”.
  3. Set encoder to “OFF” or if already interfaced to conveyor, start and run system together for testing.
  4. Set START COMP DIST. To “OFF”.
  5. Set LABEL AUTO POSN to “ON”. (label auto position)
  6. Set STOP COMP DIST to 0.000
  7. Operate applicator at maximum speed. Limit top speed to no more than required.
  8. Manually move the label sensor to adjust the label stop position. The proper stop position will be with the leading edge of the label stopping flush with the tip of the peeler plate. The label stop position can also be electronically adjusted using the LABEL STOP POSITION. If this option is used the distance must be kept to a minimum. Adjusting the stop position using the LABEL STOP POSITION is NOT recommended when utilizing the STOP COMP DIST feature.
  9. Operate the applicator at the lowest desired speed.
  10. Measure the offset in label stop position. Enter the measured offset into the STOP COMP DIST.
  11. Operate system at the same low speed again and check label offset.
  12. Make the necessary adjustments to the STOP COMP DIST.
  13. Test again, repeat if necessary until label is in proper registration.
  14. Applicator should now hold registration throughout speed range.
  15. Turn back on any options that may have been disabled for setup of this particular feature.

Note: There will be some label drift if speed range is too great or if at top speed the label is out of control. There is also the normal stop tolerance that will effect the accuracy of the applicator.

- LABEL STOP POSITION

LABEL STOP POSITION is used to electronically move the stop position of the label on the applicator ONLY. The setup below describes how to use the LABEL STOP POSITION in ASYNCHRONOUS operation ONLY. For SYNCHRONOUS setup operation, refer to STOP COMP DIST section.

1. Set basic applicator up first, refer to quick setup.
2. Set MISSING LABEL to "OFF".
3. Set CONVEYOR LOCK "OFF".
4. Set LABEL AUTO POSN to "OFF". (label auto position)
5. Set STOP COMP DIST to 0.000
6. Operate applicator at desired label speed.
7. Manually move the label sensor to adjust the label stop position or the label stop position can also be electronically adjusted using the LABEL STOP POSITION. The proper stop position will be with the leading edge of the label stopping flush with the tip of the peeler plate. If this option is used the distance must be kept to a minimum. Adjusting the stop position using the LABEL STOP POSITION is NOT recommended when utilizing the STOP COMP DIST feature.
8. Operate the applicator again at the same speed.
9. Measure the offset in label stop position. Enter the measured offset into the LABEL STOP POSITION.
10. Operate system at the same speed again and check label offset.
11. Make the necessary adjustments to the LABEL STOP POSITION.
12. Test again, repeat if necessary until label is in proper registration to the peeler plate tip.
13. Turn back on any options that may have been disabled for setup of this particular feature.

Note: The LABEL STOP POSITION distance CAN NOT be greater than half the length of the label.

- MISSING LABEL COMP – MISSING LABEL COMPENSATION

Missing Label Compensation is used to advance the label liner to compensate for a label that is "missing". This will allow the applicator not to skip a label application onto the product. This feature will not work if the application rate is too high & has limited benefits when in synchronous operation. Because of the variety of label sizes and products, testing will be required to determine if this feature is beneficial to your particular application.

1. Set basic applicator up first, refer to quick setup.
2. Ensure that applicator is operating properly before starting this procedure.
3. Set MISSING LABEL to "ON".
4. Set MISSING LABEL COMP "ON"
5. Set CONVEYOR LOCK "OFF".
6. Set LABEL AUTO POSN to "ON" **if already SETUP**, otherwise set to "OFF"
7. Operate applicator at desired label speed ensuring that the label is stopping in the proper position. Refer to LABEL STOP POSN #7.
8. Count the number of labels from the label sensor to the tip of the peeler plate.
9. Enter this number in the "LABEL TO PEELR"
10. Remove a label from the web before the label sensor. (Not between the sensor and the peeler plate.)
11. Operate the applicator several times until the missing label is at the peeler plate.
12. The applicator should now double feed a label in the next cycle.
13. If the applicator double feeds too soon, subtract one from the LABELS TO PEELR count.
14. If the applicator double feeds too late, add one to the LABELS TO PEELR count.
15. Remove another label and operate system at the same speed again.
16. Test again, repeat if necessary until the system operates properly.
17. Turn back on any options that may have been disabled for setup of this particular feature.

- CALCULATING ENCODER LINES PER INCH (gearing)

There are two basic concepts utilized to interface the product ENCODER to the LabelMill control. One method utilizes a wheel mounted directly to an encoder. This wheel rests on the belt surface and rotates when the belt moves. The second method is to mechanically slave the encoder to the conveyor utilizing belts or a chain etc. Note that lines per revolution are also referred to as counts per revolution. The following is only a small sample of the many ways there is to couple an encoder to a product conveyor.

#### WHEEL-MOUNTED

1. Check encoder to determine the number of lines per revolution.
2. Measure diameter of contact wheel.
3. Multiply diameter of wheel by Pi, this will give circumference.
4. Divide encoder lines per revolution by circumference, this will net lines per inch.
5. Enter this number into menu "ENC LINES/INCH", note that this number needs to be between 25 & 500.

#### EXAMPLE

1. Encoder lines per revolution "1000".
2. Contact wheel diameter "6.00".
3.  $6.00 \times 3.14 = 18.84$ "
4.  $1000/18.84 = 53.1$  (rounding number to the 10<sup>th</sup>)
5. Enter 53.1 into "ENC LINES/INCH"

#### DIRECT DRIVE

1. Check encoder to determine the number of lines per revolution.
2. Determine the gear ratio of the encoder to the conveyor
3. Measure diameter of conveyor drive wheel.
4. Multiply diameter of wheel by Pi, this will give circumference.
5. Divide encoder lines per revolution by circumference, this will net lines per inch of wheel.
6. Multiply this number by the gear ratio, this will net lines per inch
7. Enter this number into menu "ENC LINES/INCH", note that this number needs to be between 25 & 500.

#### EXAMPLE

1. Encoder lines per revolution "1000".
2. Gear ratio is 2 to 1.
3. Conveyor drive wheel diameter "6.00".
4.  $6.00 \times 3.14 = 18.84$ "
5.  $1000/18.84 = 53.079$
6.  $53.079 \times 2 = 106.2$  (rounding number to the 10<sup>th</sup>)
7. Enter 106.2 into "ENC LINES/INCH"

- TRIGGER DIST – TRIGGER DISTANCE

TRIGGER DISTANCE is used in conjunction with the encoder feature. Trigger distance is similar to product delay in that it is used to electronically move the placement of the label on the product. When the encoder feature is used, the product delay feature is rendered inactive. Trigger distance will move the label placement in inches (00.00).

1. Set basic applicator up first, refer to quick setup
2. Ensure that the applicator is operating properly before starting this procedure.
3. This feature requires the use of an encoder. The appropriate encoder features should be setup prior to this feature.
4. Set ENCODER to “ON”.
5. Set CONVEYOR LOCK to “ON” if in SYNCHRONOUS operation and “OFF” if in ASYNCHRONOUS operation.
6. Set TRIGGER DIST to 00.00
7. Start system and apply label at the desired speed.
8. Check the placement of the label on the product.
9. Measure the OFFSET of the label placement. Note: A label CAN NOT be advanced on the product ONLY moved “back” since the applicator can only delay the product signal.
10. Apply the measured offset to the TRIGGER DISTANCE or if too great it may be necessary to physically move the product switch. Keep trigger distances to a minimum for best results.
11. Operate system again and measure offset.
12. Enter the measured offset, IF ANY, into the TRIGGER DISTANCE.
13. Test again, repeat if necessary until label is in proper registration.
14. Turn back on any options that may have been disabled for setup of this particular feature.

- PRODUCT DELAY

PRODUCT DELAY is NOT used in conjunction with the encoder feature. Product delay is similar to trigger distance in that it is used to electronically move the placement of the label on the product. Product delay will move the label placement in time (00.000). Because the product delay feature utilizes time, the speed of the product MUST be constant and consistent.

1. Set basic applicator up first, refer to quick setup
2. Ensure that applicator is operating properly before starting this procedure.
3. This feature requires the use of an encoder. The appropriate encoder features should be setup prior to this feature.
4. Set ENCODER to “OFF”.
5. Set CONVEYOR LOCK to “OFF” if in ASYNCHRONOUS operation.
6. If in SYNCHRONOUS operation PRODUCT DELAY WILL NOT WORK
7. Set Product delay to 00.000
8. Start system and apply label at the desired speed.
9. Check the placement of the label on the product.
10. Measure the OFFSET of the label placement. Note: A label CAN NOT be advanced on the product ONLY moved “back” since the applicator can only delay the product signal.
11. Apply a small delay to the product delay or if too great, it may be necessary to physically move the product switch. Keep product delays to a minimum for best results.
12. Operate system again and measure offset.
13. Apply a small delay to the product delay or reduce if too much.
14. Test again, repeat if necessary until label is in proper registration.
15. Turn back on any options that may have been disabled for setup of this particular feature.

- **BROKEN WEB**

BROKEN WEB feature is used to detect the breakage of the label web. Note this feature will not work with clear labels. The label sensor detects the broken web by comparing the difference in the opacity of the label liner to NO label liner. The opacity of the label and liner are displayed in volts.

1. Set basic applicator up first, refer to quick setup.
2. Ensure that the applicator is operating properly before starting this procedure.
3. While in the normal run display, push the down arrow twice.
4. The display should now show GAP VOLT.
5. Position the label in the label sensor until the maximum voltage is displayed. (LABEL GAP)
6. Record the label gap voltage.
7. Remove the label and liner from the label sensor.
8. With the label & liner removed record the BROKEN WEB GAP VOLTAGE
9. The BROKEN WEB voltage should be at least .900 volts higher than the LABEL gap voltage.
10. If there is not .900 volts difference this option may not work with the selected labels.
11. Subtract .700 from the BROKEN WEB voltage.
12. This new Calculated Broken web voltage is the reference voltage that will be entered into the control.
13. Enter programming and advance to menu ALARMS.
14. Turn BROKEN WEB "ON"
15. SENSE VOLT LVL enter calculated broken web voltage.
16. The control is now set to detect a broken web and will output an alarm if a broken web is detected or if you remove the label stock.
17. Turn back on any options that may have been disabled for setup of this particular feature.

- **FEED ERROR**

FEED ERROR is used in the tamp mode (asynchronous mode). This feature detects the presents of a label on the tamp pad by utilizing a fiber-optic sensor embedded into the tamp pad. The control "looks" for the tamp pad to be clear before it feeds a label and "blocked" after it feeds the label. The system will display a "FEED ERROR" fault if the label does not make it onto the tamp pad properly, does not make it onto the product and stays on the tamp pad or gets "stuck" to tamp pad.

1. Set basic applicator up first, refer to quick setup.
2. Ensure that the applicator is operating properly before starting this procedure.
3. With the label on the tamp pad, check to see if the red light on the label present detector is on.
4. If the light is NOT on, the sensor or the label feed may require adjustment.
5. Set FEED ERROR to "ON".
6. Cycle system one time.
7. Verify proper operation.
8. Test again, repeat if necessary until the system operates properly.
9. Turn back on any options that may have been disabled for setup of this particular feature.

- MANUAL-SET GAP

MANUAL-SET GAP is used to manually set the label sensor to the label stock that is webbed in the applicator. This step is automatically taken care of in the AUTO SETUP mode covered in QUICK SETUP chapter. If the values the applicator calculated are in question, the following will allow manual calibration of the label.

1. Go to MANUAL –SET GAP press “enter”
2. Move label in label sensor gap until the LOWEST value is displayed – press “enter” (center of label)
3. Move label in label sensor gap until the HIGHEST value is displayed – press “enter” (gap between labels)
4. GAP THRESHOLD is now displayed. This is the difference between the highest value and the lowest value.
5. GAP THRESHOLD can be manually over ridden for difficult labels.

- LABEL LENGTH and LABL GAP LENGTH

LABEL LENGTH is automatically calculated and entered when utilizing auto set up. If the length of the label is known and does not match the displayed value, this can be manually entered.

- LABL GAP LENGTH – LABEL GAP LENGTH

LABEL GAP LENGTH is the space between two labels. LABEL GAP LENGTH is automatically calculated and entered when utilizing auto set up. If the gap length of the label web is know and does not match the displayed value this can be manually entered. This distance is USUALLY .125”.



## QUICK START GENERAL SETUP

1. Inspect applicator system and verify all cables are installed properly.
2. Web system with labels.
3. Turn power switch on.
4. Press "PROG"
5. Press UP arrow
6. "ENTER" AUTO SETUP
7. System will feed out 2 to 10 labels to calibrate system.
8. If calibration fails, check label stock, web routing, cable connections and applicator condition.
9. Attempt "AUTO SETUP" again
10. If AUTO SETUP fails again, manual set up will be required.
11. Once auto set up is complete, cycle system twice by pressing the "START key.
12. Observe label speed and change if required.
13. Manually move the label sensor so the label stops flush with the peeler plate tip.
14. System is now ready for set up of advanced features and options.

## MANUAL SET UP

1. Inspect applicator system and verify all cables are installed properly.
2. Web system with labels.
3. Turn power switch on.
4. Press "PROG"
5. Down arrow to "DEFAULT SETTINGS" press ENTER
6. Press UP arrow to set defaults
7. Perform "MANUAL-SET GAP"
8. Program in label length and Label gap length.
9. Once manual set up is complete cycle system twice by pressing the "START key.
10. Observe label speed and change if required.
11. Manually move the label sensor so the label stops flush with the peeler plate tip.
12. System is now ready for set up of advanced features and options.

## HOW TO SET UP AN ASYNCHRONOUS APPLICATION

- "TAMP" WITHOUT AN ENCODER

Determine the following and select it in the software

1. Type of application mode. (Tamp)
2. Tamp before or after feed (before feed is standard)
3. Enter a value in the tamp duration (start with 00.20)
4. Set head up limit switch, normally open is standard
5. Use the product delay to "MOVE" the label on the product

The asynchronous application mode is used to apply labels to products that are either stationary or moving at a constant speed when the label application is to take place.

- "BLOW" WITHOUT AN ENCODER

Determine the following and select it in the software

1. Type of application mode. (Blow)
2. Blow before or after feed (before feed is standard)
3. Enter a value in the tamp duration (start with 00.10)
4. Set head up limit switch to NO TAMP SWITCH
5. Use the product delay to "MOVE" the label on the product

The asynchronous application mode is used to apply labels to products that are either stationary or moving at a constant speed when the label application is to take place.

- TAMP OR BLOW WITH A ENCODER

Determine the following and select it in the software

1. Type of application mode. (Tamp, or Blow) (refer to above)
2. Tamp or blow before or after feed (before feed is standard)
3. Enter a value in the tamp duration (start with 00.20)
4. Turn encoder ON
5. Conveyor "LOCK" should be OFF
6. Encoder OVERRIDE is used to fine tune the GEARING RATIO between applicator and conveyor
7. Trigger distance is used to "MOVE" label on product (product delay is disabled)
8. Enter a Start Comp value. START Comp is used to compensate for label drift when speed of conveyor changes. To calculate this refer to the section on "Start Compensation"
9. ENC LINES/INCH enter the proper "lines per inch" to match encoder output to conveyor speed. To calculate "lines per inch", refer to the section on Gearing.

## HOW TO APPLY MULTIPLE LABELS TO A SINGLE PRODUCT

- **WHEN UTILIZING A ENCODER**

This section will explain how to apply more than one label to a single product with a single start signal. TRIGGER DISTANCE will move the label placement in inches (00.00) for the **FIRST LABEL**. MULTIPLE FEED will allow you to select how many labels to be applied. Note that when the start signal “goes false” this feature is reset. When the encoder feature is used, the product delay feature is rendered inactive.

1. Set basic applicator up first, refer to quick setup
2. Ensure that the applicator is operating properly before starting this procedure.
3. This feature requires the use of an encoder. The appropriate encoder features should be setup prior to this feature.
4. Set ENCODER to “ON”.
5. Set CONVEYOR LOCK to “ON” if in SYNCHRONOUS operation and “OFF” if in ASYNCHRONOUS operation.
6. Set TRIGGER DIST to 00.00 (refer to TRIGGER DISTANCE setup)
7. Start system and apply label at the desired speed.
8. Check the placement of the label on the product.
9. Measure the OFFSET of the label placement. Note: A label CAN NOT be advanced on the product ONLY moved “back” since the applicator can only delay the product signal.
10. Apply the measured offset to the TRIGGER DISTANCE or if too great it may be necessary to physically move the product switch. Keep trigger distances to a minimum for best results.
11. Operate system again and measure offset.
12. Enter the measured offset, IF ANY, into the TRIGGER DISTANCE.
13. Test again, repeat if necessary until label is in proper registration.
14. Go to MULTIPLE FEED in menu #1 and set the number of labels to be applied to the product.
15. Set the Distance between each label by measuring from the front of the product to where you would like the label to be applied.
16. Set this distance in the 0 to 2 and repeat this for each label to be applied. 0 to 3, 0 to 4, etc.
17. Test the placement of the label and adjust as necessary. Note: The measurements entered are reference only and may not correspond exactly to the actual label offset measurements.
18. Note: TRAILING EDGE TRIGGER will NOT work with this feature!
19. Note: Product speed fluctuations can effect label placement.
20. Turn back on any options that may have been disabled for setup of this particular feature.

- **WHEN NOT UTILIZING A ENCODER**

Product delay is similar to trigger distance in that it is used to electronically move the placement of the **FIRST** label on the product. Product delay will move the label placement in time (00.000). Because the product delay feature utilizes time, the speed of the product **MUST** be constant and consistent. This section will explain how to apply more than one label to a single product with a single start signal. **MULTIPLE FEED** will allow you to select how many labels to be applied. Note that when the start signal “goes false” this feature is reset.

1. Set basic applicator up first, refer to quick setup
2. Ensure that applicator is operating properly before starting this procedure.
3. This feature requires the use of an encoder. The appropriate encoder features should be setup prior to this feature.
4. Set ENCODER to “OFF”.
5. Set CONVEYOR LOCK to “OFF” if in ASYNCHRONOUS operation.
6. If in SYNCHRONOUS operation PRODUCT DELAY WILL NOT WORK
7. Set Product delay to 00.000
8. Start system and apply label at the desired speed.
9. Check the placement of the label on the product.
10. Measure the OFFSET of the label placement. Note: A label **CAN NOT** be advanced on the product **ONLY** moved “back” since the applicator can only delay the product signal.
11. Apply a small delay to the product delay or if too great, it may be necessary to physically move the product switch. Keep product delays to a minimum for best results.
12. Operate system again and measure offset.
13. Apply a small delay to the product delay or reduce if too much.
14. Test again, repeat if necessary until label is in proper registration.
15. Go to **MULTIPLE FEED** in menu #1 and set the number of labels to be applied to the product.
16. Set the Distance between each label entering a time (0.000) into “**INTERVAL DELAY**”
17. Test the placement of the labels and adjust as necessary. Note: The spacing between each label will be equal. With this feature the space between labels **can not** be set individually.
18. Note: **TRAILING EDGE TRIGGER** will NOT work with this feature!
19. Note: Product speed fluctuations can effect label placement.
20. Turn back on any options that may have been disabled for setup of this particular feature.

## DESCRIPTION OF I/O

All user inputs and outputs are “**SINKING**” type, except for the special isolated ground I/O. Example in order for a status light to illuminate for “Run Status Ok” the light should be wired between pins #1 & #8 on the “**Light Bar/Aux.**” Connector. (Note: some outputs can be wired to sourcing type outputs)

Status display legend.

INPUTS				OUTPUTS			
S	P	H		A	F	V	T
SMART TAMP	PRODUCT SENSOR	TAMP SENSOR		AIR ASSIST SOL	FLAG SOL	VACUUM SOL	TAMP SOL

When using the I/O status ports to verify if the inputs and outputs are on or off, the ports are numbered as from right to left follows are as shown below: In this sample port Y2:0 , Y2:1 , Y2:3 , Y2:5 ,and Y2:7 are on.

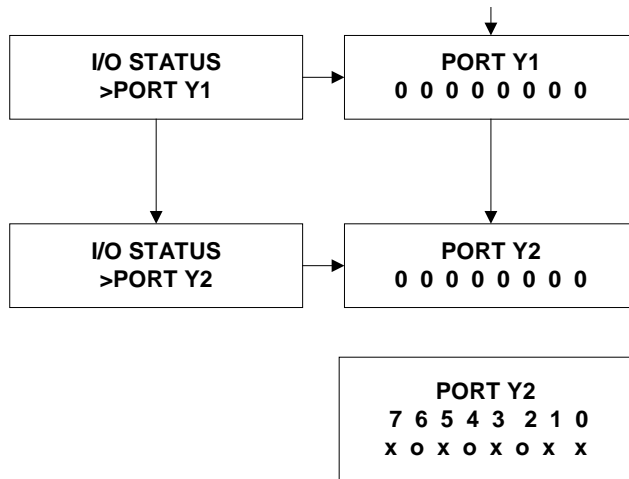

REMOTE TRIGGER CONNECTOR (PRODUCT SWITCH) 4 pin Amp	P1-A PIN #	ADDRESS
+24 VDC	1	
TRIGGER INPUT	2	X0,0
24 COM	3	
	4	

REMOTE TRIGGER CONNECTOR (Pre-Print PRODUCT SWITCH) 4 pin Amp	P1-B PIN #	ADDRESS
+24 VDC	1	
TRIGGER INPUT	2	X0,1
24 COM	3	
	4	

TAMP SOLENOIDS CONNECTOR 9 pin Amp	P2 PIN #	INPUT/ OUTPUT	ADDRESS
TAMP SOL	1	O	Y0,3
VACUUM SOL	2	O	Y0,2
TAMP HEAD UP SW IN	3	I	X0,2
24 COM	4		
+24 VDC	5		
FLAG SOL	6	O	Y0,1
AIR ASSIST SOL	7	O	Y0,0
SMART TAMP IN	8	I	X0,3
AUX OUT 7	9	O	Y0,4

LABEL SENSOR CONNECTOR 8 pin Amp	P3 PIN #	Address
SENSOR COLLECTOR (GREEN)	1	Green
DIODE CATHODE (BLACK)	2	Black
DIODE ANODE (RED)	3	Red
SENSOR EMITTER (WHITE)	4	White
SHIELD	5	
+24VDC	6	
24 COM	7	
Clear label detector (input)	8	X0,4

PRINT AND APPLY INTERFACE	P4 PIN #	I/O	ADDRESS
PAPER END	1	INPUT	X0,5
PRINTER GROUND	2		
RIBBON END	3	INPUT	X0,6
PRINTER ERROR	4	INPUT	X0,7
PRINT START	5	OUTPUT	Y0,5
PRINT END	6	INPUT	X1,0
REPRINT	7	OUTPUT	Y0,6
N.C.	8		
ONLINE (SATO only)	9	INPUT	X1,7
RIBBON NEAR END	10	INPUT	X1,1
ONLINE (ZEBRA only)	11	INPUT	X1,2
	12		
+5vdc from printer	13		
	14		
SHIELD			

LIGHT BAR/AUXILIARY CONNECTOR DB-15 FEMALE	P5-A PIN #	INPUT/ OUTPUT	ADDRESS	
+24VDC	1			
+24VDC	2			
24 COM	3			
24 COM	4			
LOW LABEL IN	5	I	X1,3	
ERROR (Red light)	6	O	Y0,7	
LOW LABEL (Yellow light)	7	O	Y1,0	
RUN STATUS OK (Green Light)	8	O	Y1,1	
TAMP SYNC OUT	9	O	Y1,2	
INHIBIT IN	10	I	X1,4	
LABEL FEED ERROR IN	11	I	X1,5	
Repeat Last label In	12	I	X1,6	
Servo Tamp Fault Input	13	I	X3,4	"Head Down Fault"
Applicator in Cycle Output (Applicator Busy)	14	O	Y1,3	Paralleled with Y2,4
AUX OUT 6	15	O	Y1,4	

LIGHT BAR/AUXILIARY CONNECTOR DB-15 FEMALE	P5-B PIN #	INPUT/ OUTPUT	ADDRESS	
+24VDC	1			
+24VDC	2			
24 COM	3			
24 COM	4			
LOW LABEL IN	5	I	X1,3	
ERROR (Red light)	6	O	Y0,7	
LOW LABEL (Yellow light)	7	O	Y1,0	
RUN STATUS OK (Green Light)	8	O	Y1,1	
TAMP SYNC OUT	9	O	Y1,2	
INHIBIT IN	10	I	X1,4	
LABEL FEED ERROR IN	11	I	X1,5	
Repeat Last label In	12	I	X1,6	
Servo Tamp Fault Input	13	I	X3,4	"Head Down Fault"
Applicator in Cycle Output (Applicator Busy)	14	O	Y1,3	Paralleled with Y2,4
AUX OUT 6	15	O	Y1,4	

LIGHT BAR/AUXILIARY CONNECTOR DB-15 FEMALE	P5-C PIN #	INPUT/ OUTPUT	ADDRESS	
+24VDC	1			
+24VDC	2			
24 COM	3			
24 COM	4			
LOW LABEL IN	5	I	X1,3	
ERROR (Red light)	6	O	Y0,7	
LOW LABEL (Yellow light)	7	O	Y1,0	
RUN STATUS OK (Green Light)	8	O	Y1,1	
TAMP SYNC OUT	9	O	Y1,2	
INHIBIT IN	10	I	X1,4	
LABEL FEED ERROR IN	11	I	X1,5	
Repeat Last label In	12	I	X1,6	
Servo Tamp Fault Input	13	I	X3,4	"Head Down Fault"
Applicator in Cycle Output (Applicator Busy)	14	O	Y1,3	Paralleled with Y2,4
AUX OUT 6	15	O	Y1,4	

USER'S MANUAL

AUX I/O DB25 Female CONNECTOR #J1	P6-A PIN #	INPUT/ OUTPUT	ADDRESS	
+24VDC	1			
+24VDC	2			
24V COM	3			
24V COM	4			
Input Common	5			Pin 5 and 1 tied for sinking inputs, pin 5 to pin 3 for sourcing
<b>Note: This must be tied to pin 1 or 3!</b>				
2 <sup>nd</sup> Tamp Output (Stand alone CW module)	6	O	Y1,7	
2 <sup>nd</sup> Tamp Head Up Sw itch (CW module)	7	I	X2,2	
2 <sup>nd</sup> Tamp Trigger in (photo eye) (CW module)	8	I	X2,3	
E-Stop PB Input	9			pin 9 and 10 tied for E-stop
E-Stop Reset PB input	10			
E-Stop PB's Common	11			
1520 TAKE-UP MOTOR	12	O	Y2,0	
AUX IN 10	13	I	X2,4	
AUX IN 8	14	I	X3,6	
AUX IN 1	15	I	X2,6	
AUX IN 2	16	I	X2,7	
AUX IN 3	17	I	X3,0	
AUX IN 4	18	I	X3,1	
AUX IN 5	19	I	X3,2	
AUX IN 6	20	I	X3,3	
AUX OUT 1	21	O	Y2,1	
AUX OUT 2	22	O	Y2,2	
AUX OUT 3	23	O	Y2,3	
Applicator in cycle output (Applicator Busy)	24	O	Y2,4	Paralleled w ith Y1,3
Batch Done	25	O	Y1,6	

AUX I/O DB25 Male CONNECTOR #J2	P6-B PIN #	INPUT/ OUTPUT	ADDRESS	
AUX IN 10	1	I	X2,4	
1520 TAKE-UP MOTOR	2	O	Y2,0	
E-Stop PB's Common	3			24V RELAY CIRCUIT
E-Stop Reset PB input	4			24V RELAY CIRCUIT
E-Stop PB Input	5			24V RELAY CIRCUIT
2 <sup>nd</sup> Tamp Trigger in (photo eye) (CW module)	6	I	X2,3	
2 <sup>nd</sup> Tamp Head Up Sw itch (CW module)	7	I	X2,2	
2 <sup>nd</sup> Tamp Output (Stand alone CW module)	8	O	Y1,7	
AUX OUT 5	9	O	Y2,5	
24V COM	10			
24V COM	11			
+24VDC	12			
+24VDC	13			
Batch Done	14	O	Y1,6	
Applicator in cycle output (Applicator Busy)	15	O	Y2,4	Paralleled w ith Y1,3
AUX OUT 3	16	O	Y2,3	
AUX OUT 2	17	O	Y2,2	
AUX OUT 1	18	O	Y2,1	
AUX IN 7	19	I	X3,5	
AUX IN 5	20	I	X3,2	
AUX IN 4	21	I	X3,1	
AUX IN 3	22	I	X3,0	
AUX IN 2	23	I	X2,7	
AUX IN 1	24	I	X2,6	
AUX IN 8	25	I	X3,6	

NOTE: Input X3,7 IS USED INTERNALLY FOR MCR STATUS



**E-STOP Wiring (DB-25 FEMALE / J1 ONLY)**

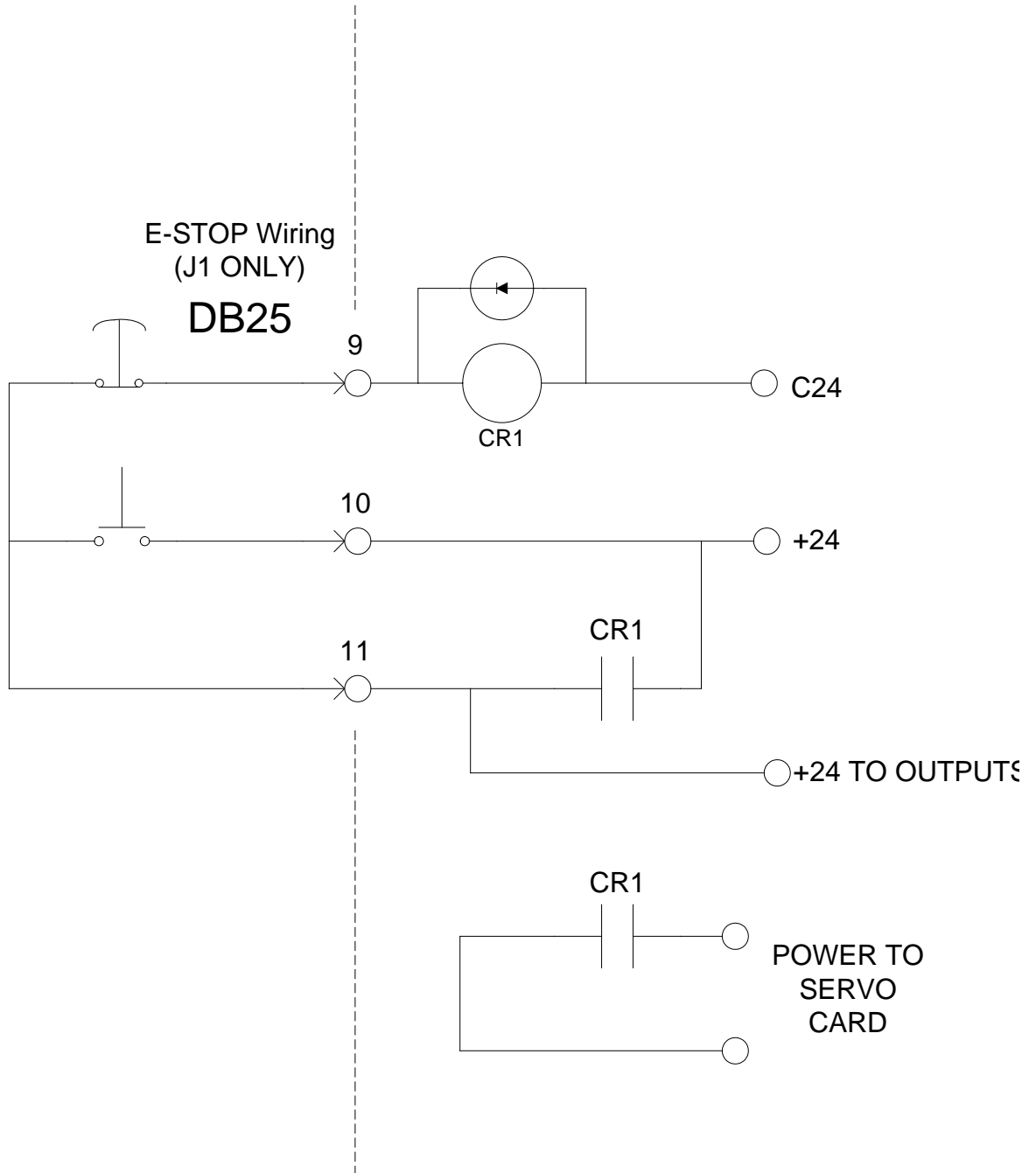

Display COMM. 8 Pin RJ	P7-J3 PIN #	
<b>422 Touch Screen</b>		
RX+	1	
RX-	2	
Touch Sense (GND)	3	
Fault line O.C.	4	
GND	5	
GND	6	
TX+	7	
TX-	8	

Display COMM. 6 Pin RJ	P7-J4 PIN #		
<b>HLI-100</b>			
<b>232 Hand Held</b>			
TX	1		
RX	2		
GND	3		
GND	4		
+24	5		
+24	6		

COMM. 1 RS-232 DB9 Female	P8 PIN #		
NC	1		
RS232 XMIT	2		
RS232 RCV	3		
NC	4		
GND	5		
NC	6		
NC	7		
NC	8		
SHIELD	9		

COMM. 2 RS-232 DB9 Female	P9 PIN #	INPUT/ OUTPUT	ADDRESS
<b>Serial Plus Port</b>			
+24	1		
RS232 XMIT	2		
RS232 RCV	3		
24C	4		
GND	5		
Aux Out	6	O	Y1,5
Aux In	7	I	X2,1
NC	8		
SHIELD	9		

CONVEYOR ENCODER DB9 Male	P10 PIN #
2ENC A+	1
2ENC A-	2
2 ENC B+	3
2 ENC B-	4
+5 vdc	5
GND	6
Shield	7
NC	8
NC	9

# LM3560 SETUP

## DIP SWITCH COMMUNICATIONS ADDRESS

HOW TO SET LABELER COMMUNICATIONS ADDRESS FOR A 3560

WHEN USING MULTIPLE LABELERS WITH ONE TS204 TOUCHSCREEN, EACH LABELER MUST BE SET UP WITH A UNIQUE COMMUNICATIONS ADDRESS.

UP TO FOUR LABELERS CAN BE USED WITH ONE TS204

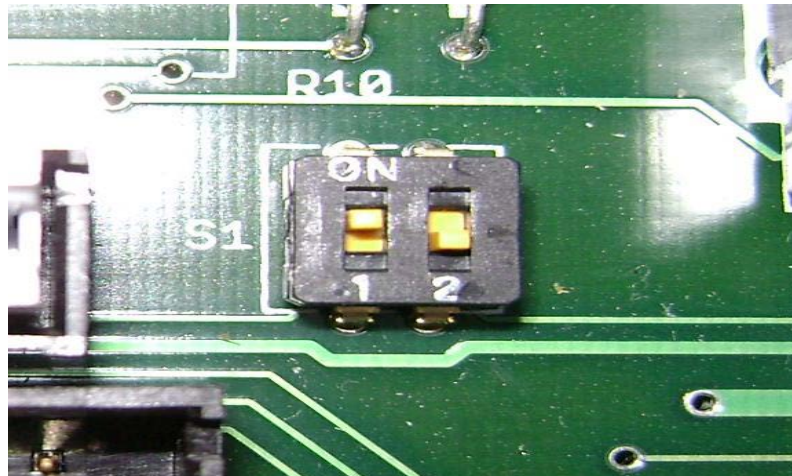

SWITCH LOCATION  
ON= UP  
OFF= DOWN

SWITCH 1	SWITCH 2	=	LABELER
OFF	OFF	=	#1
ON	OFF	=	#2
OFF	ON	=	#3
ON	ON	=	#4

DIP SWITCH (S1) IS LOCATED ON MOTHER BOARD. ACCESS TO DIP SWITCH REQUIRES REMOVAL OF SIDE PANEL OF CONTROL BOX.

## SECTION 5

# CLEANING & MAINTENANCE

General Cleaning & Maintenance	5-1
Troubleshooting	5-2
Fault Codes	5-3
Replacing the Main Power Fuse	5-4

## GENERAL CLEANING & MAINTENANCE

The system should be inspected and cared for properly before operation begins. Typical inspection includes confirming correct supply spool loading, web path, checking air pressure, ensuring rollers are clean and free of adhesives, checking pinch assembly operation, and label feed position. Do not attempt to operate system if not in good working order.

Preventative maintenance procedures should be performed at least once per week. This includes removing adhesive and residual build-up from system components, cleaning the label sensor, cleaning the tamp pad, and cleaning the pinch rollers.

To clean adhesive or residual build-up off of guide rollers, brake arms, or the pinch roller assemblies, use only isopropyl alcohol. Other chemicals or abrasive products can cause damage to the system, resulting in poor operation. **Do not use sharp objects or aggressive solvents on the pinch roller assemblies to remove labels or adhesive!**

Use clean, dry, compressed air to remove dust, dirt, or label debris from the label sensor, if applicable. **Do not use any abrasive objects to clean the sensor slot, as it will cause un-repairable damage to the sensor.**

The tamp pad should be cleaned with isopropyl alcohol to remove adhesive or debris build-up. The pad must be clean and smooth for the labels to feed properly. If adhesive is blocking any vacuum holes, use isopropyl alcohol to break down the adhesives and clean the holes. **Do not use sharp objects or aggressive solvents on the tamp pad assembly to remove labels or adhesive!**

For print engine maintenance, refer to the print engine manufacturer's maintenance manual.

## TROUBLESHOOTING GUIDE

If the system malfunctions, it is necessary to determine where the problem exists in a normal sequence of operation. Possible error conditions are listed in the left-hand column to provide a systematic approach to troubleshooting.

<b>Error Condition</b>	<b>Possible Cause</b>	<b>Corrective Action</b>
Unit will not turn on.	A. Blown Main Fuse	Check main power fuse and replace if necessary
Air system will not operate.	A. No air pressure. B. Plugged hose. C. Faulty valve.	Check air supply and filter Fix or replace hose Consult factory
Take-up unit does not turn.	A. Friction plate failure in clutch. B. Mechanical failure in clutch.	Consult Factory
Waste web tension too loose.	A. Clutch tension too low.	Adjust clutch
Waste web breaks.	A. Clutch adjusted too tight. B. Machine Webbed wrong. C. Low quality webbing. D. Friction plate failure in clutch. E. Mechanical failure in clutch.	Adjust clutch Re-web system Consult label manufacturer Consult factory Consult factory
Label double feeds.	A. Label sensor out of adjustment	Adjust gap threshold setting

## FAULT CODES

DISPLAYED FAULT	DESCRIPTION	CORRECTIVE ACTION
Memory Checksum	Data lost in battery SRAM	Consult factory or service provider
Missing Label	Too many labels missing on web	Check label stock
Following Error	Servo motor stalled (Load too high for motor)	Check acceleration value Check for proper label webbing Lower speed
Head Up Fault	Head up limit switch on tamp did not trigger	Check for proper adjustment of head up limit switch Check air to system
Head Down Fault	Head up limit switch failed to switch during the tamp cycle	Tamp duration too small Faulty limit switch Check air to system
Label Not Found	Label not sensed in auto set up	Check label stock Check label sensor Retry auto set up
Label Present Fault / Feed Error	Label present sensor failed to Detect label	Feed error option enable without hardware attached. Label present sensor faulty or miss adjusted
Emergency-Stop	E-Stop on Labeler is "ON"	Remove the E-Stop Condition
Motor Temp Exceeded	Servo Motor Over Heated	Cool Servo Motor / Cycle Power
Servo Drive Fault	Servo motor stalled (Load too high for motor)	Check acceleration value Check for proper label webbing Lower speed
Broken Web Fault	Label Web Broken Label Sensor Blocked  Labeler feed 2X Programmed Label Length and Failed to Detect a Label	Re-Web Labeler Check Label Sensor Turn Off Broken Web Feature Incorrect Value Entered in Label Length in Control
Waiting For Servo	Servo Drive is Powering Up	Wait for Servo Drive
Auto Setup Failed	Label present sensor failed to Detect label	Check For Proper Webbing of Labeler & Re-initiate Feature

## REPLACING THE MAIN POWER FUSE

The circuitry is protected from a current overload by GMA 15A a fast blow fuse. Should the applicator fail to operate, the condition of this fuse should be checked. If the fuse is open, the cause of the overload condition must be determined and corrected prior to replacing the fuse. NEVER replace the fuse with one of a greater AMP rating. The specified rating has been selected to prevent damage and/or injury.

### ACTIONS TO REPLACE THE MAIN FUSE

1. Set the main power switch to the OFF position.
2. Disconnect the AC power cable from the rear of the console.
3. Locate the fuse holder/power cord assembly.
4. Gently press down the fuse holder cover while pulling away from the console.
5. Replace with the spare fuse provided in the holder.

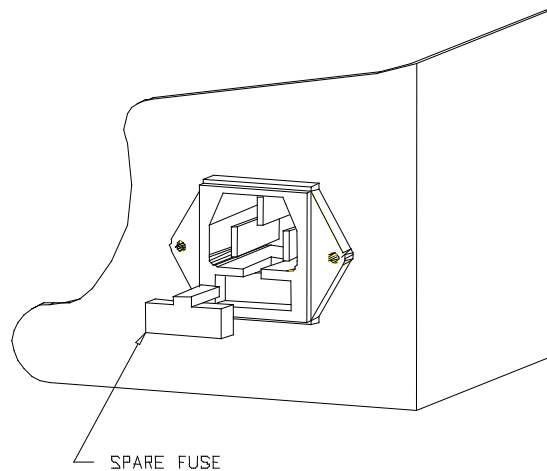



# LM3560

## AUTOMATIC LABEL APPLICATOR

## OPERATIONS MANUAL

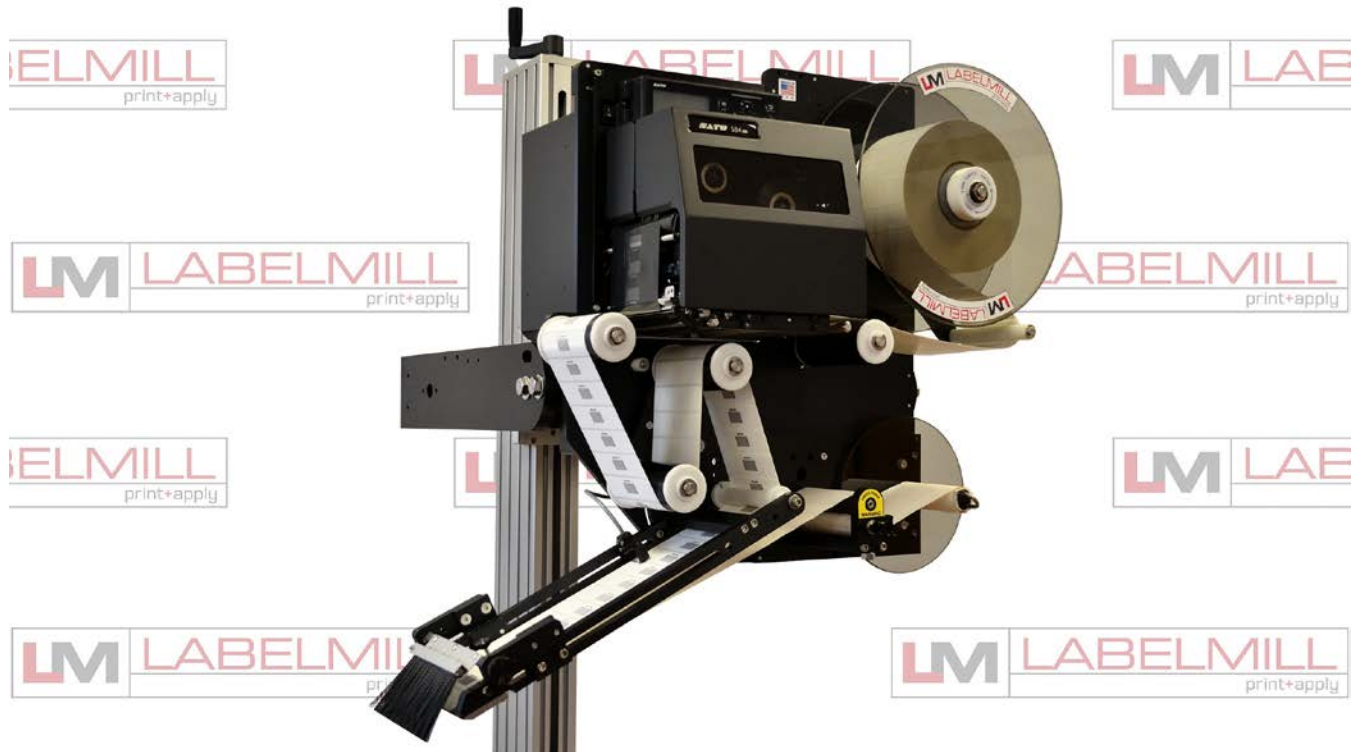

### Copyright and Trademarks

Copyright ©2019 LabelMill  
All rights reserved. All trademarks and brand names  
are the property of their respective owners.

LabelMill  
2416 Jackson St.  
Savanna, IL 61074  
[www.labelmill.com](http://www.labelmill.com)  
[info@labelmill.com](mailto:info@labelmill.com)