



LM4012

AUTOMATIC LABEL APPLICATOR OPERATIONS MANUAL



Manufactured in USA by:

LabelMill, Inc.

2416 Jackson St.

Savanna, IL 61074

(800) 273-4707

info@labelmill.com

www.labelmill.com

TABLE OF CONTENTS

SECTION	PAGE
1. APPLICATOR OVERVIEW	
Introduction	4
General Applicator Specifications	4
Inventory List	5
User Responsibility/Safety	6
2. WEBBING, SETUP AND GENERAL OPERATION	
LM4012 Component Description	8
Web Routing (Synchronous Feed Module)	9
Web Routing (Tamp Module)	10
Label Sensor Position Adjustment	11
Label Sensor Calibration	12, 13
Optional Mechanical Label Sensor	14
Optional Electronic Clear Label Sensor	15, 16
Drive Motor Pack Assembly	17
Adjusting Web Tension (Clutch Adjustment)	18
T-150 Mounting Stand (Optional)	19
T-Stand Adjustment	20, 21
3. SETUP & ADJUSTMENT	
Quick Start	23
Setup of Key Features	24
Synchronous Feed (Wipe-On) Setup	25
Valve Pack	26
Tamp Assembly & Setup	27
Smart Tamp Assembly & Setup	28
Tamp Blow Assembly & Setup	29
Flag Assembly & Setup	30
4. PROGRAMMING AND CONTROL OPERATION	
Hand Held Labeler Interface (HLI-200)	32
Control Accessory Connections	33
Programming	34
System Editor & Programming Menus	35-74
Input & Output Description	75
Logic Board	76-78
5. TROUBLESHOOTING & MAINTENANCE	
General Cleaning & Maintenance	80
Troubleshooting	81
Fault Codes	82
Replacing the Main Power Fuse	83

SECTION 1

APPLICATOR OVERVIEW

Description	Page
Introduction	4
General Applicator Specifications	4
Inventory List	5
User Responsibility & Safety	6

LabelMill LM4012

DYNAMIC LABEL APPLICATOR

The **LabelMill LM4012** is a state of the art, medium speed, heavy-duty industrial Label Applicator. Label applications up to 1400 linear inches of label web per minute are combined with an exceptional placement accuracy of up to +/- 1/32", with multiple methods of application. Products may be labeled in any attitude (top, side or bottom) when used in conjunction with available product handling systems. Outboard-supported drive roller to minimize vibration induced label misplacement. Hybrid servo motor drive. Hardened steel peeler plate for reduced wear with high-speed continuous label application. Adjustable label sensor for expediting changeover without sacrificing accuracy. The **Model LM4012** is transferable from one production line to another when mounted on the **LabelMill Model T-150 Stand**. The **Model LM4012** applicator is of modular design and features rapid changeover from a wipe-on system to a tamp system using the same applicator platform and controller. The microprocessor controls the hybrid servomotor for accurate and consistent label placement. The **Model LM4012** uses a HLI-200 (Hand Held Labeler Interface) with touch screen display and for ease of set-up to include label feed speed (IPM), product delay, batch count, total count, tamp duration and more.

SPECIFICATIONS

Size:	26"H x 32"W x 23"D Weight – 50 lbs.
Electrical:	100-240V AC, 50-60 Cycle, 5 amps
Product Sensing:	Photoelectric or Mechanical Limit Switch
Label Roll Size:	12" Max Outside Diameter, Wound on 3" I.D. Core
Labeling Speed:	1400 Linear Inches of Web per Minute, Standard
Label Style Requirements:	Die-Cut, Waste Removed, with Minimum of 1/8" Separation Between Labels in Running Direction
Label Placement Accuracy:	Up to +/- 1/32" When Labels are Produced to Specifications and Product Handling is Controlled
Options:	Right or Left-Handed Wipe-On, Tamp, Blow-On, or Swing-Tamp*
Standard Label Sizes: *	4 1/2" Wide, 12" Long or optional 6 1/2" Wide, 12" Long*

*Optional lengths and sizes available

*Customs Available

INVENTORY LIST

Qty	Description
1	Applicator Assembly
2	12-½” Dia. Blue Plastic Spools w/ Quick Release Collar
1	7-¾” Dia. Take-Up Spool
2	½” – 13 Bolts w/ Washers
1	10’ Power Cord
1	Product Switch (Manual Limit Switch/Photo Eye Switch as Specified)
1	Take-Up Spool Clip
1	Electronic Web Sensor
1	Model LM4012 Operators Manual

USER RESPONSIBILITY

This equipment will perform in conformity with the description thereof contained in this manual and accompanying labels and/or inserts when installed, operated, maintained, and repaired in accordance with the instructions provided. This equipment must be checked periodically. Defective equipment should not be used. Parts that are broken, missing, plainly worn, distorted, or contaminated should be replaced immediately. Should such repair or replacement become necessary, we recommend that a request for service advice be made.

This equipment or any of its parts should not be altered without the prior written approval of LabelMill. The user of this equipment shall have the sole responsibility for any malfunctions which results from improper use, faulty maintenance, damage, improper repair or alteration by anyone other than LabelMill, or a service facility designated by LabelMill.

SAFETY

- Only qualified personnel should use this equipment.
- Before installing, inspecting or servicing equipment, turn OFF all power and air controls at the source and lock out in accordance with OSHA Standards.
- Be sure all external electrically conductive parts are connected to a good electrical ground.
- Never handle live electrical equipment with bare hands while standing in water, or while hands and feet are wet. Dangerous electrical shock can result.
- Whenever the equipment is unattended, turn off all control and power supply switches.
- Keep equipment clean and in good operating condition. Promptly repair or replace all worn or damaged hoses, cables or parts.
- Do not make any repairs to equipment unless you are fully qualified.
- This equipment contains fast moving parts, which may move without warning. Keep hands, loose hair and clothes clear of machines at all times.
- Never place hands or any other body parts under the label platen at any time.
- This equipment uses compressed air. Proper care and maintenance must be taken when handling compressed air and its components.
- These precautions are further detailed and explained where specifically required in this manual.



WARNING

READ AND UNDERSTAND THESE INSTRUCTIONS

Protect yourself and others. Be sure this information is read and understood by all operators.

ELECTRICAL SHOCK CAN KILL!

Do not touch live electrical parts with bare skin or work with gloves or wet clothing.

NOISE CAN DAMAGE HEARING!

Wear proper ear protection.

SECTION 2

WEBBING, SETUP & GENERAL OPERATION

Description	Page
LM4012 Component Description	8
Web Routing (Synchronous Feed Configuration)	9
Web Routing (Tamp Configuration)	10
Label Sensor Position Adjustment	11
Label Sensor Calibration	12, 13
Optional Mechanical Label Sensor	14
Optional Electronic Clear Label Sensor	15, 16
Drive Motor Pack Assembly	17
Adjusting Web Tension (Clutch Adjustment)	18
T-150 Mounting Stand (optional)	19
T-Stand Adjustment	20, 21

COMPONENT DESCRIPTION

NOTE: LM4012 SYNCHRONOUS FEED CONFIGURATION (LEFT HAND) SHOWN FOR REFERENCE ONLY

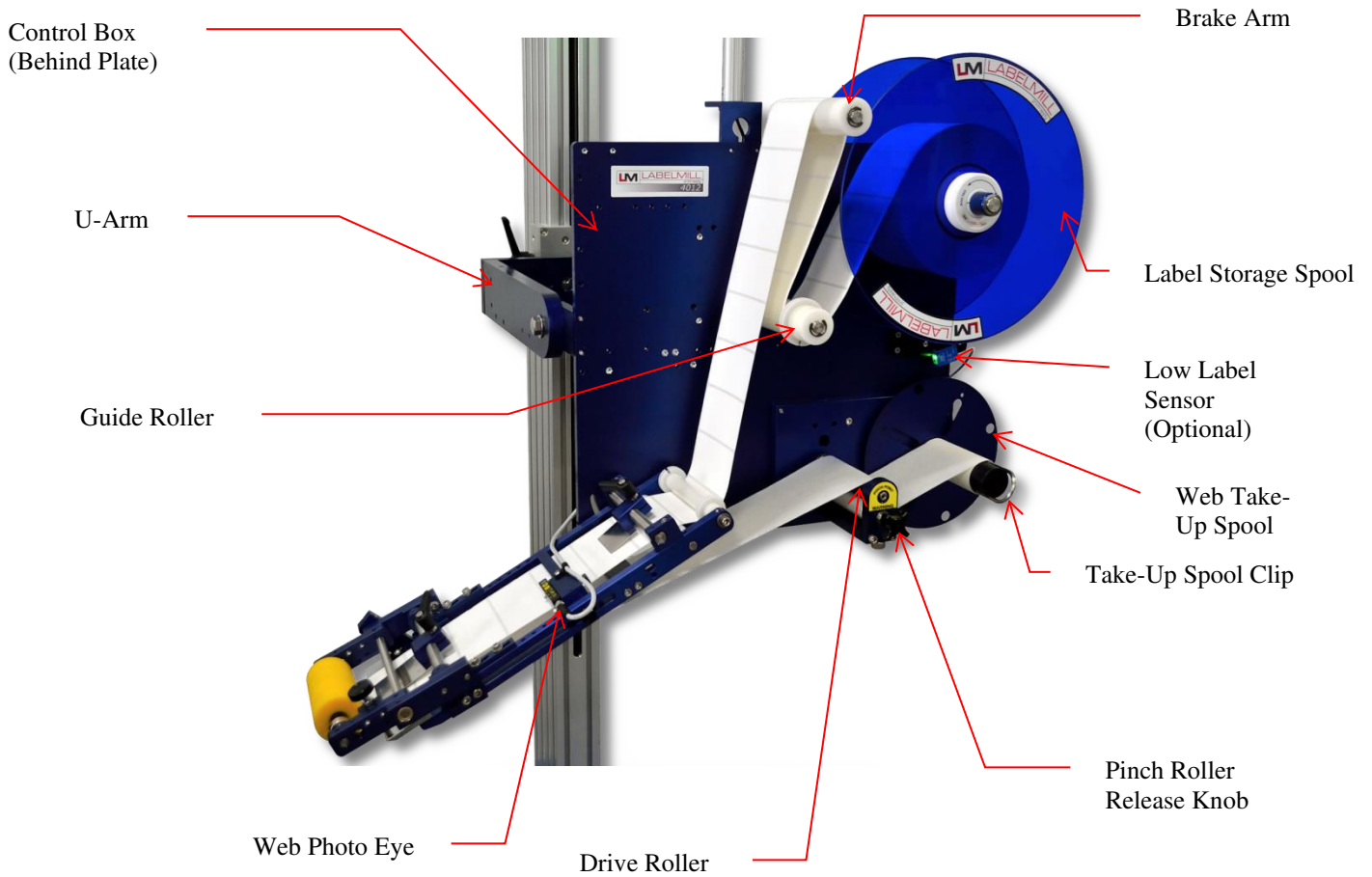

WEB ROUTING

(Right Hand - Synchronous Feed Configuration)

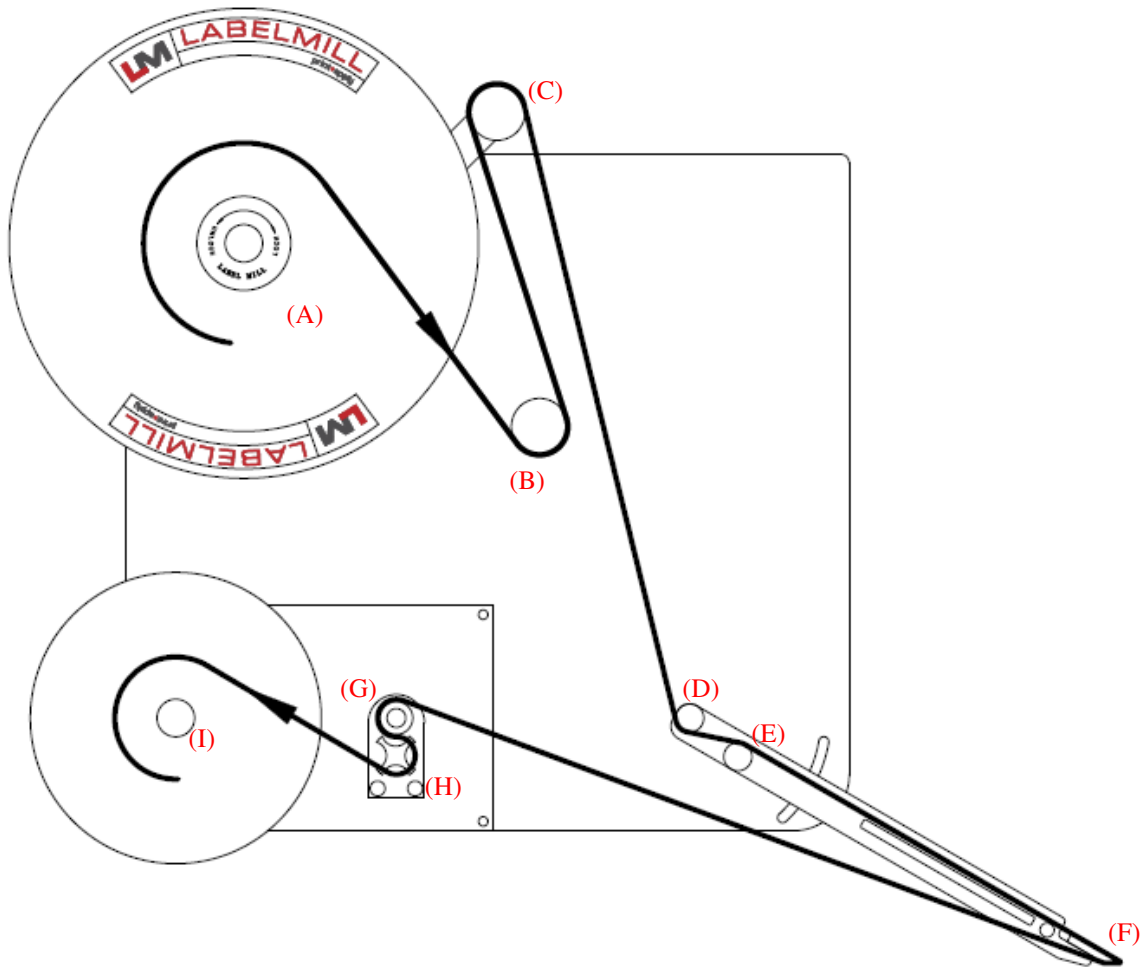

Step	Operation
1	Load web onto label storage spool (A) so it unloads in a clockwise direction.
2	Feed the web to the right and under the idle roller(B).
3	Feed the web up and overbrake arm roller(C).
4	Feed the web under roller(D)and over roller(E). Feed web through label sensor.
5	Wrap the web around peeler plate (F) and pull the web back towards pinch assembly slip the web between the drive roller and the pinch roller (F). Continue on by wrapping the web under the pinch roller (F).
6	Feed the web over drive roller (G), between both rollers, and under pinch roller (H)
7	Finish the process by loading the waste backing paper onto the web take-up shaft(I). Install the take-up spool clip over the end of the waste backing paper. The take-up spool rotates in a counter-clockwise direction.
8	Adjust the plastic web guide clips so the web is guided straight and even. Make sure the clips do not bind the web.
9	Lock the wiper assemblies with light tension, and close the pinch roller assembly.

** To remove the label storage spool (A), turn the spool lock counterclockwise until you reach a stop. The spool will now slide off. To secure the spool, simply turn the spool lock clockwise until snug. DO NOT over tighten!

WEB ROUTING (Right Hand -Tamp Configuration)

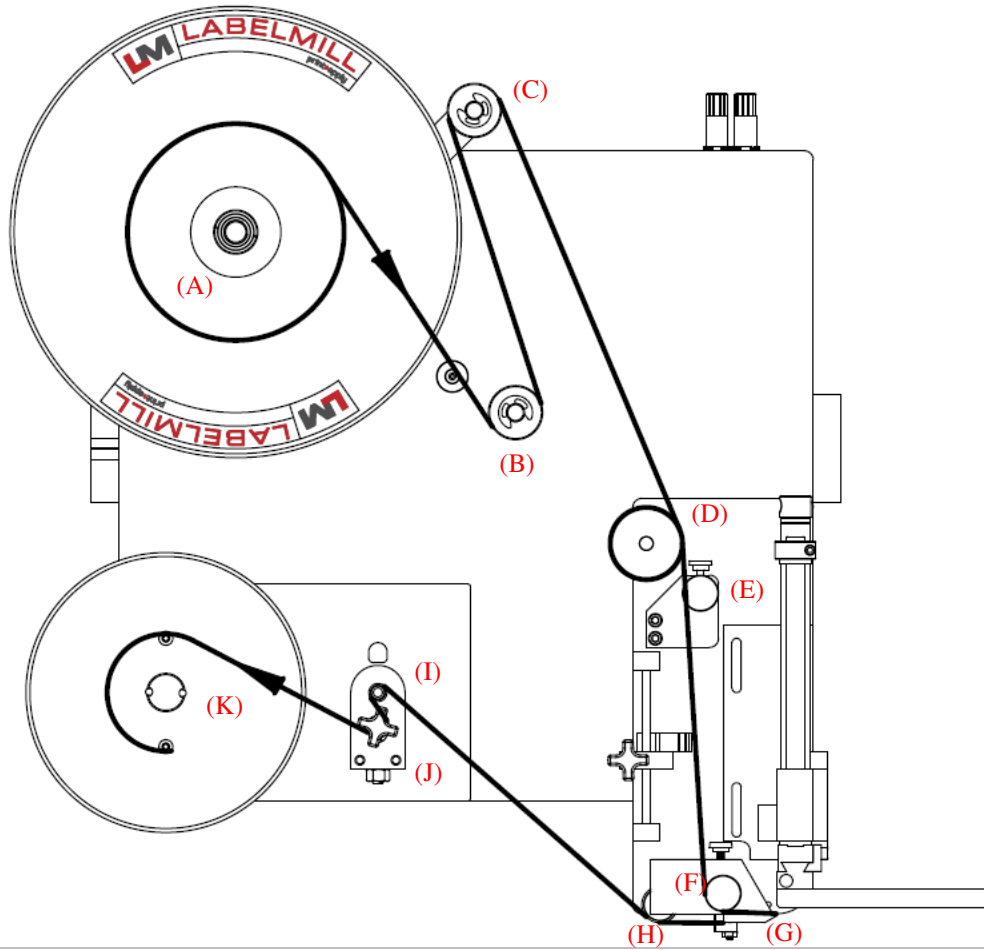

Step	Operation
1	Load web onto label storage spool (A) so it unloads in a clockwise direction.
2	Feed the web to the right and under idle roller (B).
3	Feed the web up and over brake arm roller (C).
3	Feed the web down and over guide roller (D) and through wiper assembly (E).
4	Feed the web under idle roller (F), continuing around peeler plate (G).
5	Ensure web is fed between the peeler plate and air assist tube. Feed the web under idle roller (H), and continue up to the pinch assembly.
6	Feed the web over drive roller (I), between both rollers, and under pinch roller (J)
7	Finish the process by loading the waste backing paper onto the web take-up spool (K). Install the take-up spool clip over the end of the waste backing paper. The take-up spool rotates in a counter-clockwise direction.
8	Adjust the plastic web guide clips so the web is guided straight and even. Make sure the clips do not bind the web.
9	Lock the wiper assemblies with light tension, and close the pinch roller assembly.

** To remove the label storage spool (A), turn the spool lock counter-clockwise until you reach a stop. The spool will now slide off. To secure the spool, simply turn the spool lock clockwise until snug. DO NOT over tighten!

LABEL SENSOR POSITION ADJUSTMENT (Synchronous Feed Configuration Shown)

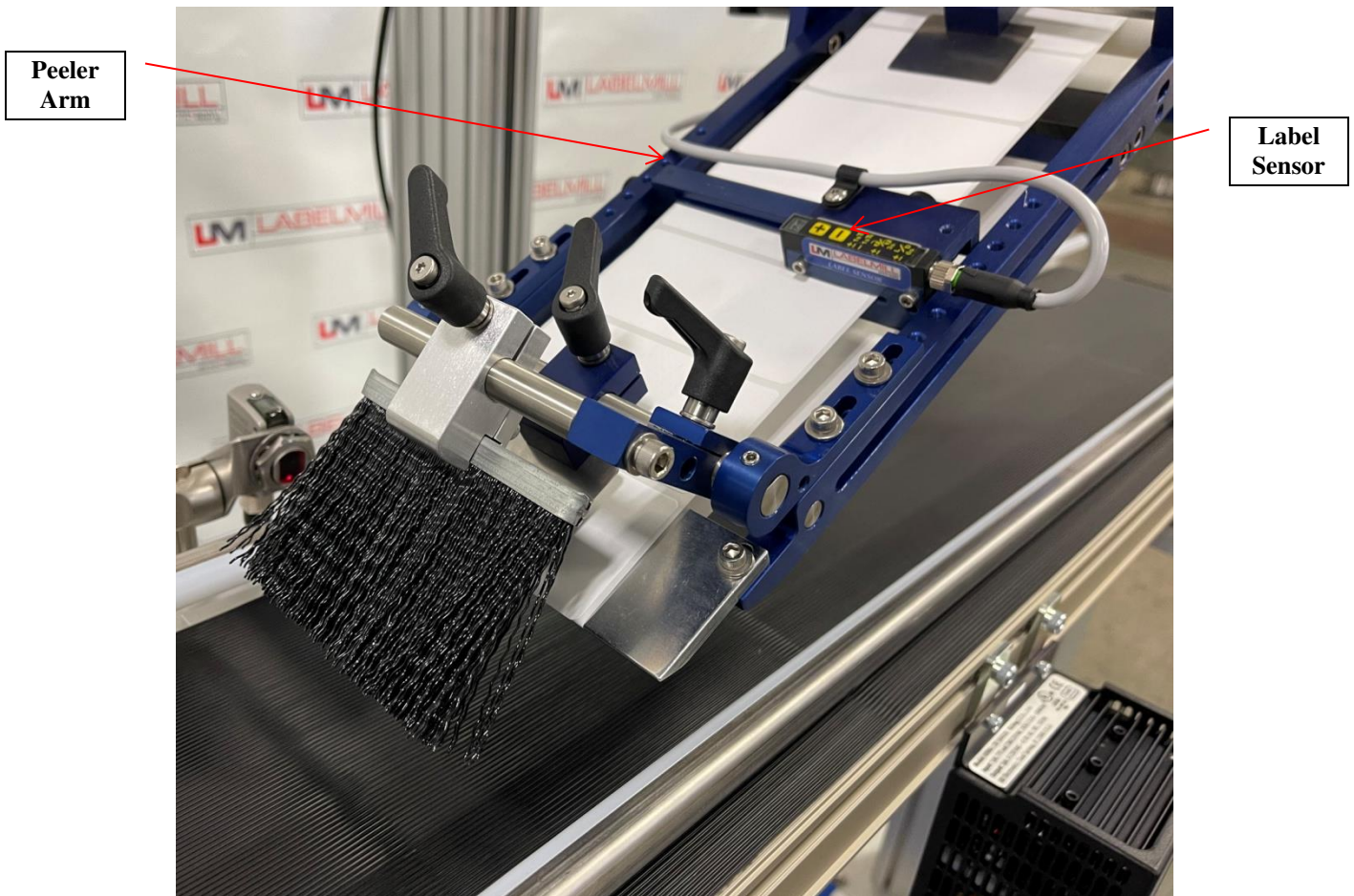

The label web must be fed through the label sensor slot to detect the label. Once the system is webbed with labels, loosen the thumbscrew that mounts the label sensor, and slide it into the web.

Manual adjustment of the label in relation to the peeler plate is achieved by loosening the thumbscrew on the label sensor bracket and sliding the assembly up or down on the peeler arm rail.

Once the label sensor is manually adjusted, calibrated correctly, and properly configured in the control, trigger the applicator to test the position of the label in relation to the peeler plate.

The label position should be adjusted so that the label stops at the edge of the peeler plate. If the label is not fully removed from the liner, or if the label has fed out too far past the edge of the peeler plate, additional adjustment is required.

Z-Z-ELS100 LABEL SENSOR CALIBRATION INSTRUCTIONS

Quick Start Setup

1. Ensure the cable is secured to the sensor and plugged into the “Label Sensor” port on the control box. The LED light will illuminate RED or GREEN if the sensor has power.
2. Remove a label from the liner and adjust the label web so that only the liner without a label is positioned in the sensor slot.
3. Press and hold the “Autoset” button for 1 second. The LED will turn YELLOW during calibration.
4. When successful, the LED light will turn RED when over a gap, and GREEN when over a label.
5. If false triggering occurs, tap the “+” (Autoset) button or the “-” (LT/DK) button to increase/decrease the sensor threshold.
6. Setup Complete

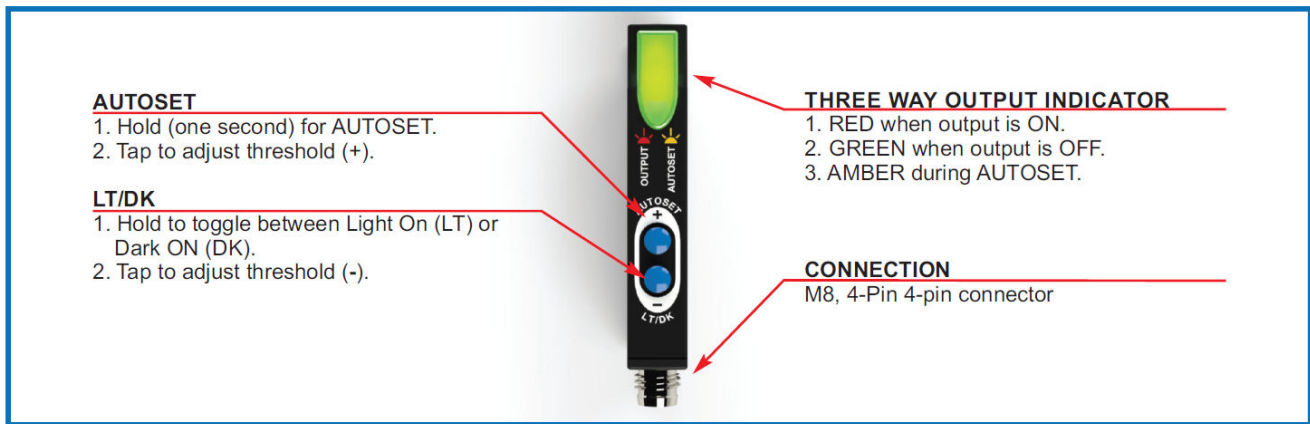

***Note that the Red Light on the label sensor should be illuminated when the sensor is detecting a Gap, and the Green Light should be illuminated when the sensor is detecting a Label.**

Alternative Electronic Sensor Option

Teach Mode Setup Procedure:

1. Place the web liner in the sensor (remove a label or use the label gap). Press the [+] and [-] buttons at the same time for less than one second. The red LED will begin to flash.
2. Place the web liner, **with a label**, in the sensor. Press the [-] button for less than one second. The red LED will stop flashing.
3. The automatic setup is complete. (Steps 1 and 2 can be reversed)



Manual Sensitivity Adjustments:

The "Teach Mode Setup" should always be successful. However, the sensitivity can be adjusted manually by pressing the [+] or [-] buttons. The red LED will flash with each button press.

Locking/Unlocking the Setup:

Press and hold the [+] and [-] buttons for three seconds (but less than six seconds). The red LED will change state. When the buttons are released, the red LED will then indicate locked (red LED on) or unlocked (red LED off).

Light/Dark Switching:

Press and hold the [+] and [-] buttons for six seconds. When the mode is changed, the red LED will begin to flash slowly until the buttons are released.

***Note that the Amber Light on the label sensor should be illuminated when the sensor is detecting a Gap, and there should be no light illuminated when the sensor is detecting a Label.**

OPTIONAL MECHANICAL LABEL DETECTOR

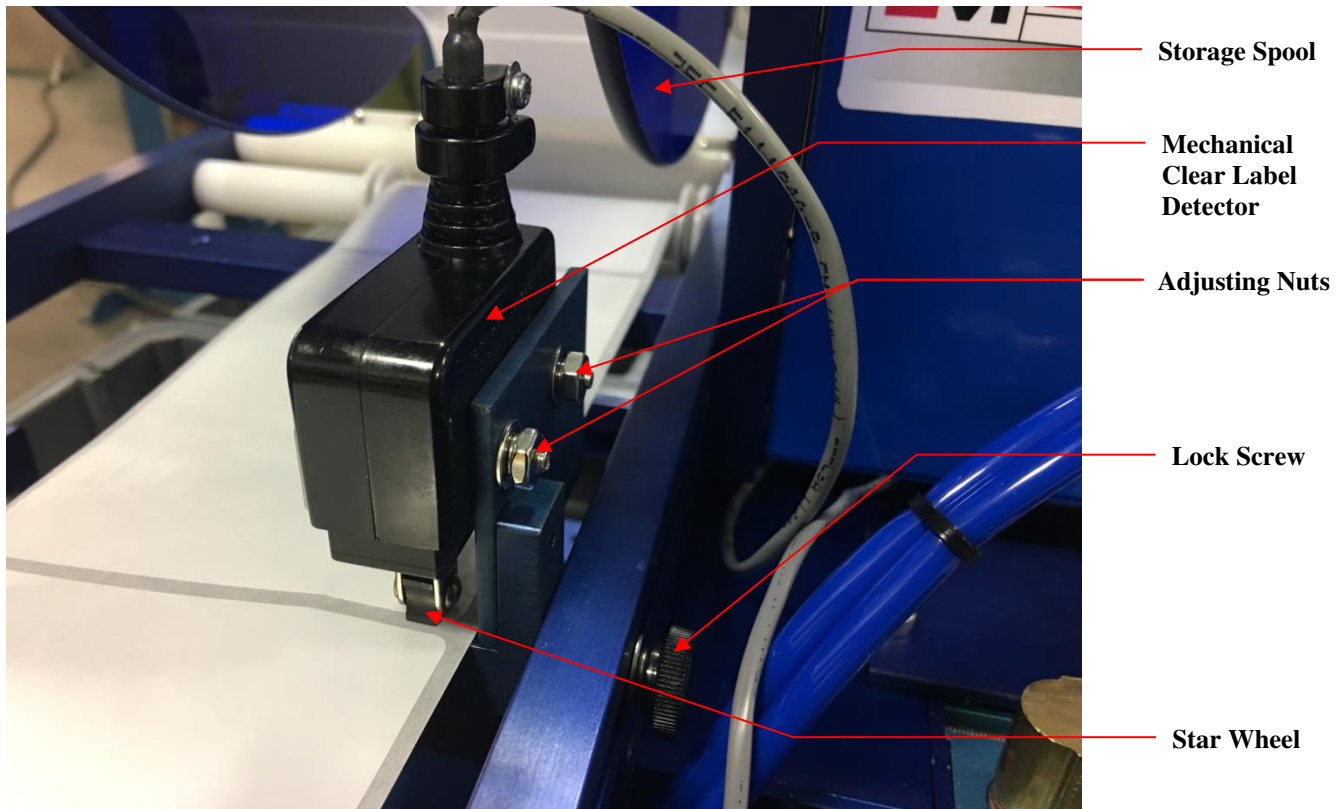

The Mechanical Label Detector comes preset from the factory and should require no adjustment. If there is a need to readjust the sensor, the following is a guide: Move the label stock until the gap between the labels are centered under the Star Wheel and the star wheel is laying flat on the label stock as shown above. This can be accomplished by unwinding the label storage spool enough to make the web "loose". To test adjustment, move the label stock gap back and forth under the photo eye slowly. The STAR WHEEL catches the edge of the label stock and flips from one flat to the next. The STAR WHEEL detects the gap between the labels by catching the edge of the label as it is fed. When the star wheel catches the edge of the label, the wheel will stop sliding and rotate. The diameter across the flats of the star wheel is smaller than the diameter across the points. When the star wheel rotates, the micro switch is activated indicating the gap in the label stock.

If double or multiple label feeding occurs, and the micro switch is always activated, loosen the adjustment nuts and slide the micro switch up away from the label.

If double or multiple label feeding occurs, and the micro switch never activates, loosen the adjustment nuts and slide the micro switch down towards the label.

LABEL PLACEMENT IN RELATION TO THE PEELER PLATE:

Loosen the lock screw on the **Mechanical Label Sensor Assembly** and slide it forward or backward on the adjustment rails to achieve placement of the label with the peeler plate nose (+/- 1/32). After adjustment, cycle the labeler to verify new label placement.

OPTIONAL ELECTRONIC CLEAR LABEL DETECTOR (ECLD)

Quick Start Setup

1. Ensure the cable is secured to the sensor and plugged into the "Label Sensor" port on the control box.
2. The Label web must remain in contact with the stainless-steel gap plate during calibration.
3. Adjust the label web so that the gap between labels is centered with the alignment marks on the sensor.
4. Press and hold the "Autoset" button for 2 seconds. The green LED will flash during calibration.
5. When successful, the red LED "Output" light will illuminate when over a gap.
6. If false triggering occurs, tap the "Up" (Autoset) button to reduce the threshold, or tap the "Down" (LT/DK) button to increase the threshold.
7. Setup Complete



Troubleshooting

- Press and hold the "LT/DK" button to toggle between light on or dark on.
- A flashing Red (Output) light indicates a short circuit or overload has been detected.

ALTERNATIVE CLEAR LABEL SENSOR OPTION

Description

The Z-Z-ELC300 Label Sensor uses capacitive technology to sense label edges for registration, counting, splice detection or other applications. Capacitive technology provides the fastest and most accurate edge detection method available. The Z-Z-ELC300 has an integral cable, and uses an M12 connector.

Setup

1. Web must remain in contact with the base/mounting plate during operation.
2. Label must pass under the [-SENSOR-] indicator.
3. Small labels should be centered under the [-SENSOR-] indicator.
4. When properly setup, the lights in the gray LABEL area will be on when a label is present, and lights in the gray GAP area will be on when a gap is present.
5. All lights flashing rapidly indicates over-current condition, likely caused by wiring error.

AutoGap Setup

1. Start with High Gain off.
2. Remove a label from the web.
3. Place the area of the missing label in the sensor (liner only).
4. Press for at least 1 second (lights begin to move back and forth).
5. Release the button.
6. Setup complete.
7. Verify the light bar goes into the gray GAP area during gaps between labels and into the

gray LABEL area during labels. If necessary, use arrow keys to adjust manually. If the light bar is not moving at least three or four lights, turn on High Gain.

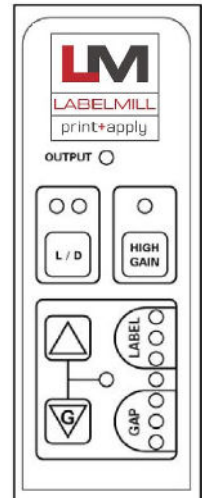

Manual Adjustment

When running, the light bar should extend from the gray LABEL area to the gray GAP area. The up and down arrows can be used to fine tune the adjustment if necessary. If the adjustments reach the end of their range, the last light in the GAP or LABEL area will flash three times when the button is pressed. The light bar may move toward LABEL while the Up arrow is pressed. This is because the sensor body is deflecting and making the slot smaller. It will return when the button is released and will not affect setup.

Sensor Configuration

Light/Dark Switching: In “Light” switching mode, the sensor outputs are active/on during the gap. In “Dark” switching mode, the sensor outputs are active/on during the label. Switch modes by pressing the button. Do not change while running.

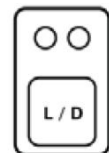

High Gain Mode

Only use High Gain mode when necessary. Very small or very thin labels may not consistently move the light bar between the LABEL and GAP areas. In this case, use the High Gain mode by pressing the button. Do not change while running. AutoGap must be performed after activating High Gain.

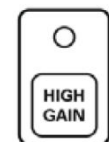

Metal/Foil Label Setup

AutoGap Setup on a missing label area may not work reliably for rectangular metallic labels (foil or metalized Mylar). In this case, place an actual gap in the sensor (use alignment groove on the sensor). Then hold the Gap button down for AutoGap as above. Move labels slowly through the sensor. Use manual adjustments if necessary to ensure the light bar is in the LABEL area during labels and GAP area during gaps.

LM4012 DRIVE MOTOR PACK ASSEMBLY

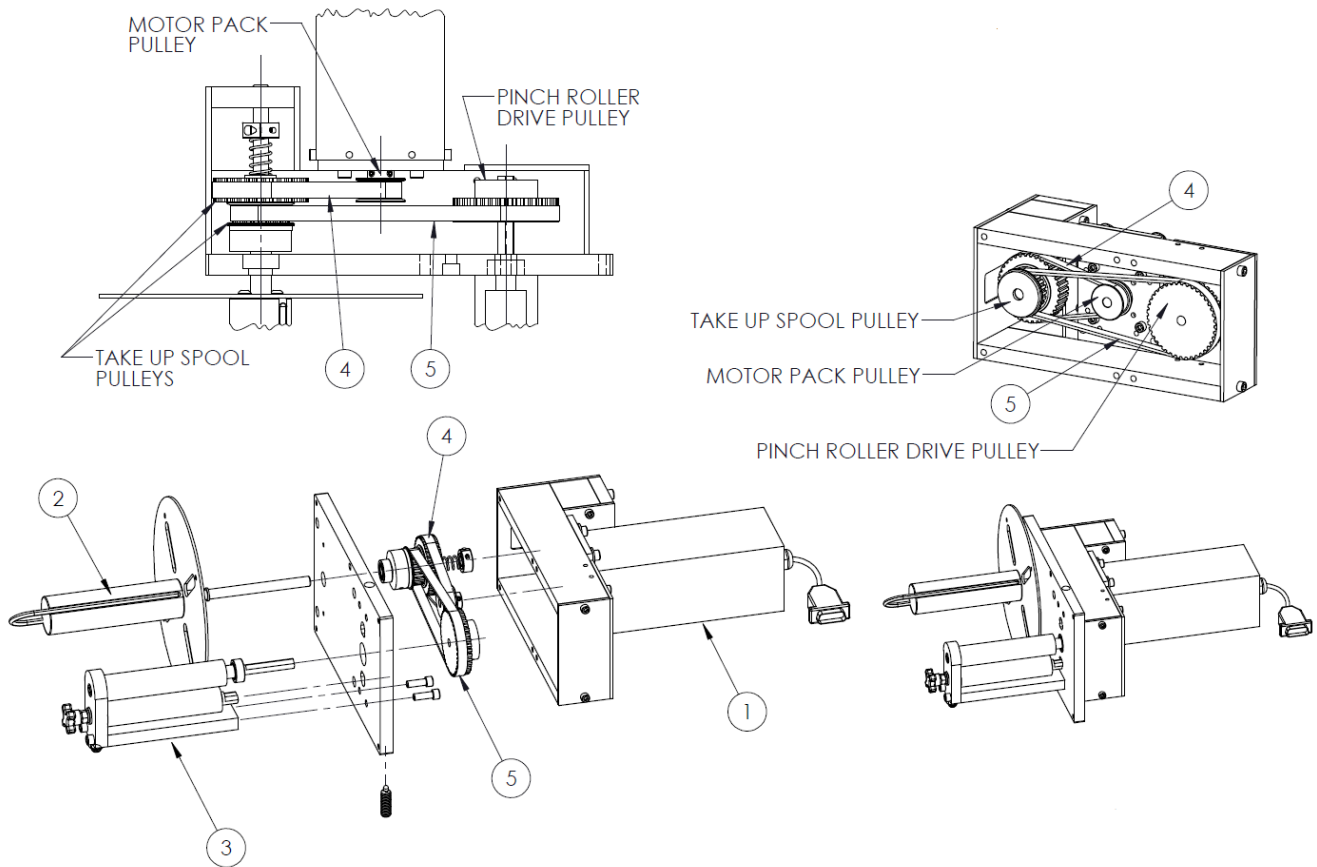

<u>Item #</u>	<u>Part #</u>	<u>Description</u>
1	GB-F-A0010	Drive Motor Assy w/ Cable & Connector
2	CC-F-A0012	Take-Up Assembly
3	A-F-A0013	Pinch Assembly
4	Z-Z-M110	Belt
5	Z-Z-M180	Belt

ADJUSTING THE WEB TENSION

If the web tension becomes too loose or too tight, adjustment of the clutch may be required. To adjust the clutch, remove the motor pack cover plate by removing the (2) cap head bolts.

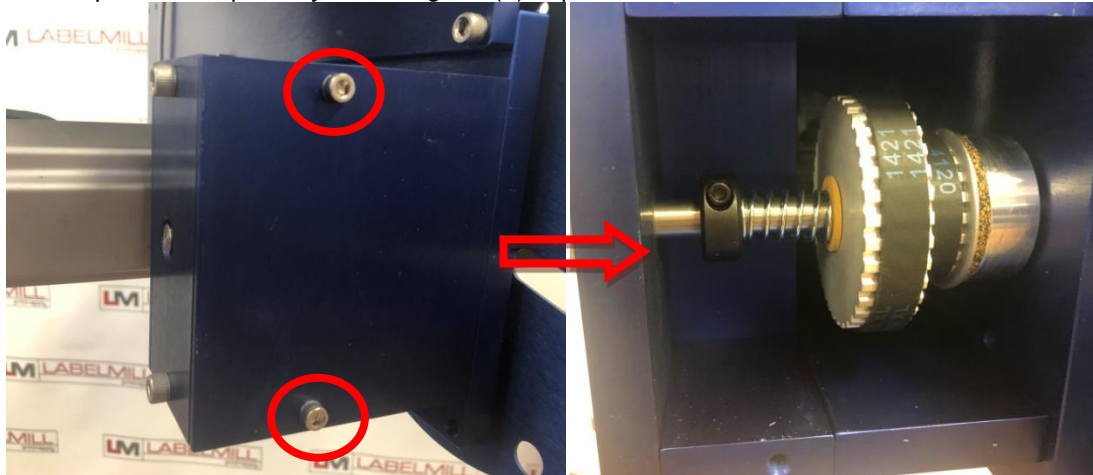

To reduce waste web tension, move the lock collar 1/32" away from the take-up spool. To increase waste web tension, move the lock collar 1/32" toward the take-up spool.

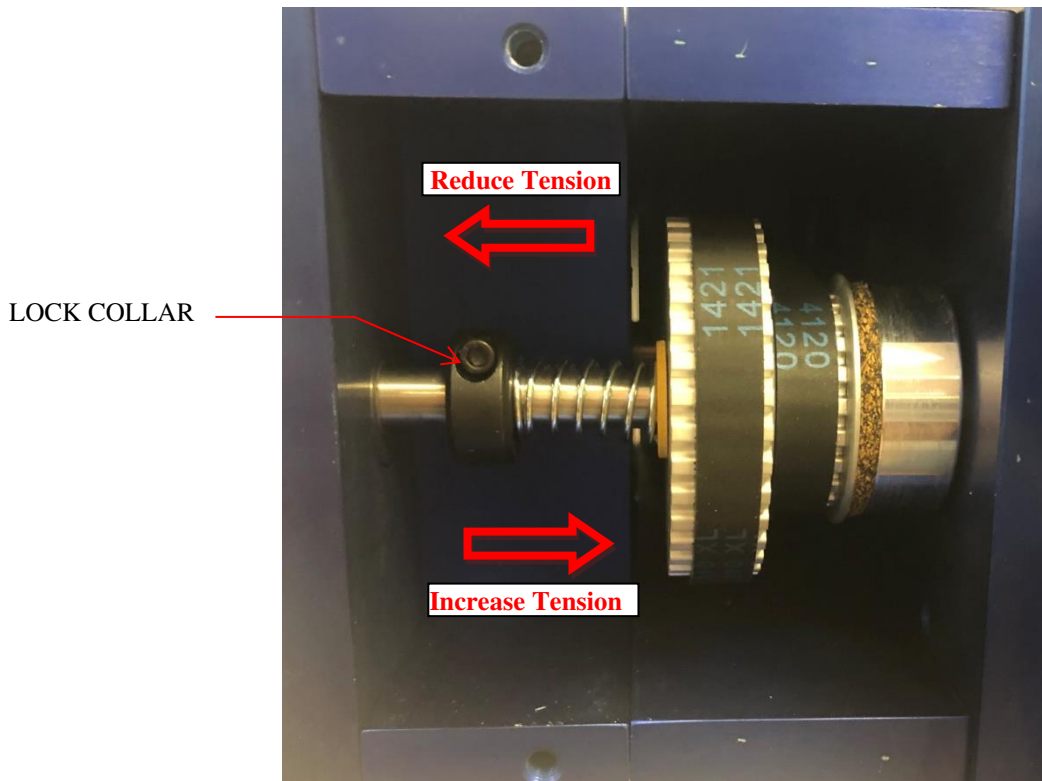

CAUTION! Too much web tension may cause web breakage, label drifting or premature failure of the take-up spool assembly.

T-150 Heavy Duty Mobile Stand w/ Locking Casters



T-StandAdjustment

To adjust the T-150 mounting stand, simply loosen the headlocks and adjust to the desired height by turning the column crank. Be sure to lock the headlocks when finished.

Column Crank



Column Lock

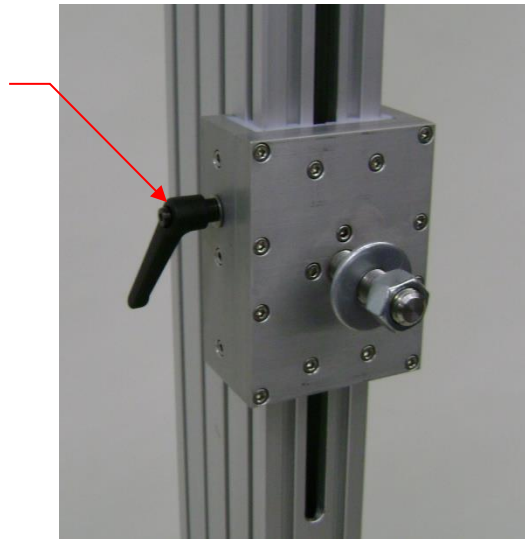

Optional Adjustment Kits for T-Stand

The T-400HK (Horizontal Adjustment Kit) and T-400HK-X (Cross-feed Adjustment Kit) are optional add-ons for making fine adjustments to the position of the label application, when mounted to the T-150 stand.

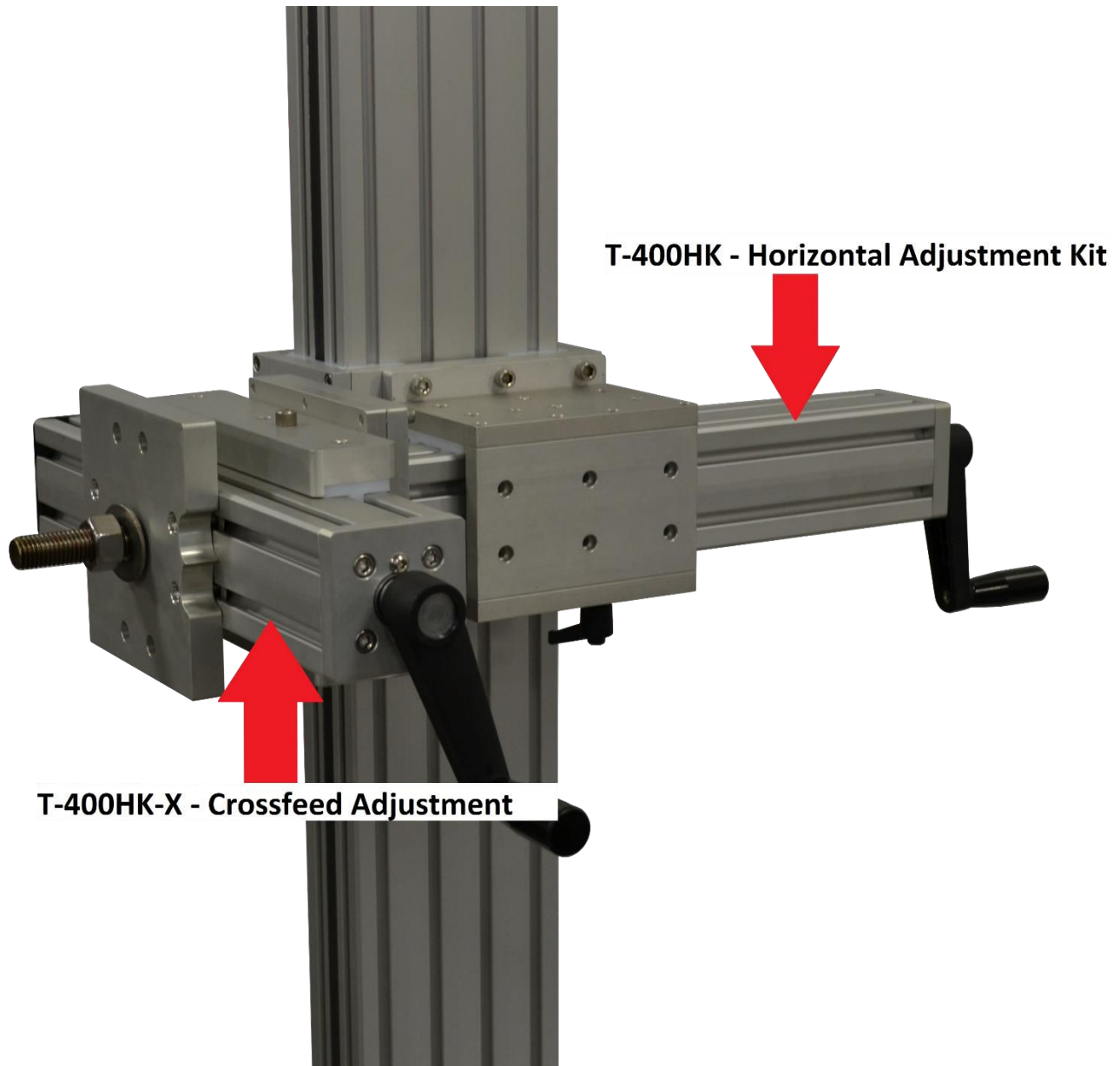

SECTION 3

SETUP & ADJUSTMENT

DESCRIPTION	PAGE
Quick Start	23
Setup of Key Features	24
Synchronous Feed (Wipe-On Assembly)	25
Valve Pack	26
Tamp Assembly & Setup	27
Smart Tamp Assembly & Setup	28
Tamp Blow Assembly & Setup	29
Flag Assembly & Setup	30

QUICK START GENERAL SETUP

INITIAL MANUAL SETUP

1. Inspect applicator system and verify all cables are installed properly.
2. Web system with labels.
3. Turn power switch on and connect air supply.
4. Select "PROGRAM" key on HLI-200 input device.
5. Select the "JOB STORAGE" option.
6. Select the "LOAD DEFAULTS" option (consult factory for setup parameters prior to loading defaults).
7. Select the "YES" option to load the system defaults.
8. Select the "BACK" option to return to the main menu.
9. Select the "EDIT CONFIG" option to enter parameters menu.
10. Select the "LABEL SETUP" option, and program the settings as needed.
11. Select the "CYCLE TYPE" option, and select the appropriate cycle type for the installed module.
12. If a "Tamp" cycle type is selected, select the "TAMP SETUP" option and program the settings as needed.
13. Select the "PRODUCT SENSOR" option, and program the settings as needed.
14. Once setup is complete press "SAVE" key to save the settings to memory exit the programming menu.
15. Cycle the system by pressing the "START" key or by using an input device.
16. Observe label feed speed and change if required.
17. Manually move the label sensor so the label stops flush with the peeler plate tip.
18. System is now ready for set up of advanced features and options.

SETUP OF KEY FEATURES

PRODUCT DELAY

PRODUCT DELAY (in the Product Sensor Menu) is used to electronically move the placement of the label on the product. Product delay will move the label placement in time (00.000). Because the product delay feature utilizes time, the speed of the product **MUST** be constant and consistent.

1. Set basic applicator up first, refer to quick setup
2. Ensure that applicator is operating properly before starting this procedure.
3. Set Product delay to 00.000
4. Start system and apply label at the desired speed.
5. Check the placement of the label on the product.
6. Measure the OFFSET of the label placement. Note: A label **CANNOT** be advanced on the product **ONLY** moved “back” since the applicator can only delay the product signal.
7. Apply a small delay to the product delay or if too great, it may be necessary to physically move the product switch. Keep product delays to a minimum for best results.
8. Operate system again and measure offset.
9. Apply a small delay to the product delay or reduce if too much.
10. Test again; repeat, if necessary, until label is in proper registration.

LABEL STOP POSITION

The LABEL STOP POSITION (in the Label Setup Menu) is used to electronically move the stop position of the label on the applicator only.

The setup below describes how to use the LABEL STOP POSITION feature. This is used to delay the “stop” position of the label relative to the peeler plate. Once a distance is entered into the LABEL STOP POSITION, the label will advance the programmed length past the sensing of the label gap by the label sensor.

1. Set basic applicator up first, (refer to quick setup on the previous page).
2. Operate applicator at desired label speed.
3. Manually move the label sensor to adjust the label stop position of the label. The proper stop position will be with the leading edge of the label stopping flush with the tip of the peeler plate.
4. Operate the applicator again at the same speed.
5. Does the label stop at the tip of the peeler plate? Yes = task complete / NO = continue
6. Measure the distance required to stop the label flush with the peeler plate, and enter this value (in inches) in the “LABEL STOP POSITION” menu option.
7. Operate system at the same speed again and check label offset.
8. Test again; repeat, if necessary, until label is in proper registration to the peeler plate tip.

Note: The label stop position distance **CANNOT** be greater than half the length of the label. If the label stop position is too large, it may result in inconsistent feeding and/or double label feeding may occur.

Synchronous Feed Assembly & Factory Setup

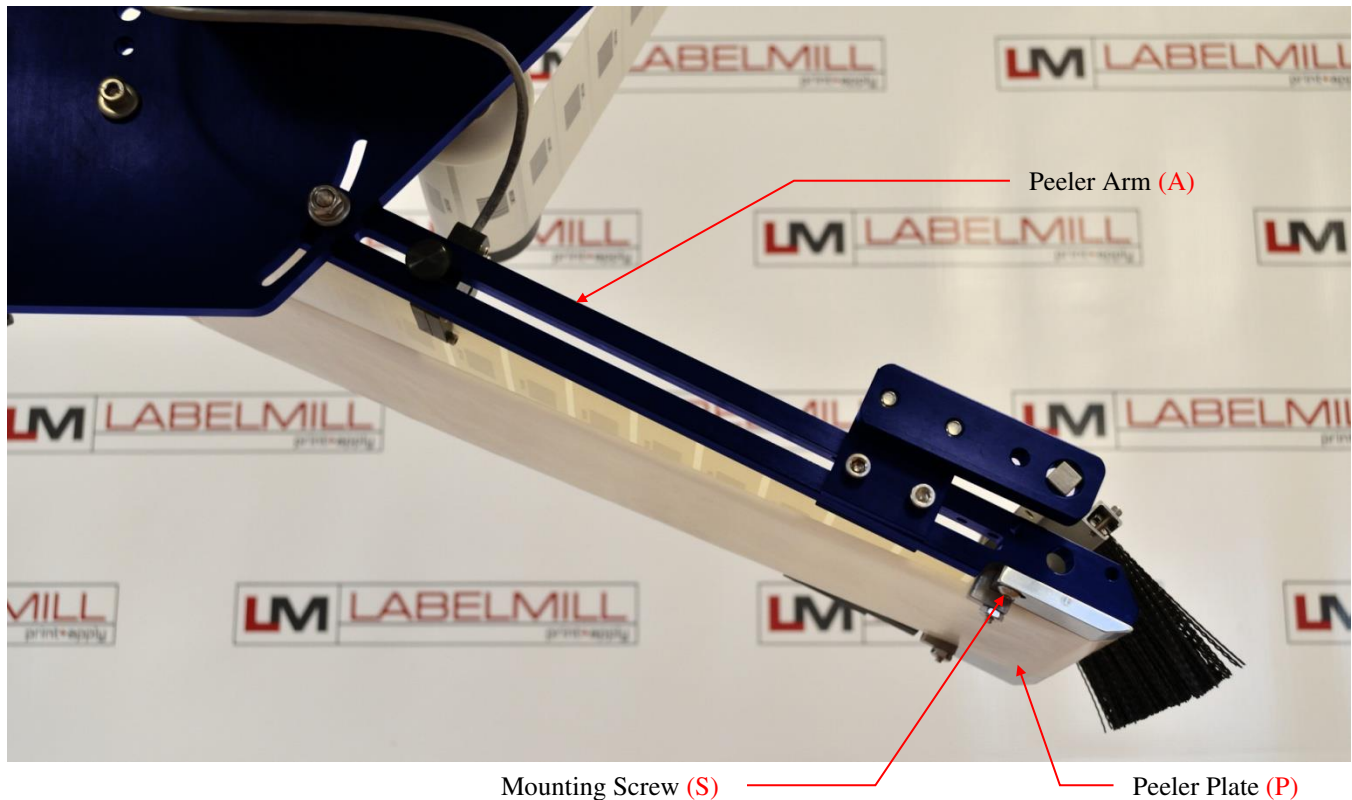

Peeler Plate Adjustment (used to adjust tracking)

1. Loosen the mounting screws (S) and slide the peeler plate (P) in the direction needed to make the label web track in the desired direction.
2. Retighten the mounting screws (S) to secure the peeler plate (P) after adjustments are made.
3. Now that the plate is adjusted, test run the machine to see if the web tracks correctly.

NOTE: If the web tracks towards the back plate, adjust the end of the peeler plate (P) that is closest to the back plate away from the back plate or the opposite end toward the back plate. Adjust the peeler plate (P) in the opposite direction if the web tracks away from the back plate.

VALVE PACK (Not Included in Synchronous Feed Configuration)

There is solenoid valves associated with applicators using pneumatics. They are supplied with pre-wired cables that connect to the necessary components.

There is an adjustment for airflow for each valve. This will change the rate at which air will flow through each valve. It may be necessary to adjust each valve for optimum performance after installation. The adjustments are performed as shown below.

(Pictures may not show actual model)

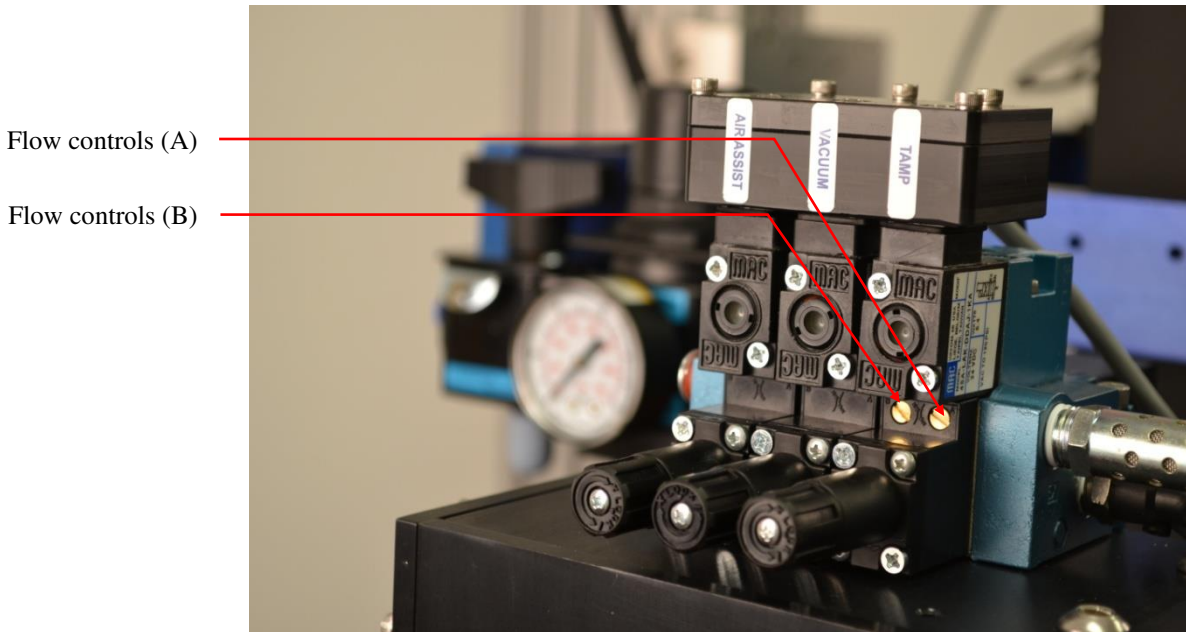

Regulator Adjustment:

Clockwise - Increase pressure **Counterclockwise** - Decrease pressure

FLOW CONTROLS (Tamp & Corner-Wrap Applications)

Control A: This is used to adjust the speed that the tamp cylinder moves in the upward direction.

Control B: Controls the tamp cylinder in the downward direction.

VACUUM REGULATOR

The vacuum regulator is used to control the vacuum that is used to hold the label to the flag jaws or the tamp pad.

AIR ASSIST REGULATOR

The air assist regulator is used to change the pressure that is applied to the blow tube. The blow tube is below the front edge of the peeler plate and is used to help “push” the label onto the bottom of the tamp pad or the flag jaws.

FLAG REGULATOR (Only present if configured with flag applicator head)

The flag regulator is used to adjust the pressure that the flag jaws apply to the label as it is applied.

Tamp Assembly & Factory Setup

NOTE: PICTURES SHOWN MAY NOT RESEMBLE YOUR MODEL

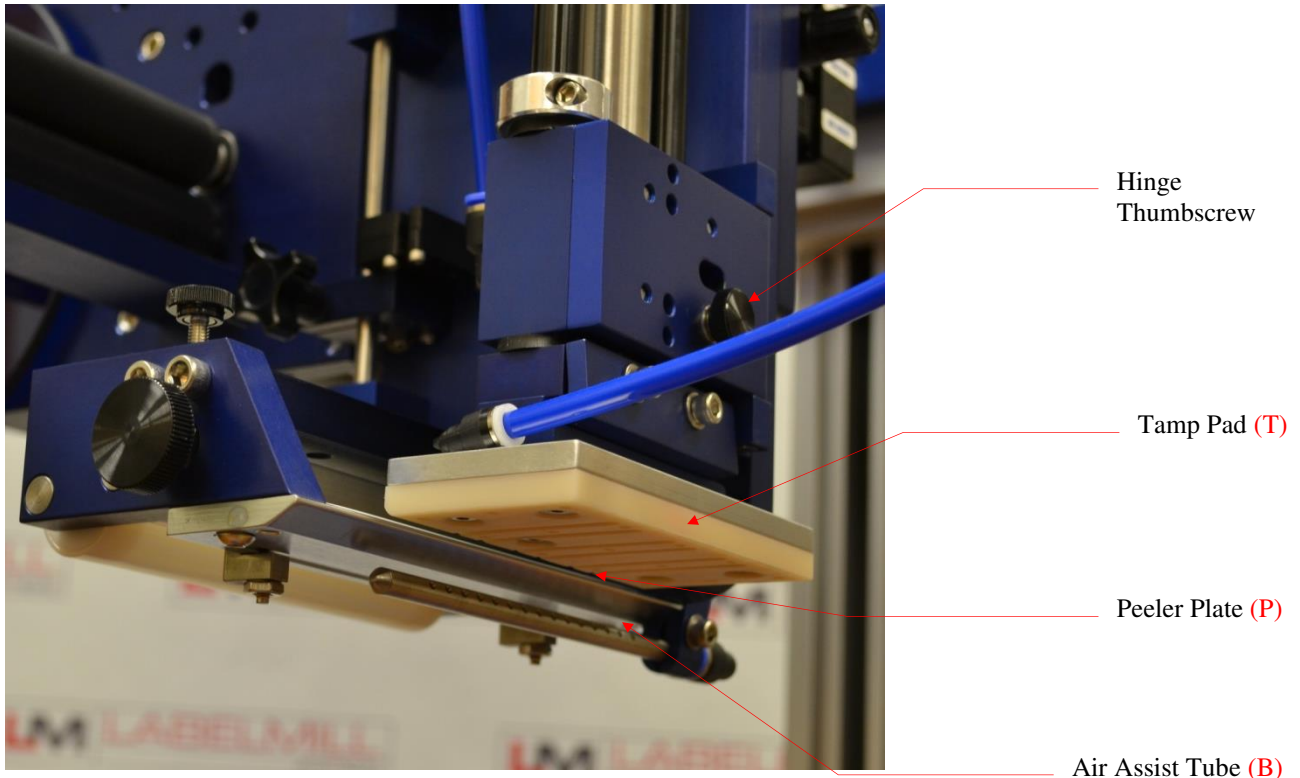

Tamp pad adjustment

1. To adjust the tamp pad (T) in relationship to the peeler plate (P) in the horizontal plain, loosen the (2) button-head screws and move the peeler plate forward or backward in the slots. There should be approximately 0.020" gap between the tamp pad (T) and the peeler plate (P).
2. To adjust the tamp pad (T) in relationship to the peeler plate (P) in the vertical position, loosen the hinge thumbscrew, swing the tamp assembly out, and loosen the (4) cap head bolts that secure the tamp mount assembly in place. Adjust the up or down to achieve the 0.020", tighten the (4) bolts, and secure the tamp assembly in place by tightening the thumbscrew. This adjustment is very important! If this is not adjusted properly, the label will run into the back of the tamp pad (T) and fold or bunch up.

Air assist tube adjustment

1. Adjust the air assist tube (B) so that the small holes aim towards the center of the tamp pad. The air assist tube (B) aids the label to adhere to the bottom of the tamp pad (T). Once the label is "blown" onto the tamp pad (T), it is held there by vacuum.
2. Once the above adjustments are made, adjust the vacuum regulator, the air assist regulator, and the flow controls as necessary.
Note: Too much pressure on the air assist will cause the label to flutter and/or blow off of the vacuum platen.

Smart Tamp Assembly & Factory Setup

An optional Smart Tamp upgrade may be added to the pneumatic linear tamp slide assembly to assist in applying labels at varying distances. The Smart Tamp upgrade features a compression assembly near that tamp pad that will sense when the product has been contacted, and will automatically retract the tamp slide (overriding the programmed tamp duration setting). To achieve this, a fiber-optic sensor is mounted to the end of the tamp slide, along with a small block that will break the beam of the fiber optic sensor, when the slide compresses. The fiber optic cables plug into a photoeye sensor mounted onto the system backplate, which then plugs into the “Smart Tamp” port on the control box.

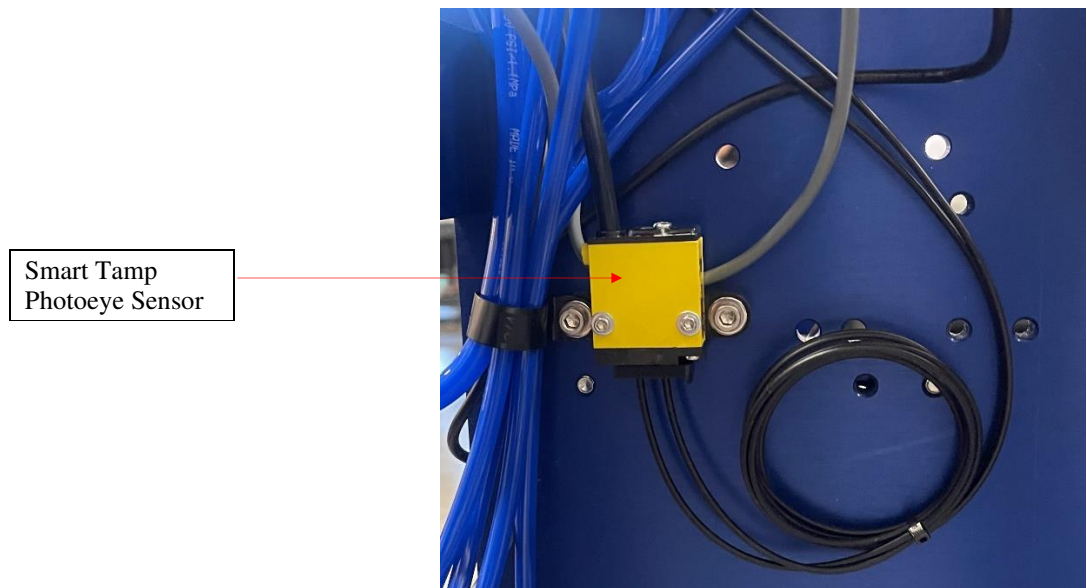
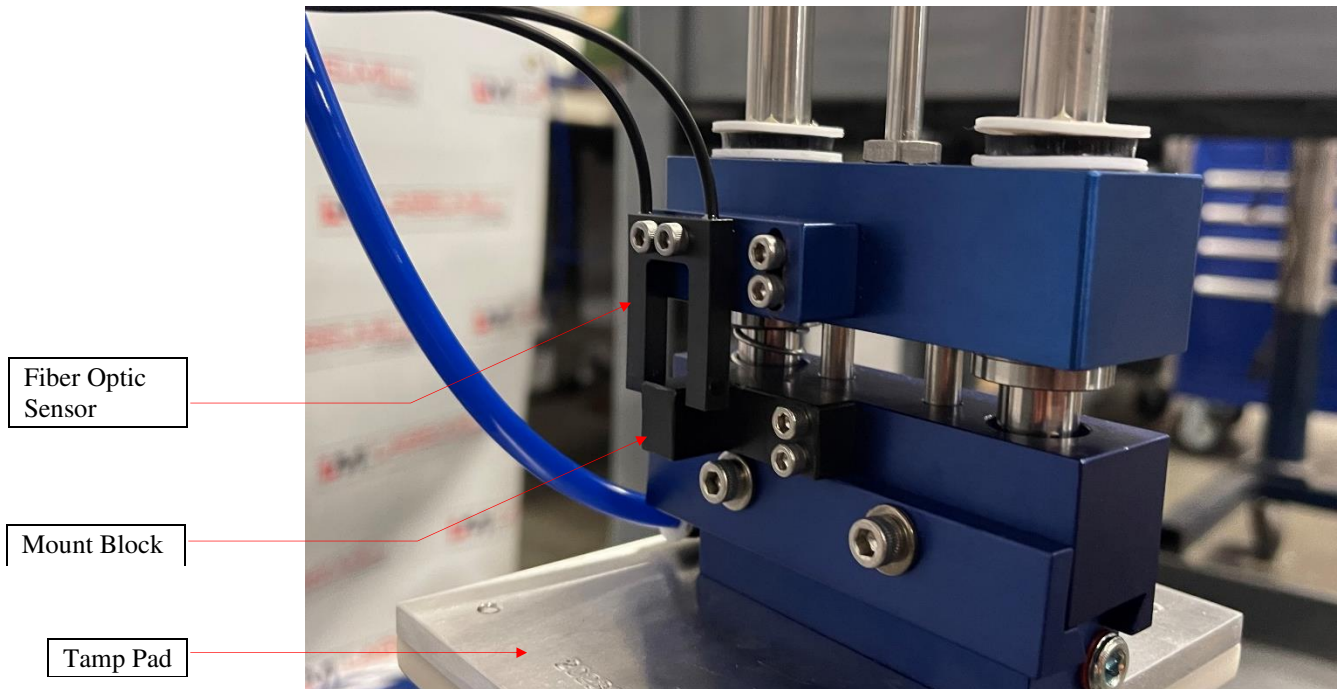

Tamp-Blow Assembly & Factory Setup

An optional Tamp-Blow upgrade may be added to a pneumatic tamp system, to assist in applying labels to curved surfaces, or to apply a label to a product without contacting it with the tamp pad. When a system is equipped with the tamp-blow option, a burst of air will blow from the tamp pad once the programmed tamp duration has expired. The timed length of the burst of air is controlled by programming a value in the “Flag Duration” setting in the Tamp Setup menu. Once the programmed time has expired, the tamp slide will return to the home position.

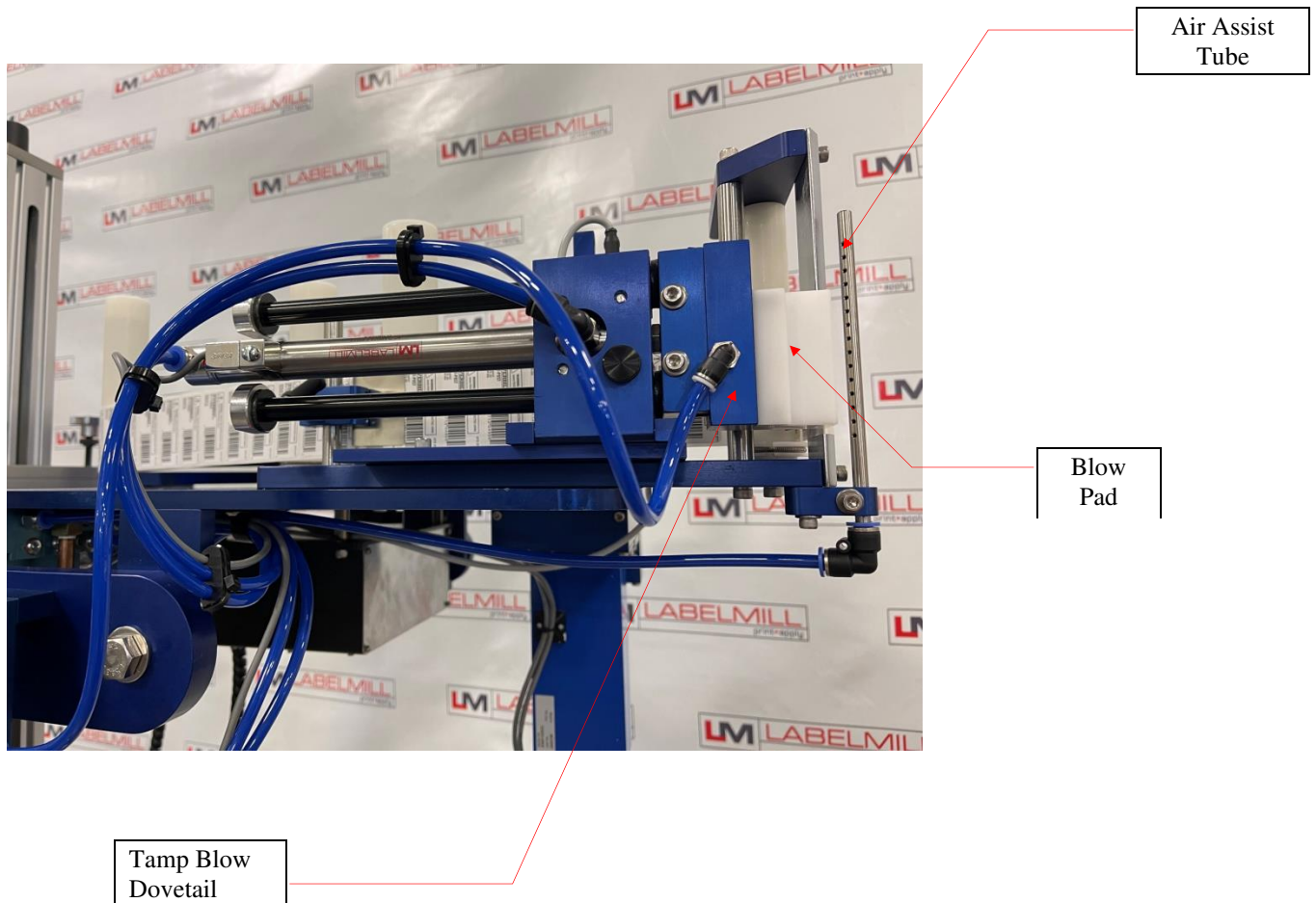

Flag Assembly & Factory Setup

NOTE: PICTURES SHOWN MAY NOT RESEMBLE YOUR MODEL

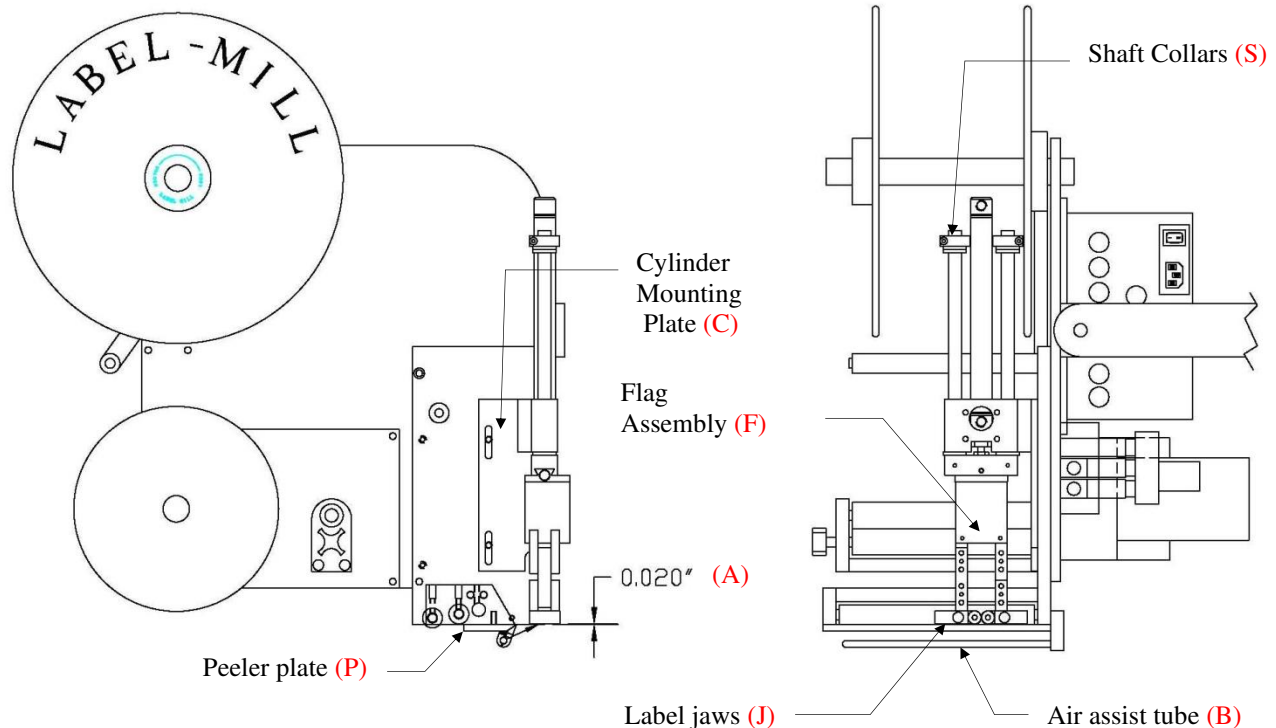

Label jaw to peeler plate clearance and maximum cylinder travel

To adjust the label jaws (J) in relationship to the peeler plate (P), the cylinder mounting plate (C) and the shaft collars (S) must be adjusted accordingly. The cylinder mounting plate (C) is used to adjust the gap between the peeler plate and the label jaws (A). The shaft collars (S), along with the air valves, are used to adjust the label jaws maximum travel.

1. To adjust the label jaws to peeler plate clearance (A), loosen the two button head cap screws and adjust the cylinder mounting plate to reach the desired 0.020" (A) clearance.
2. After this is set, retighten the cap screws. The dimension (A) should now be double-checked to insure proper clearance. This adjustment is very important! If this is not adjusted properly, the label will run into the back of the label jaws (J) and fold or bunch up.

Air assist tube adjustment

1. Adjust the air assist tube (B) so that the small holes aim towards the center of the label as shown by the arrowhead shown above. The air assist tube (B) aids the label to adhere to the bottom of the label jaws (J). Once the label is "blown" onto the label jaws (J), it is held there by vacuum.
2. Once the above adjustments are made, adjust the vacuum regulator, the air assist regulator, and the flow controls.

Note: Too much pressure on the air assist will cause the label to flutter and/or blow off of the vacuum platen.

SECTION 4

PROGRAMMING AND CONTROL OPERATION

DESCRIPTION	PAGE
Hand Held Labeler Interface (HLI-200)	32
Control Accessory Connections	33
Programming	34
System Editor & Programming Menus	35-74
Input & Output Description	75
Logic Board	76-78

HAND HELD LABELER INTERFACE HLI-200

The HLI-200 is a touch screen interface used to display the current system status, clear system faults, and edit the system parameters. The interface cable connects the HLI-200 directly to the system control box and allows for the interface to be removed from the holster mount for easy, remote access to control the applicator system.

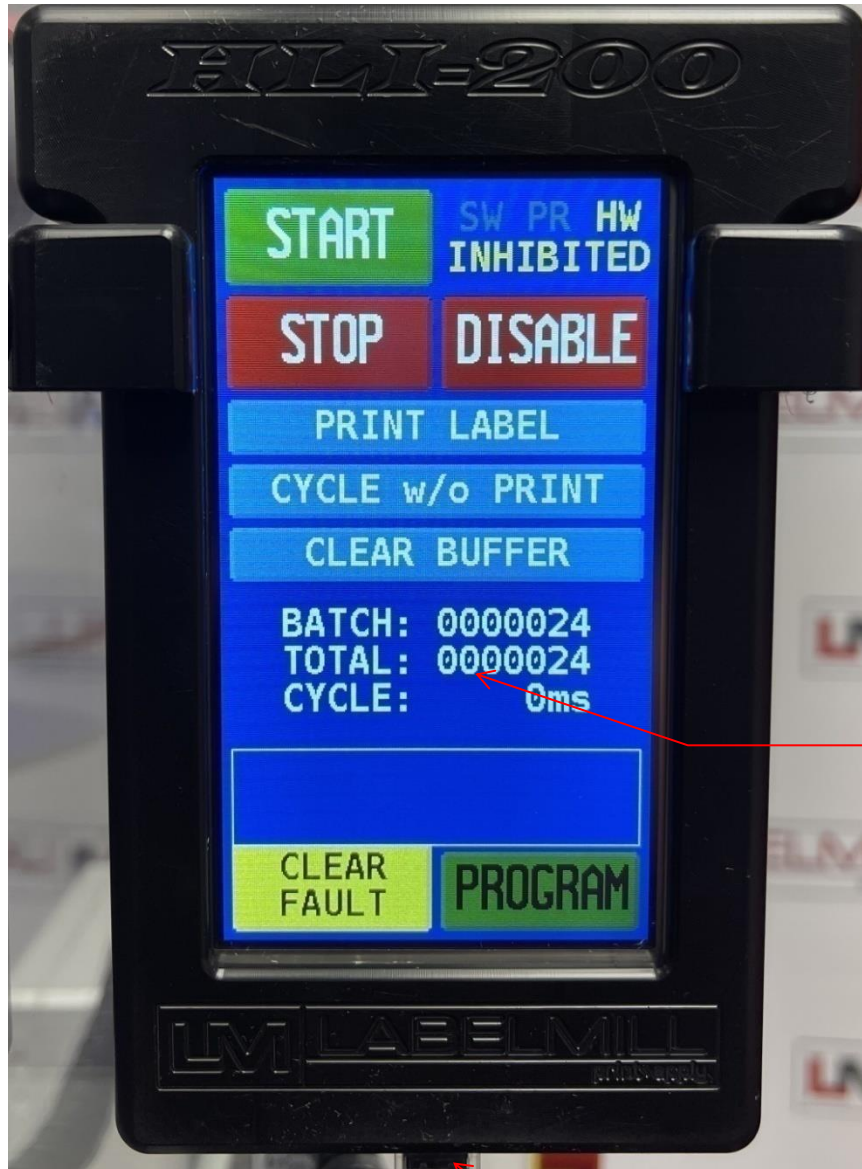

TOUCH-SCREEN
DISPLAY

INTERFACE CABLE

ACCESSORY CONNECTIONS

LOCATED ON BACK OF LABELER CONTROL ENCLOSURE

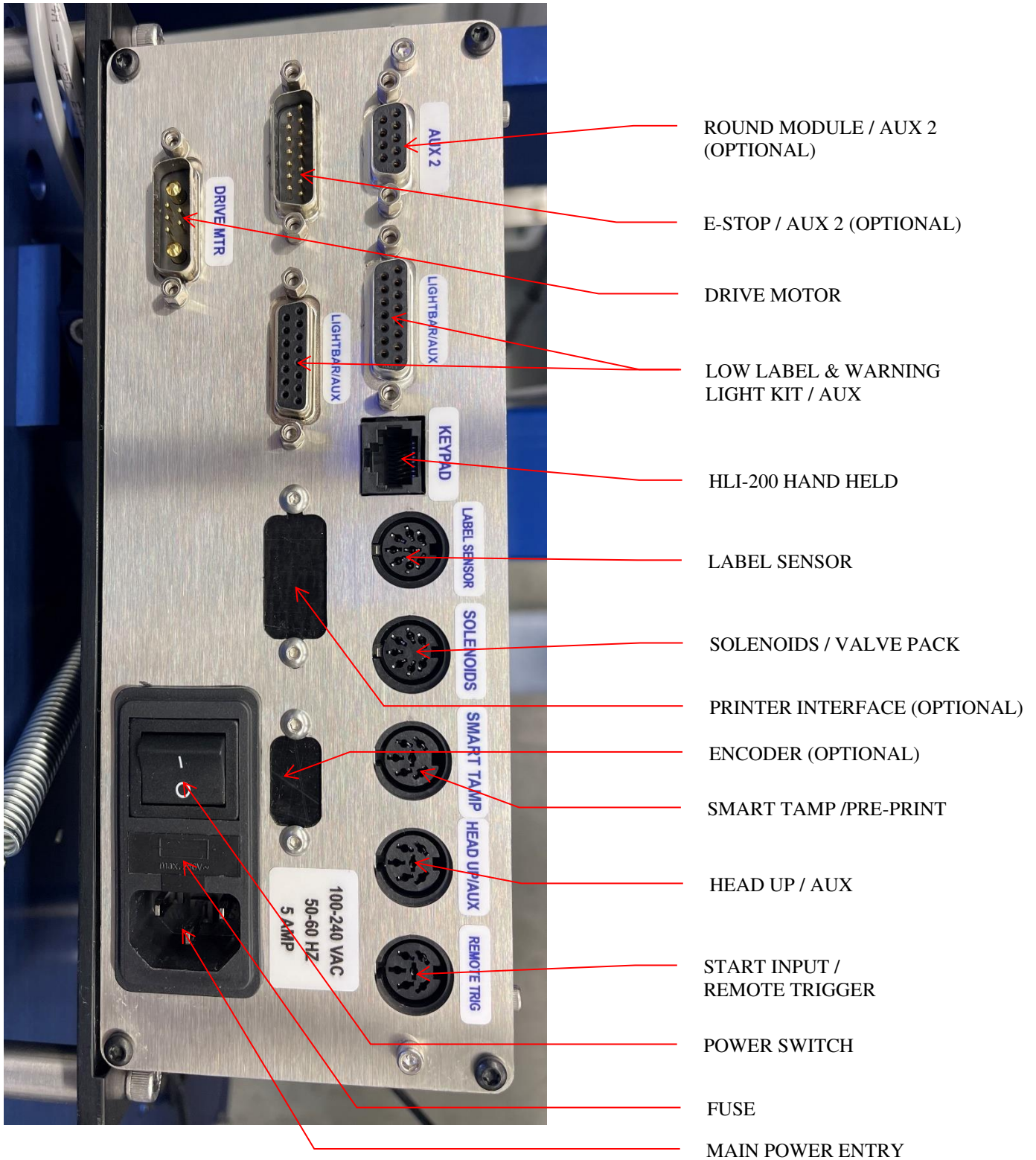

PROGRAMMING

All programming is performed via the **HLI-200** keypad and display. All programmed settings are backed in nonvolatile memory and are not lost when the unit is powered off.

Upon power up of the control, the screen will display *MODEL NUMBER & REVISION* of the HLI-200 and then the *MODEL NUMBER & REVISION* of the labeler control. After this, the screen will now display the "Total" counter, "Batch" counter, and Cycle time in the center of the screen. Error messages or warnings will be displayed in the box at the bottom of the screen. The top of the screen allows you to Start, Stop, Enable, or Disable the system, and also shows the current state of the system.

KEY FUNCTIONS:

START:

Start key will initialize a full application cycle.

STOP:

Stop key will abort the current system cycle.

ENABLE/DISABLE:

Will enable or disable the system. Current system status will be shown in upper right corner.

PRINT LABEL:

Signals an *optional* connected printer to dispense (1) printed label (Files must be loaded into Print Buffer).

CYCLE WITHOUT PRINT:

Will cycle the attached applicator module without signaling an *optional* printer to print a label or faulting the system.

CLEAR BUFFER:

Will clear any trigger signals remaining in buffer.

CLEAR FAULT:

Clear key will clear an error status

PROGRAM:

Program key will enter the system editor.



THE STATUS WINDOW WILL DISPLAY SYSTEM MESSAGES (LOW LABEL, FAULT MESSAGE, ETC)

SYSTEM EDITOR

Press the "Program" button from the main run mode screen to enter the system editor. Here you will find the following options:

I/O Panel - Press to enter I/O Screen

Toggle Outputs - Press to enter the menu to test the individual system outputs

Counters - Press to enter Counters configuration menu.

Job Storage - Press to enter Job Storage menu options.

Show Config - Press to display all of the current programmed system parameters.

Edit Config - Press to enter System Editor Configuration menus.

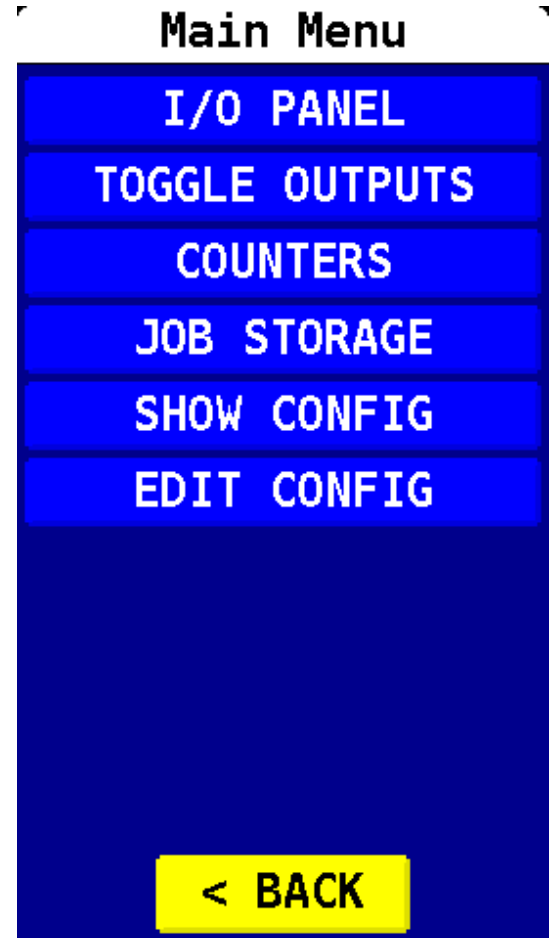

BACK

Use the "BACK" key to save any changes and return to Run Mode main screen.

SYSTEM PROGRAMMING

I/O PANEL

Displays the current status of the system inputs and outputs.

X = On 0 = Off

A “green” character represents a signal that is currently in an “On” state, while a “grey” character represents a signal that is currently in an “Off” state.

I/O Panel

	0	1	2	3	4	5	6	7	
X0	0	X	0	X	0	X	0	X	
X1	X	0	X	0	X	0	X	0	

INPUTS X=on 0=off OUTPUTS

	0	X	0	X	0	X	0	X	Y0
	X	0	X	0	X	0	X	0	Y1

<p><u>INPUT</u></p> <p>TRIGGER #1 TRIGGER #2 HEAD UP SW SMART TAMP SENSE GAP HW INHIBIT PRT ONLINE PRINTING PRINTER ERR LABEL LOW PAPER END RIBBON LOW RIBBON END</p>	<p><u>OUTPUT</u></p> <p>AIR ASST VACUUM TAMP SOL FLAG SOL AUX SLIDE IN CYCLE TAMP SYNC PRT START REPRINT RED LT YELLOW LT</p>
---	---

< BACK
MORE

BACK

Use the "BACK" key to return to the main menu options.

Toggle Outputs

The TOGGLE OUTPUTS menu can be used to manually test the individual system outputs from the HLI-200 input device. Before you can advance to the outputs, the system cycle must be disabled by selecting “YES” on the touch screen.

To test the individual outputs, you can select the numbered output in the left column to turn it on or off (highlighted in green = on). Alternatively, you can select the “PULSE” button in the right-hand column to activate the output for 100ms.

There are two pages of outputs available, which can be selected by pressing the “Y0” or “Y1” tab at the top of the chart.

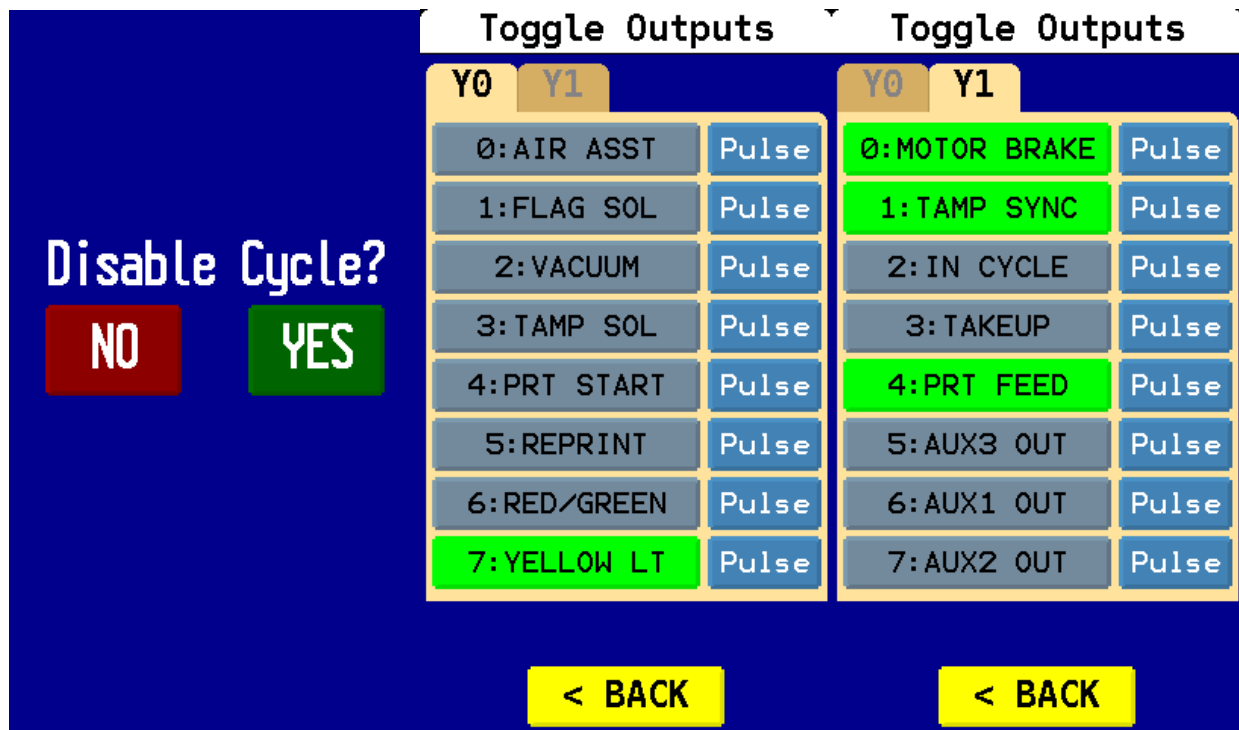

BACK

Use the "BACK" key to return to the main menu options.

COUNTERS

Used to reset the internal counters of the control or set the batch counter parameters.

PROGRAMMABLE BLOCKS:

- BATCH PRESET** - Used to set Batch Counter. Once reached, the applicator will Inhibit.
- CLEAR BATCH CTR** - Used to clear the programmed batch counter.
- CLEAR TOTAL CTR** - Clears the system Total Counter

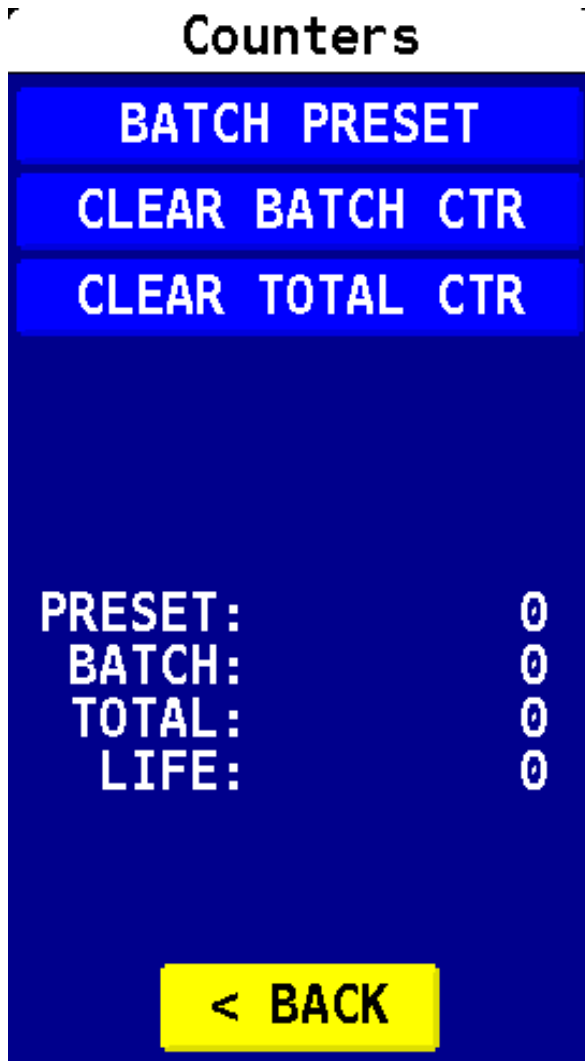

BACK

Use the "BACK" key to return to the main menu options.

JOB STORAGE

Use to store frequently used settings pertaining to different labeling jobs (recipes).
Up to (6) jobs can be stored & recalled.

PROGRAMMABLE BLOCKS:

Load Defaults – Reverts system parameters back to factory defaults

Restore A Job – Recalls settings of a previously saved job.

Save A Job – Stores settings for the active job.

Delete A Job – Deletes a saved job.

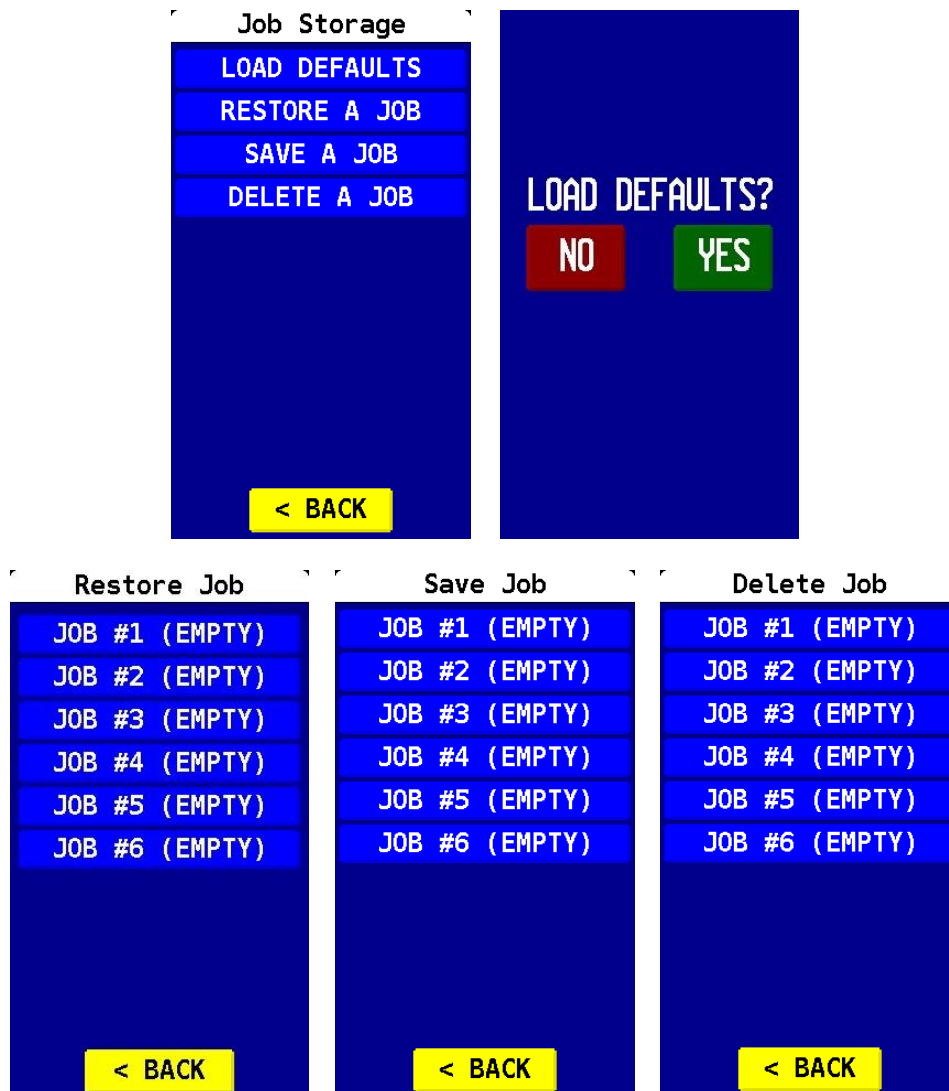

BACK

Use the "BACK" key to return to the main menu options.

SHOW CONFIG

Lists all of the current programmed system parameters.

HLI-200 v3.34!LM4012 v9.99 GEN2-RM

```

0: ADDRESS=1
1: TRIGGER EDGE=leading
2: BATCH PRESET=0
3: MULTIFEED COUNT=1
4: MULTIFEED DELAY=0.1s
5: TAMP DURATION=0.0s
6: FLAG DURATION=0.0s
7: VACUUM RELEASE=0.0s
8: TAMP SYNC LOGIC=normal
10: CYCLE TYPE=feed only
12: ENCODER OVERRIDE=100.0%
13: ENC TRIG DIST=2.0"
14: CONVEYOR ENCODER=off
15: VACUUM ON DELAY=0.0s
20: ON DEBOUNCE=0.0s
21: OFF DEBOUNCE=0.0s
22: LIFE COUNTER=0
23: HEAD UP DEBOUNCE=0.0s
24: ENCODER LPI=100.0 LPI
25: BATCH COUNT=0
26: TOTAL COUNT=0
27: PRT RDY TIMEOUT=5.0s
28: PRODUCT DELAY=0.0s
29: HEAD UP SW TYPE=none
30: LABEL FEED DLY=0.1s
31: ROLLER STOP DLY=0.5s
32: ROLLER SPEED=100 IPM
33: ROLLER ACC/DEC=50000
34: DISTANCE 0-2nd=0.0"
35: DISTANCE 0-3rd=0.0"
36: DISTANCE 0-4th=0.0"
37: DISTANCE 0-5th=0.0"
38: DISTANCE 0-6th=0.0"
39: DISTANCE 0-7th=0.0"
40: DISTANCE 0-8th=0.0"
41: DISTANCE 0-9th=0.0"

```

Page 1, tap for next page.

HLI-200 v3.34!LM4012 v9.99 GEN2-RM

```

42: DISTANCE 0-10th=0.0"
45: LABEL LENGTH=1.0"
46: LABEL GAP LENGTH=0.125"
47: LABEL STOP POSN=0.0"
49: MISSED LABEL DET=off
50: LABELS TO PEELER=0
51: MISSING LBL COMP=off
54: MAX CONV SPEED=1600 IPM
55: LABEL SPEED=100 IPM
57: REQUIRE PASSWORD=disabled
58: LABEL ACCEL=100%
59: CONVEYOR SPEED=1500 IPM
60: CONVEYOR DIST=0.0"
63: ALARMS={none set}
64: MOTOR DIRECTION=right-hand
66: PRINTER OPTIONS={none set}
69: TRIGGER MODE=product delay

```

Page 2, tap to exit.

CONFIGURATION MENU

The Configuration Menu is used to enter the programmable system parameters. Any changes made the system parameters will take effect immediately, allowing an operator to “dial in” the system for the current application. Once all parameters have been adjusted, the operator must either press the “Save” button to save the settings memory, or the “Cancel” button to revert to the previously saved settings. Pressing either button will return the operator to the main menu.

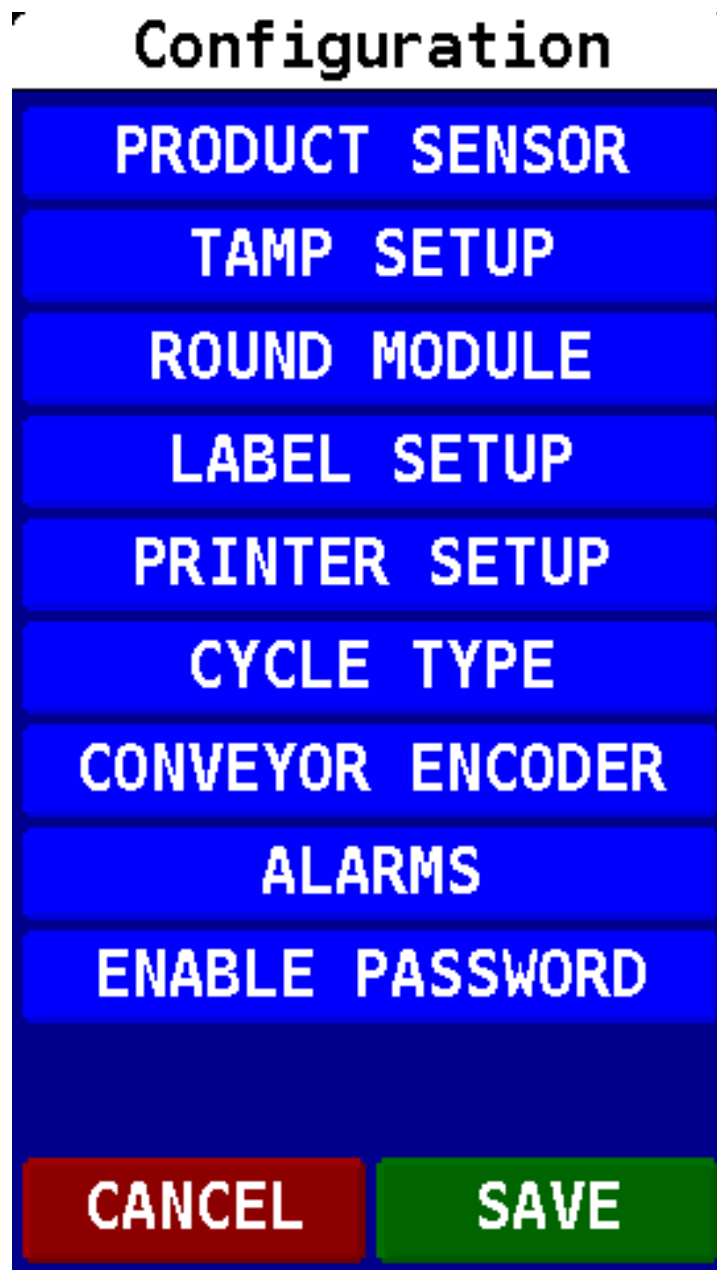

PRODUCT SENSOR MENU

A Product Sensor is an external device that when “activated” starts the application cycle. Most label applicator systems are provided with an external device (i.e., photo eye) or a trigger cable.

PROGRAMMABLE BLOCKS:

- **Product Delay** - Delays the cycle start (x) seconds after the sensor has been activated.
- **Trigger Edge** - Designates whether product sensor is activated at the leading or trailing edge of trigger input signal.
- **Trigger On Debounce** - Programmable timer that a trigger signal must be actively “on” for a start cycle to activate.
- **Trigger Off Debounce** - Programmable time that input triggers will be ignored for after a completed cycle.
- **Multi-Feed Count** - Programs how many labels are applied to one product with one signal.
- **Multi-Feed List** - Current programmed parameters for multi-feed delay settings.
- **Multi-Feed Delay** - Programmable delay between each programmed multiple feed.

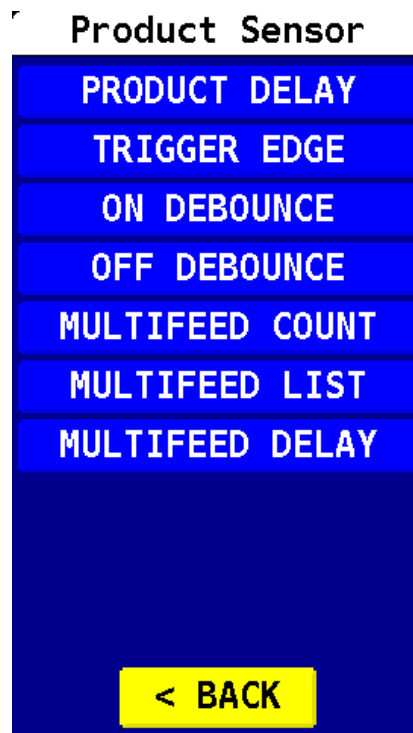

BACK

Use the "BACK" key to return to the main menu options.

PRODUCT DELAY

Delays the cycle start (x) seconds after the sensor has been activated. When programmed, the system will delay the start of the application cycle until the programmed Product Delay timer has expired. This feature is used to adjust the placement of the label on a moving product.

To program a value, use the numeric keypad to enter the desired value, and then press the enter key. The escape key will revert to the previous menu without changing the currently programmed parameter.

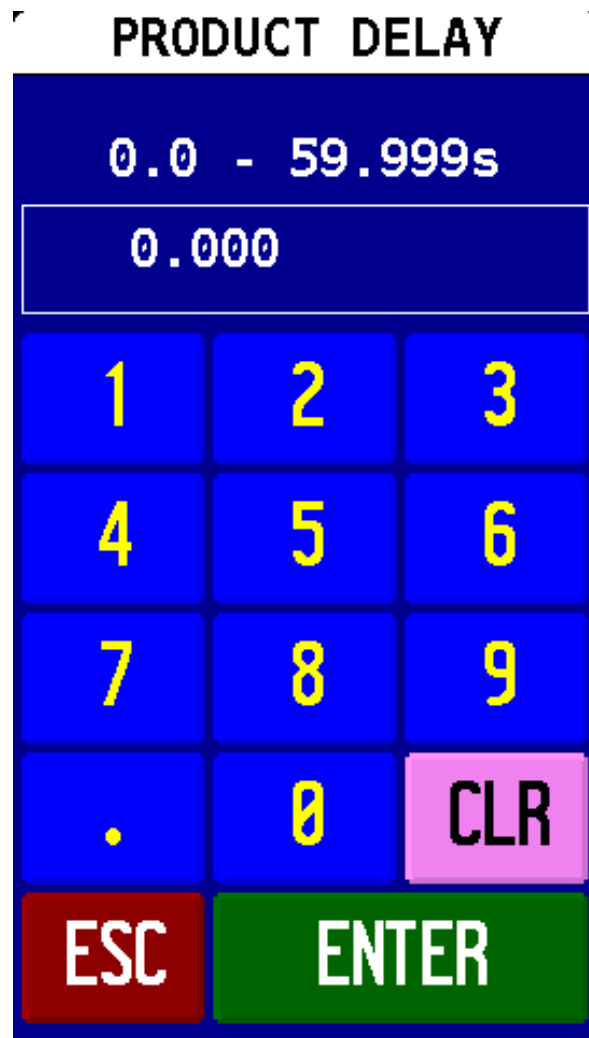

TRIGGER EDGE

Designates whether the product sensor is activated at the leading or trailing edge of trigger input signal. When set to “Leading” the application cycle (beginning with the programmed product delay) will start when a trigger input is received. When set to “Trailing” the application cycle will start only after a trigger is received (“ON”), and has then been removed (“OFF”). While most applications will trigger from the leading edge of a product, the trailing edge can be very useful for applying labels consistently to larger products without programming a large product delay. For example, when using an external photoeye trigger to place a label on the trailing edge of a carton traveling down a conveyor, using the trailing edge parameter will use the photoeye to signal the system that the carton is present, but will not send the trigger input to the system until the carton is no longer seen by the photoeye. The lowest possible value should be programmed into the Product Delay for label placement accuracy and consistency.

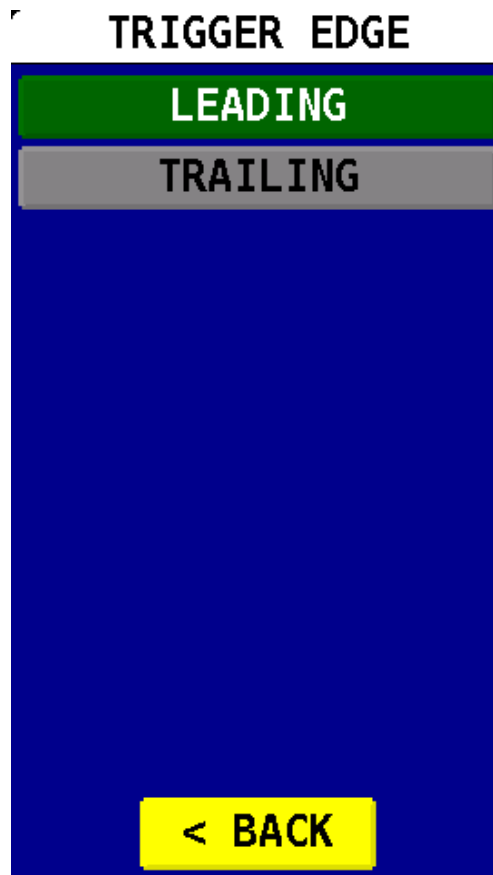

BACK

Use the "BACK" key to return to the main menu options.

ON DEBOUNCE

Programmable timer that a trigger signal must be held “On” for a start cycle to activate. This feature is used to filter out erratic trigger signals that may occur from other factors (electronic noise, reflective vests, etc.)

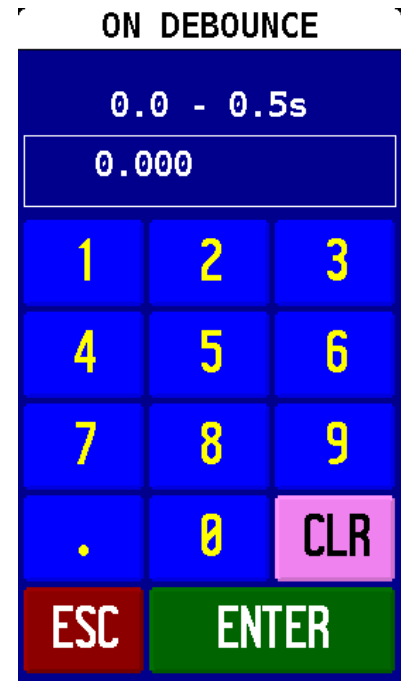

OFF DEBOUNCE

Programmable time that input triggers will be ignored for after a completed cycle. This feature is used to filter out erratic trigger signals that may occur immediately after an application cycle has finished. The Off Debounce timer will become active after an application cycle has finished, and can be used to ensure that another application cycle cannot be started until the programmed Off Debounce timer has expired.

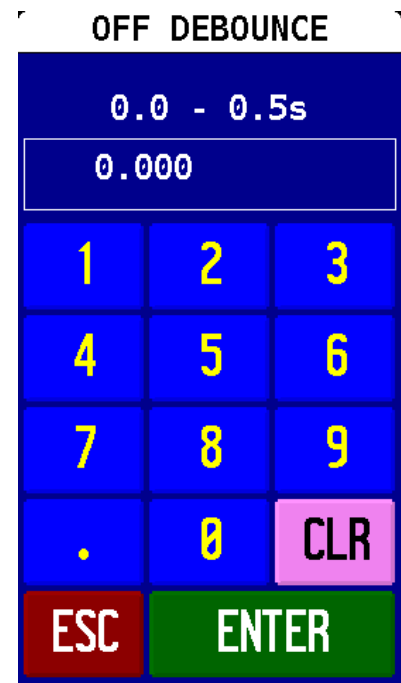

MULTI-FEED COUNT

Programs how many labels are applied to one product with one trigger signal. When disabled, a single label will be applied with each trigger signal.

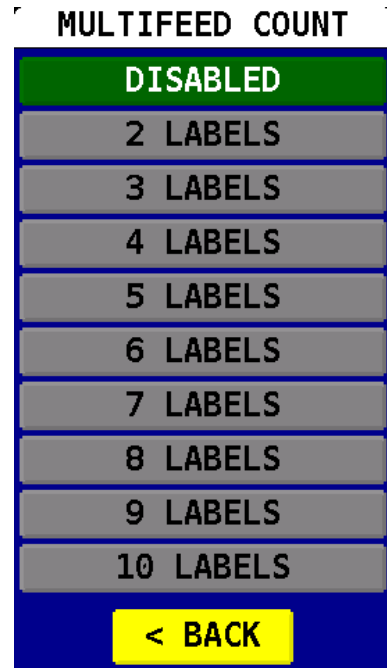

MULTI-FEED LIST (External Encoder)

Programmable parameters for multi-feed delay settings only when used in conjunction with an external encoder. The Conveyor Encoder feature must be turned on and Programmed to be used with the Multifeed List feature.

This feature is used to apply labels at specific distances from the initial trigger signal. An external encoder must be properly configured to apply the labels accurately.

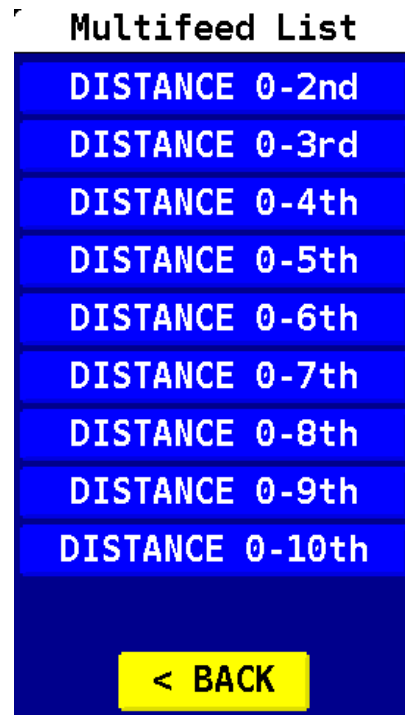

BACK

Use the "BACK" key to return to the main menu options.

MULTI-FEED DELAY

Programmable timed delay between each programmed multiple feed. This feature is used to control the delay between the first label application and subsequent label applications. The delay of the application of the first label is still programmed through the Product Delay in the Product Sensor menu, but the additional cycles selected in the Multifeed Count will be delayed with by the Multifeed Delay timer. The Multifeed delay will be active when an external encoder is not used, and the Conveyor Encoder feature is turned off.

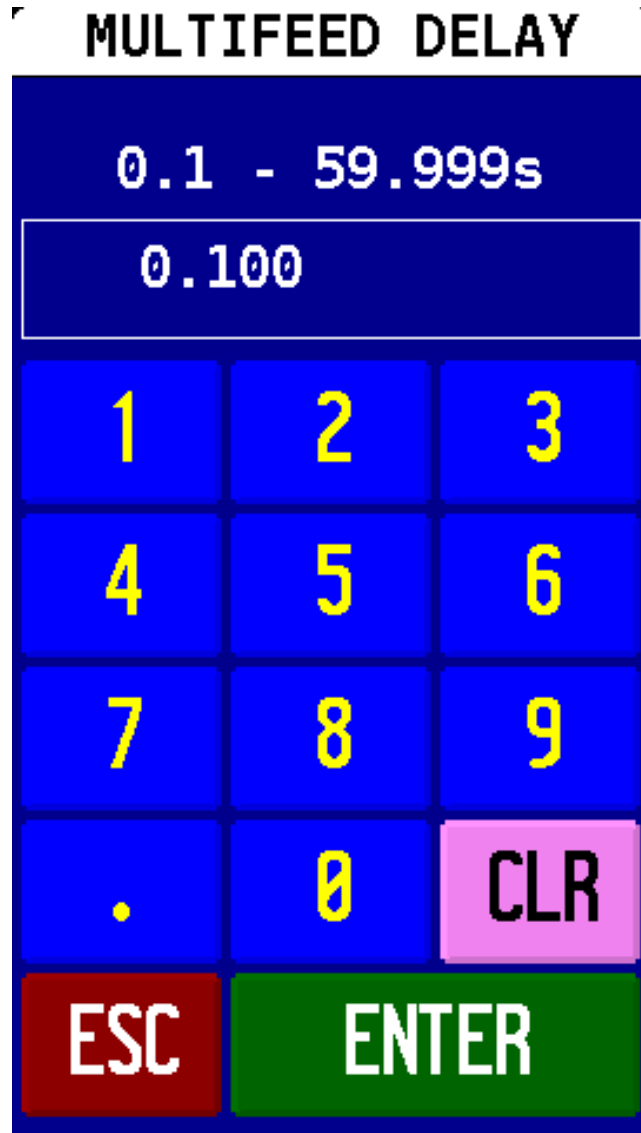

TAMP SETUP

Tamp Setup is used to adjust the various parameters related to a pneumatic “tamp” cycle type.

PROGRAMMABLE BLOCKS:

- **Tamp Duration** - Used to adjust the time that the tamp cylinder valve is actuated.
- **Flag Duration** - Used to adjust the time the flag jaws are held open after label application.
- **Head Up SW Type** - type: *normally open* (Default), none
- **Head Up Debounce** - Used to allow time for the tamp cylinder to settle on return.
- **Vacuum Release** - Used to release the label when tamping on light products.
- **Vacuum On Delay** - Used to reduce label flutter when feeding large labels onto the platen.
- **Tamp Sync Logic** - Used to reverse tamp sync outputs.

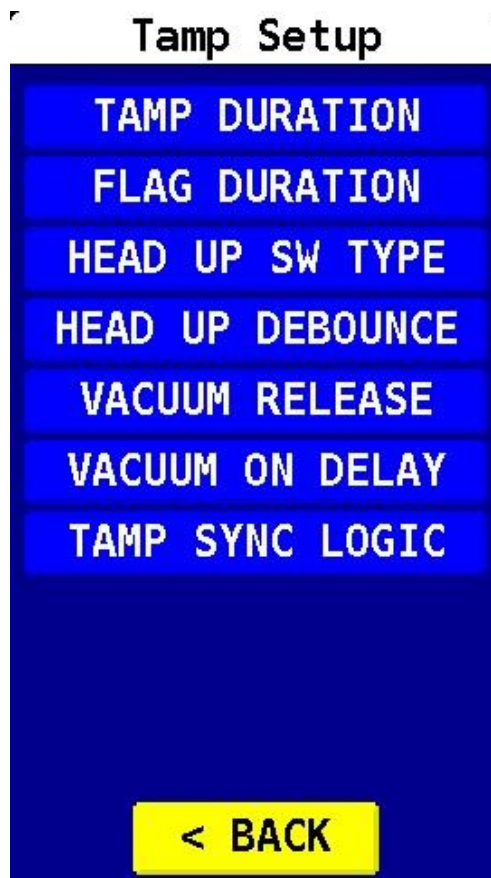

BACK

Use the "BACK" key to return to the main menu options.

TAMP DURATION

Programmable value in seconds used to adjust the time that the tamp cylinder valve is actuated. The tamp duration will become active after the programmed Product Delay has expired. Once the Tamp Duration value has expired, the applicator module will return to the “home” position.

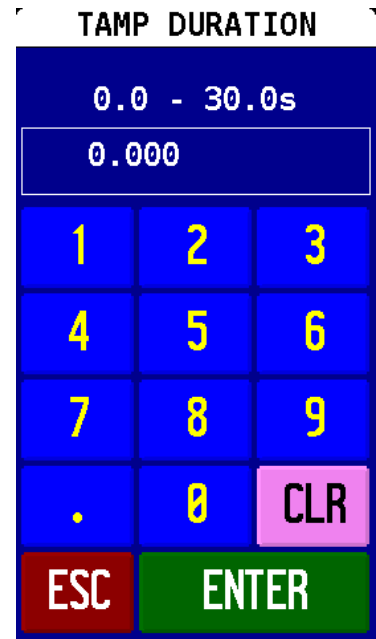

FLAG DURATION

Programmable value in seconds used to adjust the time the flag jaws are held open after label application (when equipped with a flag label applicator module). This allows the flag jaws to be held open to return the applicator module to the home position without contacting the product that has just been labeled. The flag duration timer will activate after the programmed tamp duration timer has expired.

The Flag Duration timer is also used in conjunction with the optional tamp-blow module or blow-on module. In these cases, the flag duration time is used to activate and adjust the time that the blow valve is activated.



HEAD UP SWITCH TYPE

The Head Up Switch Type menu is used in conjunction with various applicator modules to tell the applicator system whether or not the applicator module is in the “home” position. For example, a tamp module is equipped with a reed switch at the top of the tamp cylinder that is “on” when the tamp head is “up” (home).

N.O. (normally open) is the default value, and should only be changed to “NONE” when an applicator module without a head up switch is used. This setting is critical for the correct operation of a tamp or swing tamp application to ensure the label feed timing is correct.

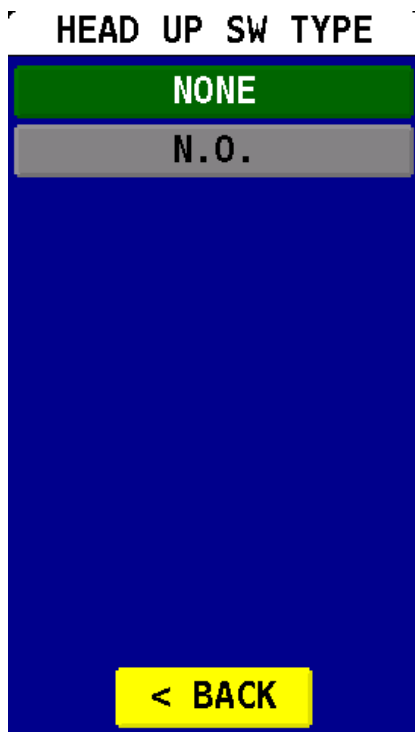

BACK

Use the "BACK" key to return to the main menu options.

HEAD UP DEBOUNCE

Used to allow time for the tamp cylinder to settle on return. This setting will delay the feed of the label onto the vacuum platen upon the return of the applicator module to the home position. Larger label application modules or high-speed applications may require adding a head-up debounce for label feed consistency.

For example, when running a pneumatic tamp applicator system in a Tamp Before Feed cycle type, a label will be fed out and onto to the vacuum platen once the head-up switch is activated after the return of the tamp cylinder to the home position. If the physical switch is incorrectly adjusted or the cylinder returns home very quickly, the tamp pad may not be home and stable when the label feed begins to occur.

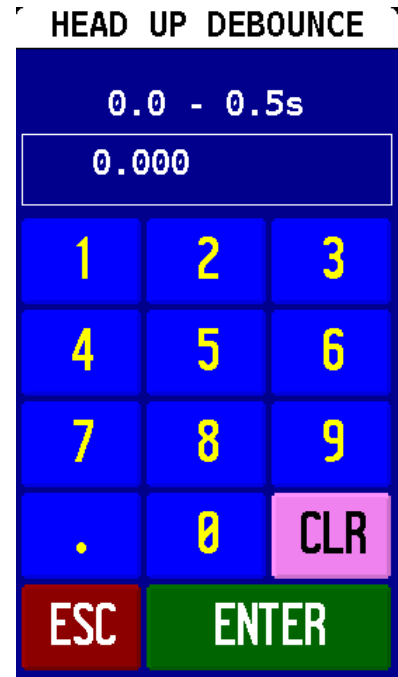

VACUUM RELEASE

When tamping on light products or using media that is susceptible to static cling, this feature can be used to release label from the vacuum platen by turning off the vacuum duration the label application mid-cycle.

The vacuum release is a timer that counts backwards from the end of the programmed tamp duration, and turns the vacuum off when the programmed Vacuum Release expires. For example, if setting a Tamp Duration to 2.0 seconds and a vacuum release to 0.5 seconds, the vacuum on the tamp pad will be turned off 1.5 seconds after the tamp motion begins. The vacuum release is typically set to zero, and only used when experience problems getting the label to release from the vacuum platen.

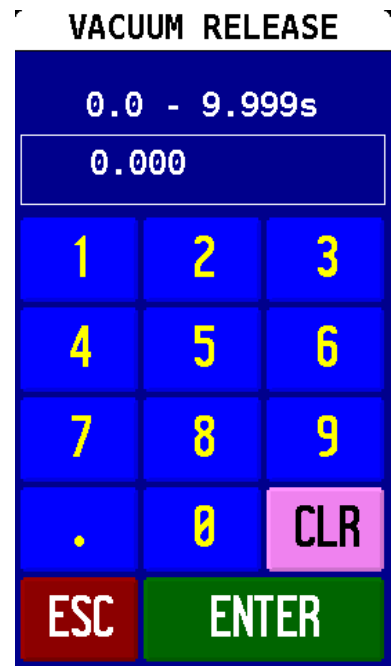

VACUUM ON DELAY

The Vacuum On Delay is a programmable timer that prevents the vacuum from turning on when a label feed is activated. Once the timer expires the vacuum will activate.

This feature is commonly used when feeding a larger label onto a vacuum platen. Programming a vacuum delay will assist in reducing flutter, which can result in reduced feed consistency and label placement accuracy.



TAMP SYNC LOGIC

Used for "Normal" or "Reverse" Tamp signal operation and signal transmission. "Normal" operation is the default, and is used in most applications. "Reverse" is typically only used with customized applicator modules.

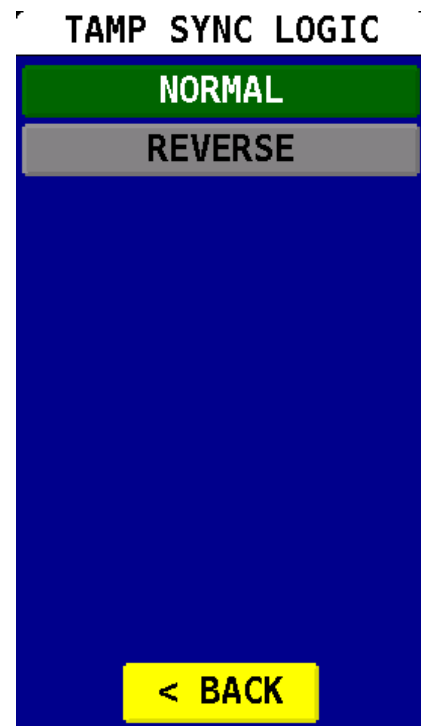

ROUND MODULE SETUP

Used to adjust the system parameters when using the Round Module attachment.

PROGRAMMABLE BLOCKS:

- **Roller Stop DLY** - Used to adjust how long the carriage is lifted and the yellow rollers continue to spin after the end of the label feed is detected.
- **Label Feed DLY** - Used to delay the feed of the label
- **Roller Speed** - Used to adjust the rotation speed of the Round Module (Yellow Rollers).
- **Roller ACC/DEC** - Used to adjust the “ramp up” speed of the round module motor.

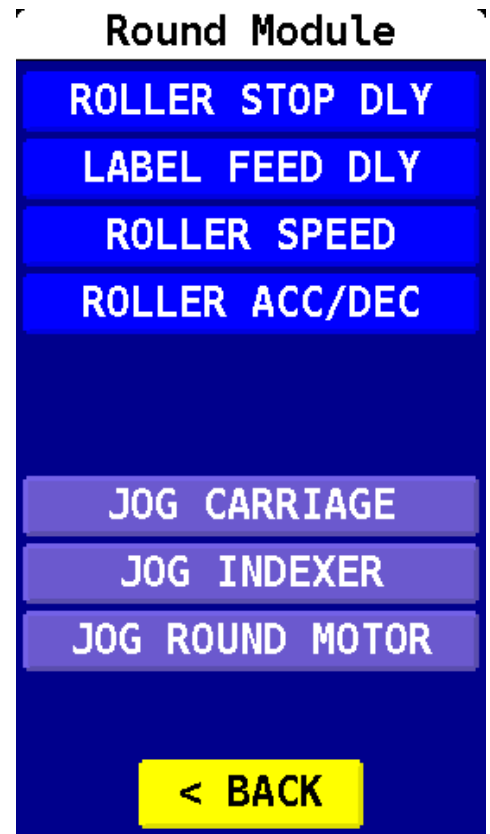

Jog Carriage - Used to manually activate the carriage lift.

Jog Indexer - Used to manually jog an optional indexer (An indexer is not included in standard configurations)

Jog Round Motor - Used to manually spin the yellow drive rollers.

BACK

Use the "BACK" key to return to the main menu options.

ROLLER STOP DLY

The Roller Stop Delay is used to adjust how long the carriage is lifted and the yellow rollers continue to spin after the end of the label feed is detected. In some applications, additional rotations may be required to fully adhere the label to the product.

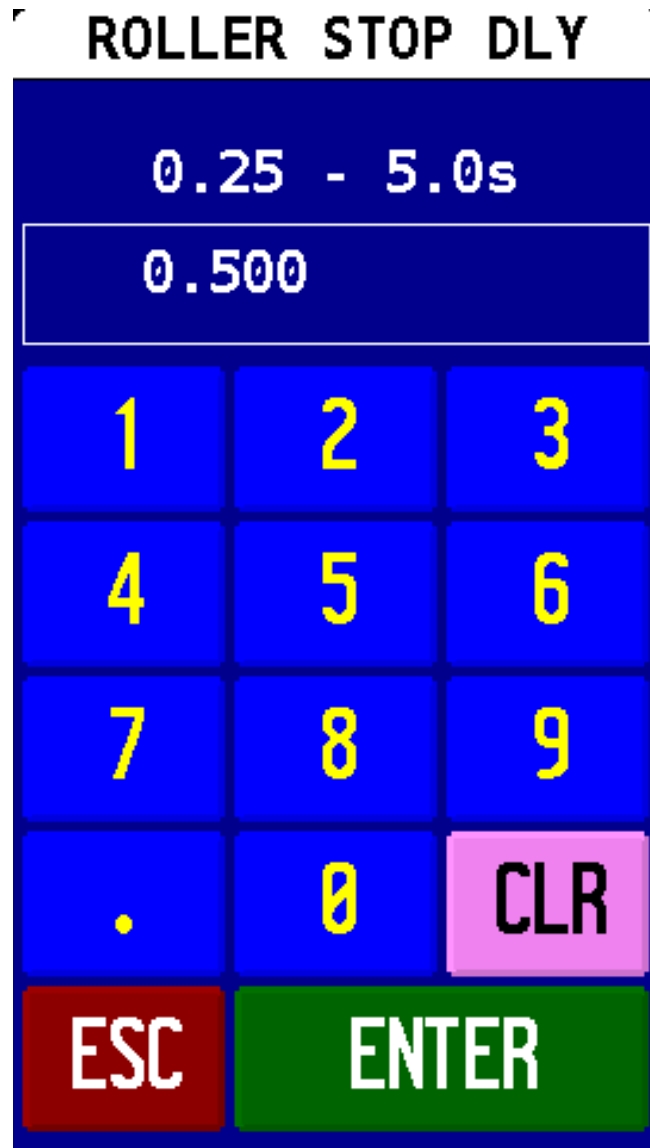

LABEL FEED DLY

The Label Feed Delay is used to delay the feed of the label after the carriage has lifted the product to the yellow rollers. This will allow the product to stabilize before the label is fed and applied to the product.

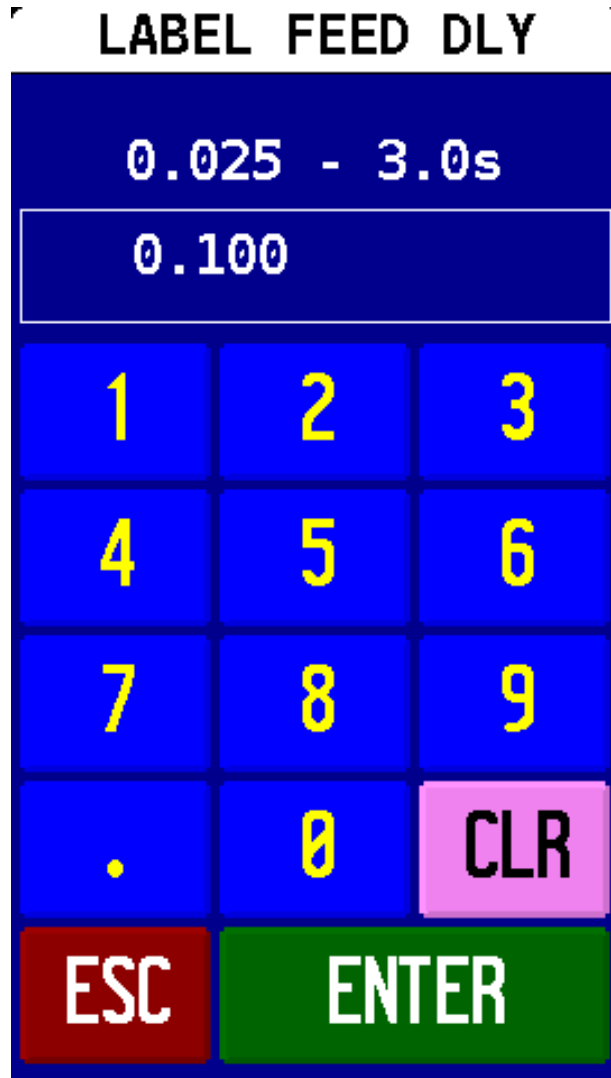

ROLLER SPEED

The Roller Speed menu is used to adjust the rotation speed of the Round Module (Yellow Rollers). The Roller Speed typically needs to match the programmed Label Speed in the Label Setup menu to apply the label correctly and consistently.

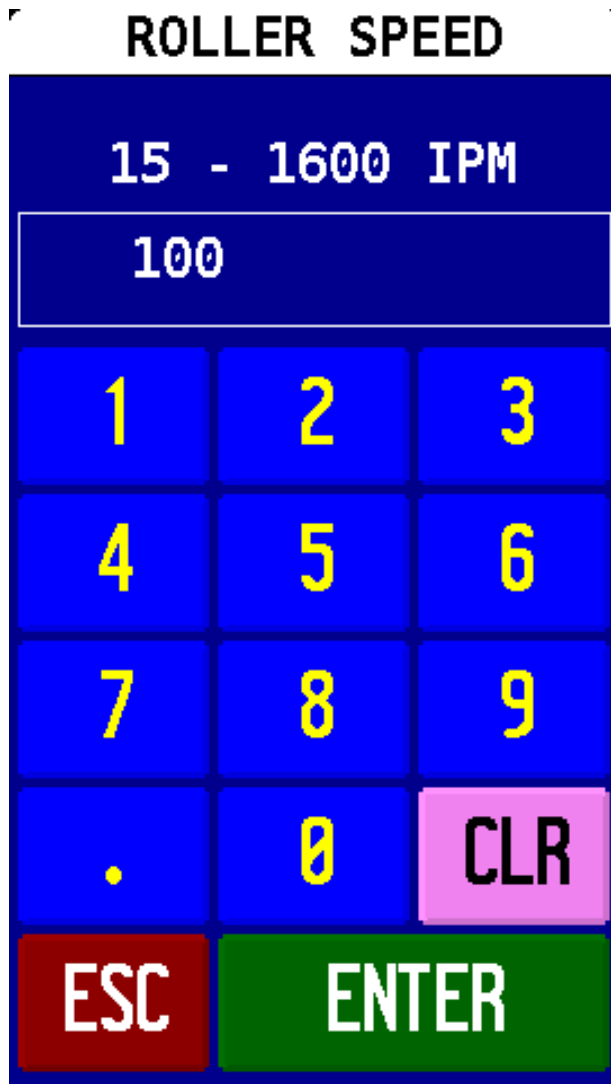

ROLLER ACC/DEC

The Roller Acceleration / Deceleration is used to adjust the yellow roller “ramp up”& “ramp down” speed of the round module motor. This is set to 50,000 by default and should only be adjusted for high-speed applications.

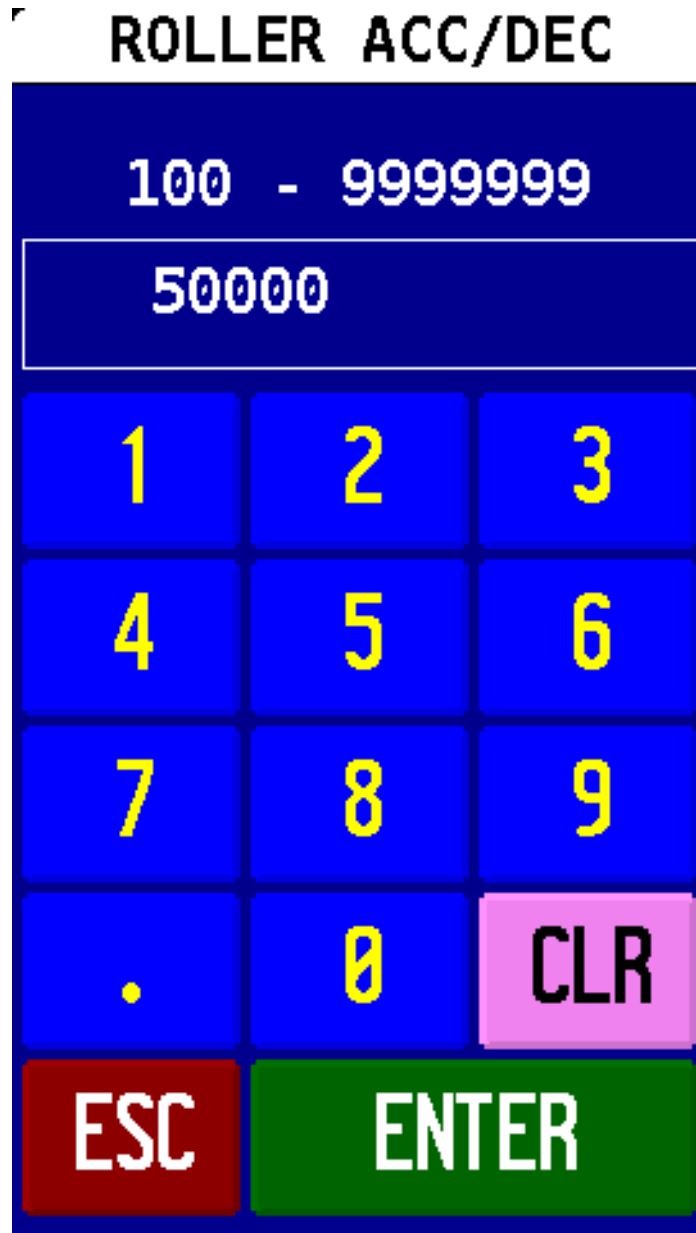

LABEL SETUP

The Label Setup menu is used to adjust the parameters of the label feed as well as the settings for the label size that is currently in use.

PROGRAMMABLE BLOCKS:

- **Label Speed** - Controls the feed speed of the label.
- **Label Accel** - Controls the acceleration of the motor.
- **Motor Direction** - Controls the direction of the motor.
- **Label Length** - Programmable length of the label.
- **Label Gap Length** - Programmable gap between labels.
- **Label Stop Posn** - Electronically adjusts label stop position in reference to the peeler plate point.
- **Missed Label Det** - Turns on the missing label alarms and enables the auto advance feature (optional feature only).
- **Labels To Peeler** - Used to program number of labels from label sensor to peeler point.
- **Missing LBL Comp** - Used to automatically advance the web to compensate for a missing label (optional feature only).

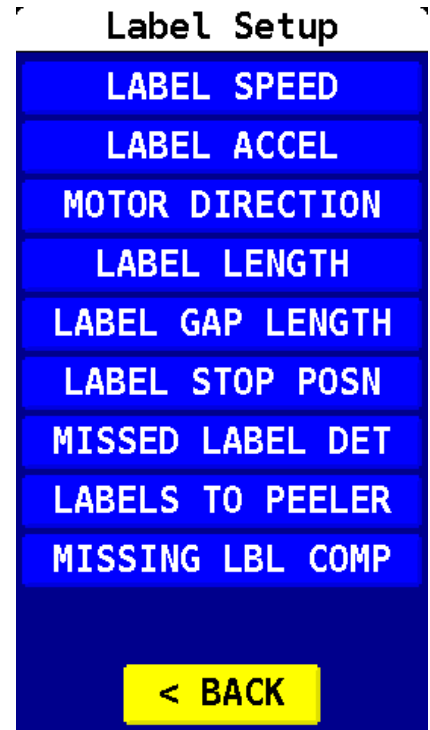

BACK

Use the "BACK" key to return to the main menu options.

LABEL SPEED

The Label Speed menu is used to control the feed speed of the label. In a synchronous feed (wipe-on) application, the label speed must match to speed of the conveyed product. Adjusting the Label Speed may result in a different stop position of the label, due to acceleration and deceleration. The Label Speed value is programmed in inches per minute.

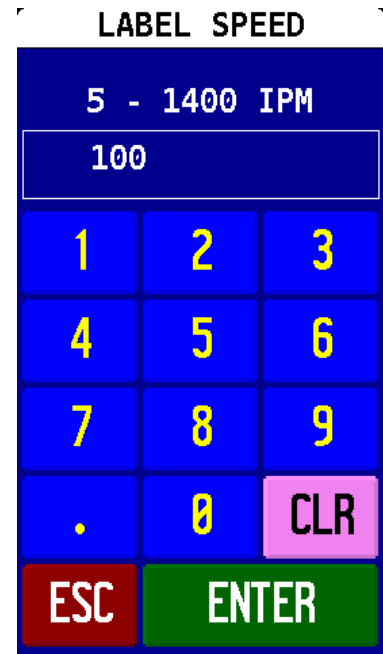

LABEL ACCELERATION

The Label Acceleration is used to control the acceleration of the motor from a stopped position. The default setting is 20%, and should not be adjusted without first consulting a factory trained technician.

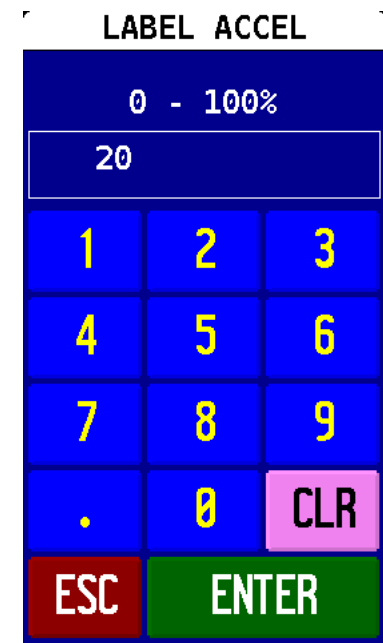

MOTOR DIRECTION

Controls the wind direction of the motor.



LABEL LENGTH

The Label Length is a programmable value, used to match the minimum length of the label that is being used. If the value is set too low, a broken web fault may occur. The Label Length value is programmed in inches.

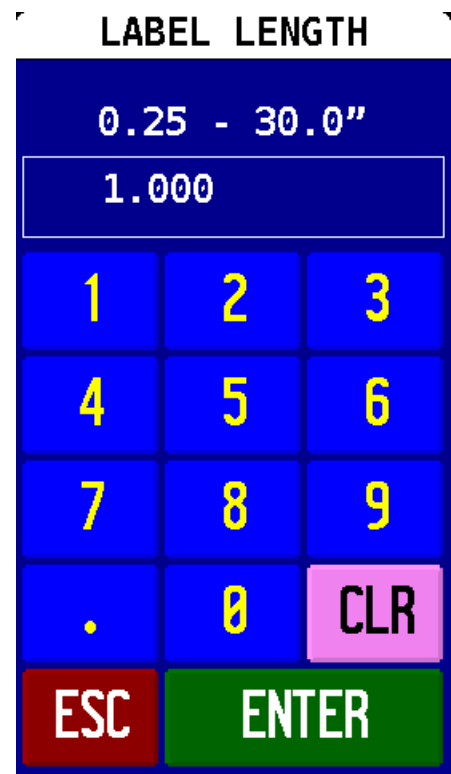

LABEL GAP LENGTH

The Label Gap Length is a programmable value, used to match the minimum length of the gap between labels for the label stock that is being used. If the value is set too low, a broken web fault may occur. The Label Gap Length value is programmed in inches.

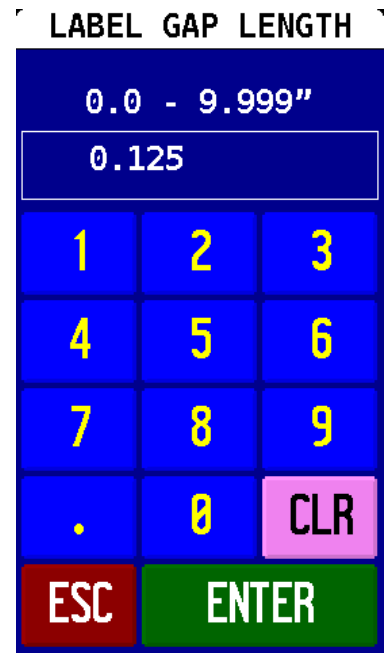

LABEL STOP POSITION

The Label Stop Position is used to electronically adjust label stop position in reference to the peeler plate point. When a value of zero is programmed, the label will stop feeding when the label sensor reaches a gap between the labels. When a Label Stop Position value is programmed, the label will continue to feed the programmed length after the label sensor senses a gap between the labels. This value cannot be more than 50% of the length of the label being used. The Label Stop Position value is programmed in inches.

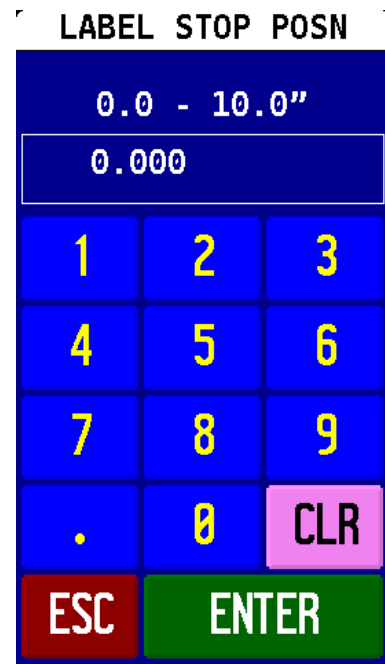

MISSED LABEL DET

The Missing Label Detection menu is used to turn on the missing label alarm by enabling the auto advance feature (used to automatically advance the web when a label is missing on the web, without generating a fault). This option can only be used in conjunction with additional, optional hardware.

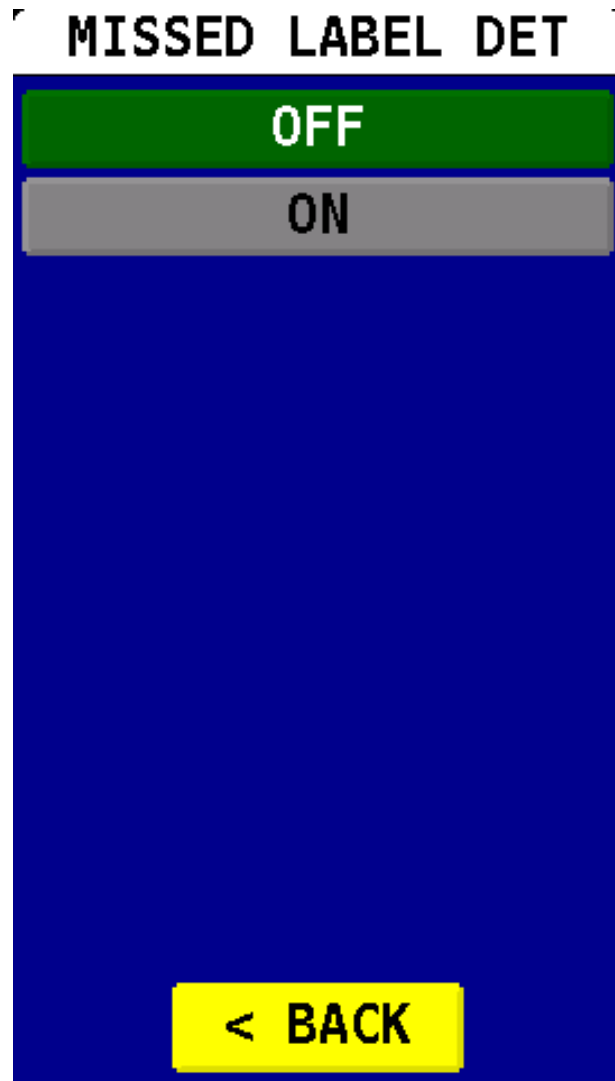

BACK

Use the "BACK" key to return to the main menu options.

LABELS TO PEELER

The Labels To Peeler menu option is used to program the number of labels from the label sensor to the peel point. The setting is only used in conjunction with the Missing Label Detection option, which requires additional hardware. The value should be programmed to match the number of labels between the label sensor and peel point.

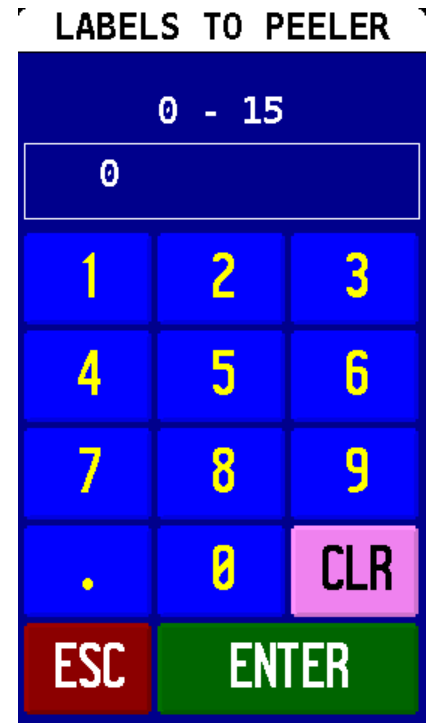

MISSING LABEL COMP

The Missing Label Compensation menu option is used to automatically advance the web to compensate for a missing label. The setting is only used in conjunction with the Missing Label Detection option, which requires additional hardware.

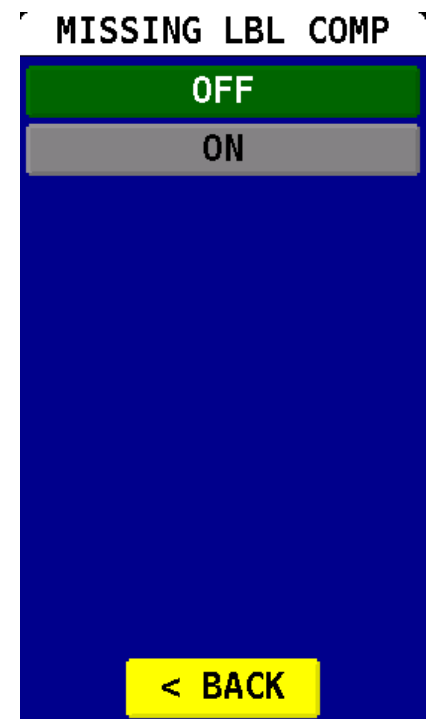

BACK

Use the "BACK" key to return to the main menu options.

Printer Setup

The Printer Setup menu is used to control the system operation when connected to an optional, loose-looped printer.

- **Enable Printer** - Must be active when connected to a printer. This will program the main control to send print triggers to the connected printer, and will also activate additional I/O used with a printer.
- **Ignore Print End** - When active the main control will not require an End of Print signal to be received after each print cycle.
- **Use Print Ready** - When active, the system may inhibit or fault when a connected printer is not in a ready state.
- **Use Repeat Print** - When active, the main control will signal a connected printer to re-print the last remaining label in the print buffer. Additional printer setup may be required.
- **Invert Low Ribbon** - Inverts the signal received from a connected printer for when the ribbon roll is low. This may change depending on the printer that is connected.
- **Print Buffer Inhibit** - When active, the system may inhibit when a connected printer does not have data in the buffer.
- **Feed Blank Labels** - When active, the system will send a Feed signal to a connected printer instead of a Print signal, results in the feed of a blank label. This option is useful when testing or setting up an application, but there is not an option to load data into the print buffer. This option must be deactivated to return to normal operation.



BACK

Use the "BACK" key to return to the main menu options.

CYCLE TYPE

The Cycle Type menu needs to be programmed for the applicator module in use.

Available Cycle Types

- **Feed Only**
 - Synchronous Feed / Wipe-On
- **Tamp Before Label Feed**
 - Activates a pneumatic tamp module to apply a label, return home, and then feed another label onto the platen.
- **Tamp After Label Feed**
 - Activates a feed onto the label platen, and then the pneumatic tamp module.
- **Blow On Before Label Feed**
 - Activates the blow valve, and then another label feed.
- **Blow On After Label Feed**
 - Activates the label feed before the blow valve.
- **Clam Shell Module Before Feed**
 - Activates the pneumatic tamp and clamshell valves before returning home and feeding another label.
- **Clam Shell Module After Feed**
 - Activates the label feed before the pneumatic tamp and clamshell valves.
- **Round Module**
 - Programs the system to activate the connected hardware and signals when the optional Round Module is installed.
- **Auto-Round**
 - Programs the system to activate the connected hardware and signals when the optional Auto Round Module is installed

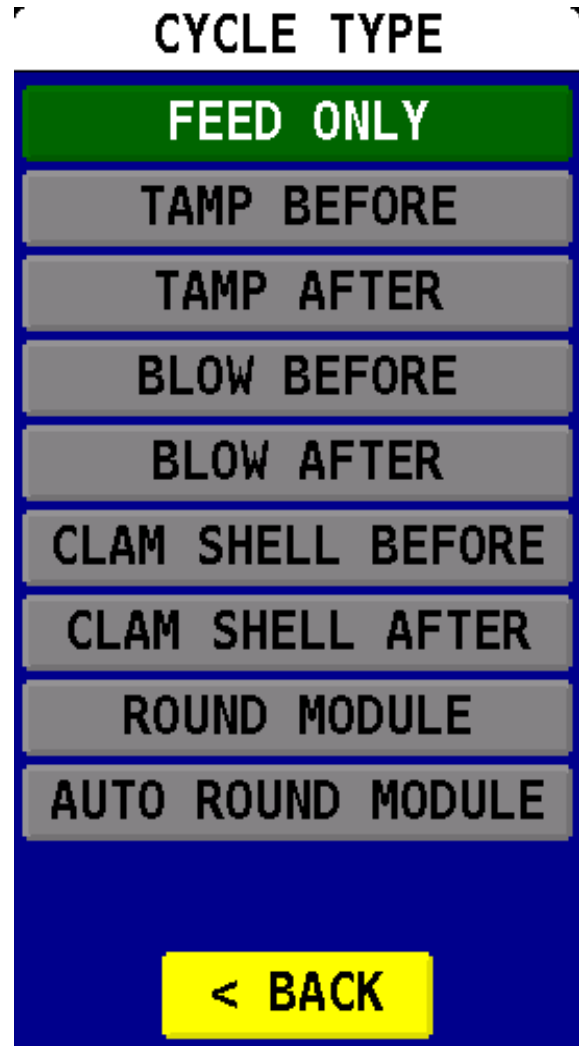

CONVEYOR ENCODER

Provides a more consistent way to apply labels to a product. With this option, a precise distance from the trigger point can be set at which the label is to be applied. Note: an optional external encoder must be used with this feature.

KEY DEFINITIONS

- **ASYNCHRONOUS OPERATION** – The term “ASYNCHRONOUS OPERATION” is used because the speed of the applicator motor (label speed) does not necessarily match the speed of the product conveyor. In other words their speeds are set independently of one another and have NO interrelation. An example of this is when the applicator is configured in the tamp mode.
- **SYNCHRONOUS OPERATION** – The term “SYNCHRONOUS OPERATION” is used because the speed of the applicator motor (label speed) is matched to the speed of the product conveyor. In order to accomplish this, an encoder is used to monitor the speed and distance the product conveyor travels. In order for this feature to function the “CONVEYOR LOCK” mode must be turned on. In synchronous operation, the applicator motor is ELECTRONICALLY GEARED to the product conveyor.
- **ELECTRONIC GEARING** – Electronic gearing is a function of the product encoder and the LabelMill control. This is used to match the speed of the applicator to the product conveyor. Electronic gearing is similar to mechanical gearing in that there is a gear ratio and the change of speed of one affects the speed of the other. This feature is part of the Synchronous feed mode. In order for this to operate properly, the correct number of lines per inch of product travel must be entered into the ENC LINES/INCH in ENCODER LPI screen.
- **ENCODER** – An ENCODER is a device that is used to monitor the speed of an external device like a product conveyor. The reason this speed is monitored is to match the speed of the label applicator to the product speed. An encoder uses “LINES or COUNTS” per revolution in order to track speed and distance. Note that lines per revolution are also referred to as counts per revolution. These counts are feed into the LabelMill control to be processed for the different features that require this feedback.
- **ENCODER OVERRIDE** – This feature is used in conjunction with ELECTRONIC GEARING. This feature is used to fine-tune the ratio of the applicator to the product conveyor.
- **TRIGGER DIST** – TRIGGER DISTANCE is used in conjunction with the encoder feature. Trigger distance is similar to product delay in that it is used to electronically move the placement of the label on the product. When the encoder feature is used, the product delay feature is rendered inactive. Trigger distance will move the label placement in inches (00.00).
- **PRODUCT DELAY** is NOT used in conjunction with the encoder feature. Product delay is similar to trigger distance in that it is used to electronically move the placement of the label on the product. Product delay will move the label placement in time (00.000) seconds. Because the product delay feature utilizes time, the speed of the product MUST remain constant. A product traveling at a higher velocity will travel further in a given time, thus effecting the placement of the label.

PROGRAMMABLE BLOCKS:

- **Conveyor Encoder** - Used to turn a connected external encoder option on or off.
- **Encoder Override** - Allows fine-tuning of the ratio of applicator speed to the moving conveyor speed.
- **Trigger Mode** - Used to select a timed product delay or measurable distance before sending a trigger signal.
- **Enc Trig Dist** - Used to apply the label a certain distance away from the trigger point.
- **Max Conv Speed** - Used to adjust what the max speed of the conveyor is.
- **Encoder LPI** - Programs how many pulses the encoder will count with 1"of travel.

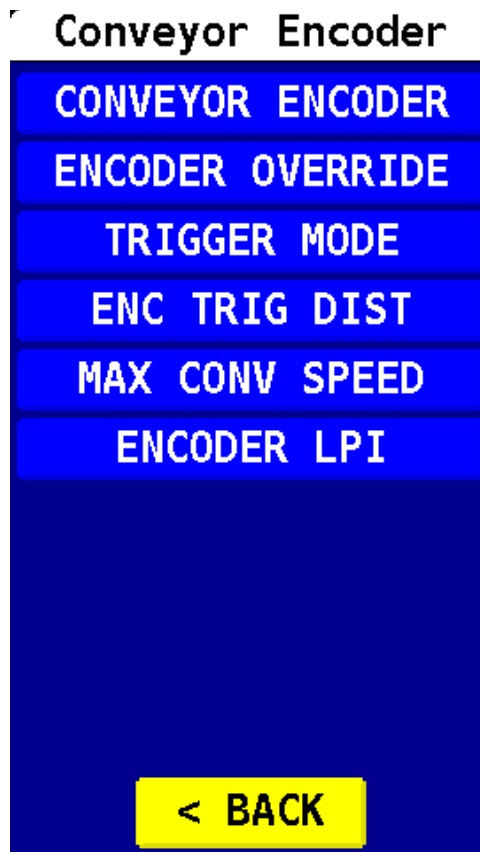

BACK

Use the "BACK" key to return to the main menu options.

CONVEYOR ENCODER

The Conveyor Encoder menu is used to turn the external encoder option on or off. Encoder signals will be ignored unless this is set to "On". Additional setup in the following menus is required for the system to operate properly. This option must be set to "Off" if an external encoder is not used.

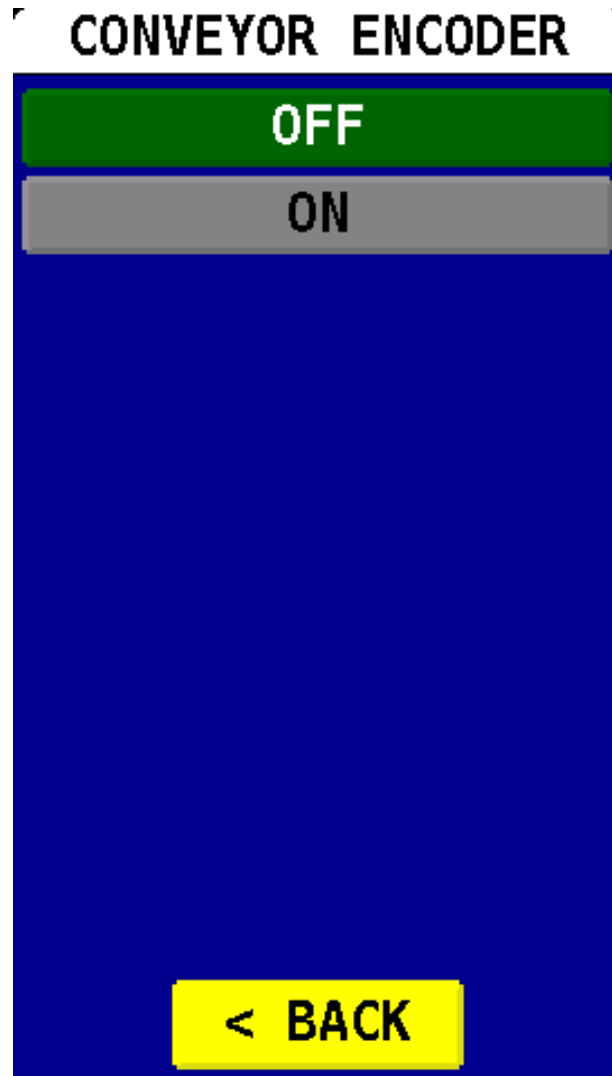

BACK

Use the "BACK" key to return to the main menu options.

ENCODER OVERRIDE

Allows fine-tuning of the ratio of applicator speed to conveyor speed.

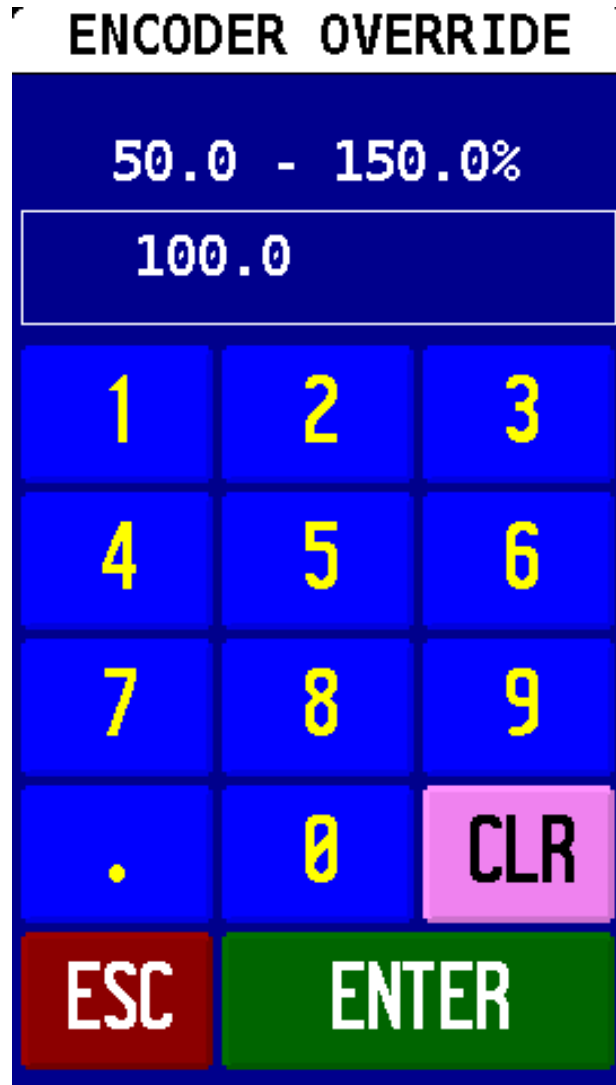

TRIGGER MODE

The Trigger Mode is used to select either Product Delay or Distance before a trigger signal is sent. If Product Delay is selected, the trigger signal will be sent once the programmed Product Delay timer expires. If Distance is selected, the trigger signal will be sent once the programmed travel distance has been met by monitoring the travel length by the external encoder.

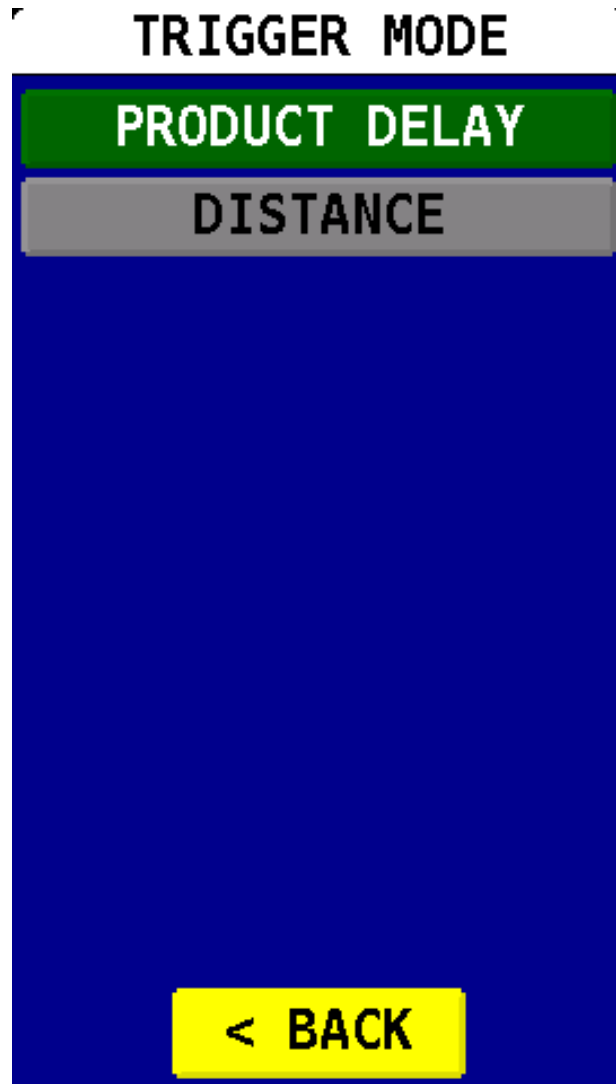

BACK

Use the "BACK" key to return to the main menu options.

ENC TRIG DISTANCE

The Encoder Trigger Distance option is used to apply the label a certain distance away from the trigger point. Once a trigger input is received, an external encoder will begin count the programmed lines per inch and send a signal to apply the label once the programmed value has been met.

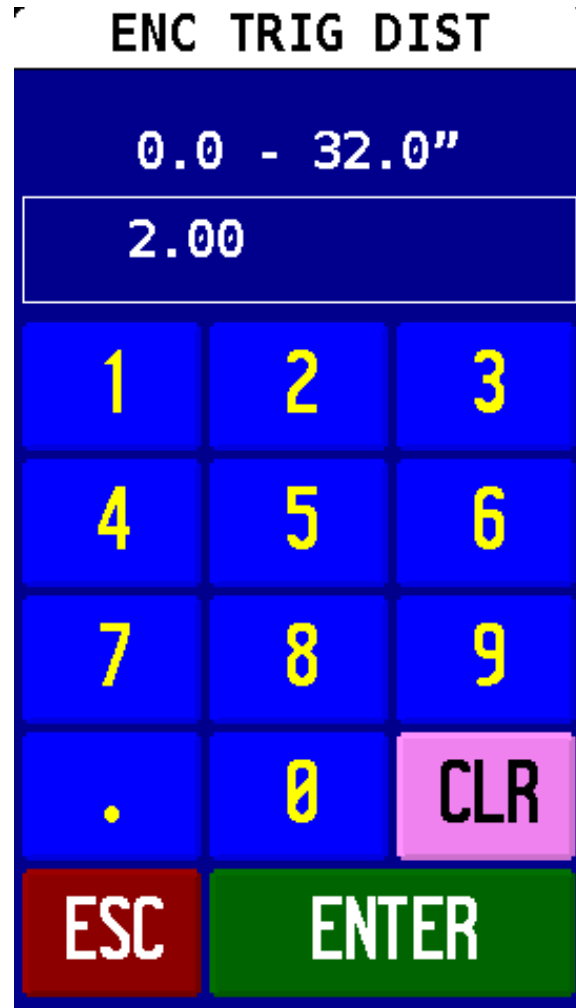

MAX CONVEYOR SPEED

The Max Conveyor Speed menu is used to adjust the maximum allowed speed of the conveyor. If the conveyor is operating outside of the maximum value, erratic label application may occur.

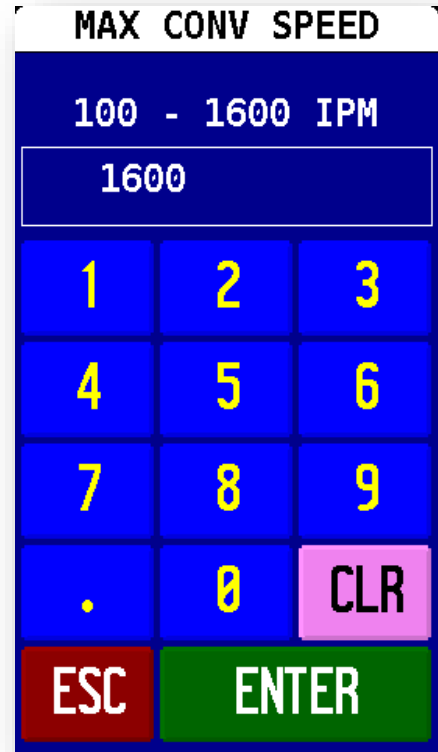

ENCODER LPI

Programs how many pulses the encoder will count with 1" of travel. This setting is dependent upon the external encoder hardware as well as the wheel size being used.

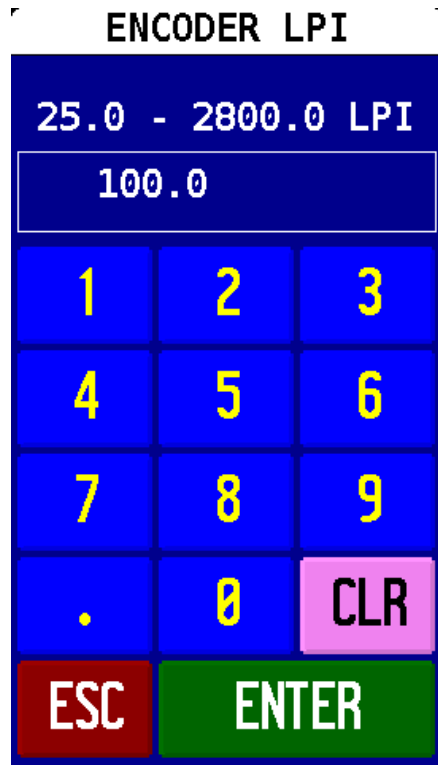

ALARMS

A “Label Feed Error” may be required in some custom applications, and this output can be enabled or disabled in the Alarms menu. For example, a tamp pad may be outfitted with a fiber-optic assembly to sense when a label is present on the pad. If the system is triggered and fiber-optic assembly does not sense the label, a “Label Feed Error” will occur. The use of this option may require custom software and/or hardware.

PROGRAMMABLE BLOCKS:

- **Label Feed Error** – Used to toggle the Label Feed Error option on or off.

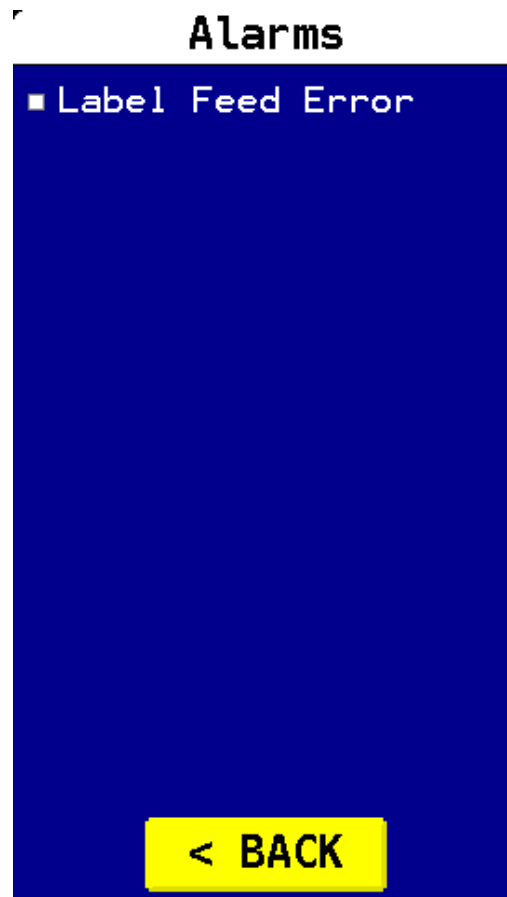

BACK

Use the "BACK" key to return to the main menu options.

ENABLE PASSWORD

The Enable Password is used to lock the menus of the control. This option is used to prevent unauthorized access to variable data. When shipped from the factory, the password is to 7074 and NO MENUS are locked. The password cannot be changed.

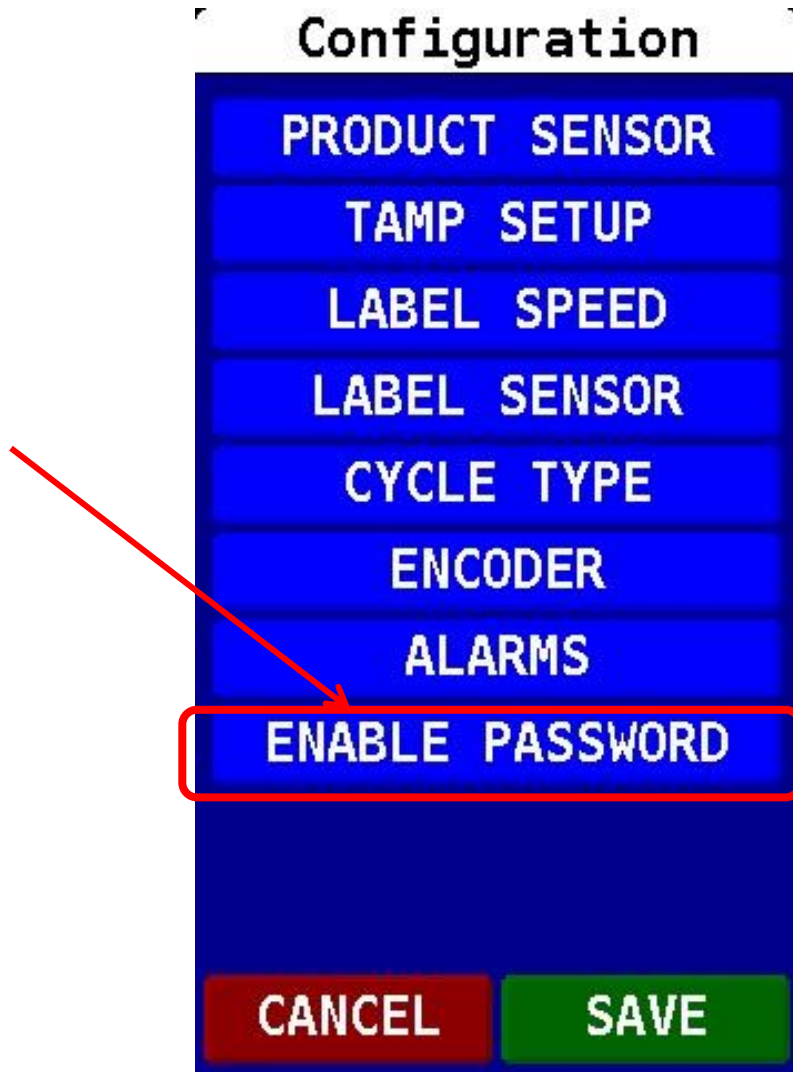

DESCRIPTION OF I/O

All user inputs and outputs are “SINKING” type.

I/O PANEL

Displays the status of the inputs and outputs.

X = On 0 = Off

A “green” character represents a signal that is currently in an “On” state, while a “grey” character represents a signal that is currently in an “Off” state.



BACK

Use the "BACK" key to return to the main menu options.

Logic Board Connections Shown Below

REMOTE TRIGGER CONNECTOR (PRODUCT SWITCH)	P7 PIN #	I/O	I/O Monitor Address
+24vdc	1		
+24vdc	2		
Trigger Input #1	3	Input	X0.0
Two Hand Start AUX1	4	Input	X0.1
24v Common	5		
24v Common	6		
Shield			

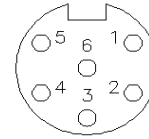

HEAD-UP / AUX IN	P8 PIN #	I/O	I/O Monitor Address
+24vdc	1		
+24vdc	2		
Head – Up/ Index Dwell	3	Input	X0.2
RM Part Present / Smart Tamp	4	Input	X0.3
24v Common	5		
24v Common	6		
Shield			

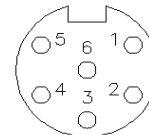

SMART TAMP	P2 PIN #	I/O	I/O Monitor Address
+24vdc	1		
+24vdc	2		
2 nd Trigger / Pre-Print AUX1	3		X0.1
Smart Tamp	4		X0.3
24v Common	5		
24v Common	6		
SHIELD			

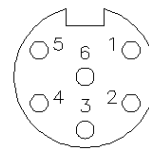

TAMP SOLENOIDS	P6 PIN #	I/O	I/O Monitor Address
Aux Output #2 / Tamp Slide / Powered Label Platen	1	Output	Y1.7
+24 Volt	2		
No connection	3		
Air Assist Sol 24vdc	4	Output	Y0.0
Vacuum Sol 24vdc	5	Output	Y0.2
Tamp Sol 24vdc	6	Output	Y0.3
Flag Sol 24vdc	7	Output	Y0.1
Shield			

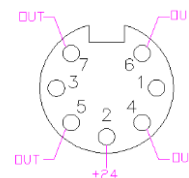

WEB SENSOR (LABEL)	P4 PIN #	I/O	I/O Monitor Address
Clear Label Detector	1	Input	X0.4
24v Common (+5dvc) LED	2		
Take-up output	4	Output	Y1.3
Logic Gnd	5		
Sensor Emitter (+)	6		
Sensor Collector (-)	7		
+24vdc	8		
Shield			

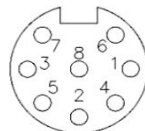

HMI RJ Conn	P3 PIN #	Jumpers
422RX+ (TXB)	1	
422RX- (RXB)	2	
	3	
	4	
24V Common	5	
+24vdc	6	
422TX+	7	
422TX-	8	

Light Bar/Auxiliary Connector 1 & 2 DB-15 Female	P10 Pin #	I/O	I/O Monitor Address	
+24vdc	1			
+24vdc	2			
24 Com	3			
24 Com	4			
Low Label In	5	I	X0.5	
ERROR LITE (Red Light)	6	O	Y0.6	On=GREEN Off=RED
LOW LABEL (Yellow Light)	7	O	Y0.7	
Run Status Ok (Green Light)	8	O		Green = /Red
Tamp Sync Out	9	O	Y1.1	
Inhibit In	10	I	X0.6	
Reprint / Aux Input #2	11	I	X0.7	
Aux Input #3 / Slide Home Input	12	I	X1.1	
Aux Input #4 / Feed Error Input	13	I	X1.2	
Applicator In Cycle Output (Applicator Busy)	14	O	Y1.2	
Batch Done Aux Output #1	15	O	Y1.6	

Serial Plus Port / RM Stepper Motor DB9 Female (Optional)	P11 PIN #	I/O	I/O Monitor Address
SHIELD	1		
+485 RS232 XMIT (port D) to motor	2		
-485 RS232 RECV (port D) to motor	3		
24C	4		
24C	5		
Tamp Slide / Aux Output #2 High current	6	O	Y1.7
REPRINT / Aux Input #2	7	I	X0.7
+24	8		
+24	9		

USERS MANUAL

Conveyor Encoder Interface DB9 Female Male <i>(Optional)</i>	P14 PIN #	I/O Monitor Address
A+	1	I
A-	2	I
B+	3	I
B-	4	I
+5V	5	
GND	6	
Shield	7	
No Connection	8	
No Connection	9	

Printer Interface 14 pin Centronix <i>(Optional)</i>	P9 PIN #	I/O	I/O Monitor Address
Paper End	1	Input	X1.3
Printer Ground	2		
Ribbon End	3	Input	X1.4
Printer Error	4	Input	X1.5
Print Start	5	Output	Y0.4
Print End	6	Input	X1.6
Reprint	7	Output	Y0.5
	8		
ONLINE (Sato Only) (Zebra Data Ready)	9	Input	X1.7
Ribbon Near End	10	Input	X1.0
	11		
	12		
+5vdc From Printer	13		
	14		
Shield			

AUX 2 Auxiliary Connector 3rd DB-15 Male <i>(Optional)</i>	P13 PIN #	I/O	I/O Monitor Address	
AUX 232 TXC Port C	1	O		RS232 Output
GND	2			
GND	3			
Batch Done Aux Output #1	4	O	Y1.6	
REPRINT / Aux Input #2	5	I	X0.7	
Aux Input #4 / Feed Error Input	6	I	X1.2	
+24V	7			
+24V	8			
AUX 232 RXC Port C	9	I		RS232 Input
24MCR	10			24 Volts when not in E-Stop
24MCR	11			24 Volts when not in E-Stop
Estop relay	12	relay		Used to seal E-Stop
Aux Input #3	13	I	X1.1	
Tamp / Aux Output #2 / Powered Label Platen	14	O	Y1.7	High current
+24V	15			

Optional connections; consult factory for custom programming and connection.

SECTION 5

CLEANING & MAINTENANCE

Description	Page
General Cleaning	80
Troubleshooting	81
Fault Codes	82
Replacing Main Power Fuse	83

GENERAL CLEANING & MAINTENANCE

The system should be inspected and cared for properly before operation begins. Typical inspection includes confirming correct supply spool loading, web path, checking air pressure, ensuring rollers are clean and free of adhesives, checking pinch assembly operation, and label feed position. Do not attempt to operate system if not in good working order.

Preventative maintenance procedures should be performed at least once per week. This includes removing adhesive and residual build-up from system components, cleaning the label sensor, cleaning the tamp pad, and cleaning the pinch rollers.

To clean adhesive or residual build-up off of guide rollers, brake arms, or the pinch roller assemblies, use only isopropyl alcohol. Other chemicals or abrasive products can cause damage to the system, resulting in poor operation. **Do not use sharp objects or aggressive solvents on the pinch roller assemblies to remove labels or adhesive!**

Use clean, dry, compressed air to remove dust, dirt, or label debris from the label sensor, if applicable. **Do not use any abrasive objects to clean the sensor slot, as it will cause un-repairable damage to the sensor.**

The tamp pad should be cleaned with isopropyl alcohol to remove adhesive or debris build-up. The pad must be clean and smooth for the labels to feed properly. If adhesive is blocking any vacuum holes, use isopropyl alcohol to break down the adhesives and clean the holes. **Do not use sharp objects or aggressive solvents on the tamp pad assembly to remove labels or adhesive!**

TROUBLESHOOTING GUIDE

If the system malfunctions, it is necessary to determine where the problem exists in a normal sequence of operation. Possible error conditions are listed in the left-hand column to provide a systematic approach to troubleshooting.

Error Condition	Possible Cause	Corrective Action
Unit will not turn on	Blown main fuse	Check main power fuse and replace if necessary
Air system will not operate	No air pressure Plugged hose Faulty valve	Check air supply and filter Fix or replace hose Consult factory
Take-up unit does not turn	Cable Disconnected Friction plate failure in clutch Mechanical failure in clutch	Check Motor Connection Consult Factory
Waste web tension too loose	Clutch tension too low	Adjust clutch
Waste web breaks	Clutch adjusted too tight Machine webbed wrong Low quality webbing Friction plate failure in clutch Mechanical failure in clutch	Adjust clutch Re-web system correctly Consult label manufacturer Consult factory. Consult factory.
Label double feeds	Web sensor out of adjustment	Adjust setting / recalibrate
Tamp cylinder not up	A. No air B. Hoses not connected correctly C.	Connect air and/or adjust regulator
Applicator module does not function	Incorrect Cycle Type D. No air Hoses not connected correctly	Set correct Cycle Type in control Connect air and/or adjust regulator
Tamp/flag system unit will not cycle	Cylinder not up Reed Switch out of adjustment Incorrect Cycle Type	Connect compressed air connection Adjust Switch up or down Set correct Cycle Type in control

FAULT CODES

DISPLAYED FAULT	DESCRIPTION	CORRECTIVE ACTION
Memory Checksum	Data lost in serial EEPROM	Consult factory or service provider
Gap Not Detected (10 second time out)	Too many labels missing on web Labeler not webbed properly Web sensor not adjusted properly	Check label stock Check for proper webbing Adjust setting / calibrate sensor
Label Not Found	Label not sensed in auto set up	Check label stock Check label sensor position Adjust setting / calibrate sensor
Head Up Fault	Head up limit switch on tamp did not trigger	Check for proper adjustment of head up limit switch Check air to system Check programming of Tamp switch
Head Down Fault	Head up limit switch failed to switch during the tamp cycle	Tamp duration too small Faulty limit switch Check air to system Check programming of Tamp switch
Print Timeout Fault	End of Print Signal was not received with "Printer" setting enabled	Turn off Printer setting (if external printer is not being used). Check Printer Settings. Inspect / Replace Interface Cable.

REPLACING THE MAIN POWER FUSE

The circuitry is protected from a current overload by GMA a slow blow fuse. Should the applicator fail to operate, the condition of this fuse should be checked. If the fuse is open, the cause of the overload condition must be determined and corrected prior to replacing the fuse. NEVER replace the fuse with one of a greater amp rating shown on the label. The specified rating has been selected to prevent damage and/or injury.

ACTIONS TO REPLACE THE MAIN FUSE

1. Set the main power switch to the OFF position.
2. Disconnect the AC power cable from the rear of the console.
3. Locate the fuse holder/power cord assembly.
4. Gently press down the fuse holder cover while pulling away from the console.
5. Replace with the spare fuse provided in the holder.

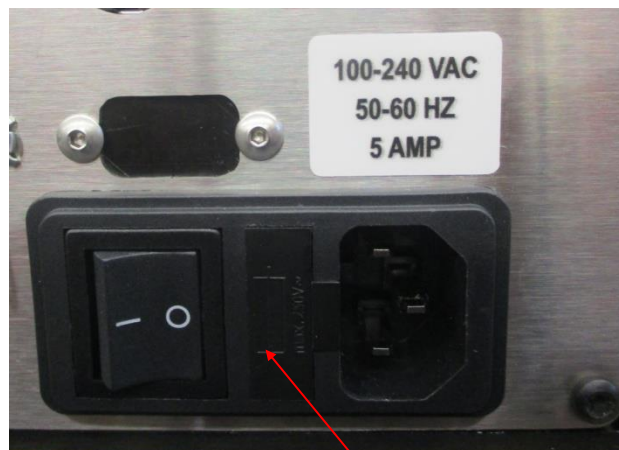

Fuse / Spare Fuse Drawer

LM4012

AUTOMATIC LABEL APPLICATOR

OPERATIONS MANUAL



Copyright and Trademarks

Copyright ©2023 LabelMill
All rights reserved. All trademarks and brand names
are the property of their respective owners.

LabelMill
2416 Jackson St.
Savanna, IL 61074

Phone: (800) 273-4707; Fax (815) 273-7074
www.labelmill.com
info@labelmill.com