



LM4012

AUTOMATIC LABEL APPLICATOR OPERATIONS MANUAL



Manufactured in USA by:

LabelMill, Inc.

2416 Jackson St.

Savanna, IL 61074

(800) 273-4707

info@labelmill.com

www.labelmill.com

TABLE OF CONTENTS

SECTION	PAGE
1. APPLICATOR OVERVIEW	
Introduction	4
General Applicator Specifications	4
Inventory List	5
User Responsibility/Safety	6
2. WEBBING, SETUP AND GENERAL OPERATION	
LM4012 Component Description	8
Web Routing (Synchronous Feed Module)	9
Web Routing (Tamp Module)	10
Label Sensor Position Adjustment	11
Label Sensor Calibration	12
Optional Mechanical Label Sensor	13
Optional Electronic Clear Label Sensor	14
Drive Motor Pack Assembly	15
Adjusting Web Tension (Clutch Adjustment)	16
T-150 Mounting Stand (Optional)	17
T-Stand Adjustment	18
3. SETUP & ADJUSTMENT	
Valve Pack	20
Tamp Assembly & Setup	21
Flag Assembly & Setup	22
Synchronous Feed (Wipe-On) Setup	23
4. PROGRAMMING AND CONTROL OPERATION	
Hand Held Labeler Interface HLI-112	25
Control Accessory Connections	26
T-52 Photo Eye	27
System Setup - Programming	28
Programming Flow Chart	31
Key Definitions	41
Set Up of Key Features	42
Quick Start & Manual Setup (Asynchronous Configuration)	43
Input & Output Description	45
5. TROUBLE SHOOTING & MAINTENANCE	
Troubleshooting	50
Fault Codes	51
Replacing the Main Power Fuse	52

SECTION 1

APPLICATOR OVERVIEW

Introduction	4
General Applicator Specifications	4
Inventory List	5
User Responsibility & Safety	6

LabelMill LM4012

DYNAMIC LABEL APPLICATOR

The **LabelMill LM4012** is a state of the art, medium speed, heavy-duty industrial Label Applicator. Label applications up to 1600 linear inches of label web per minute are combined with an exceptional placement accuracy of up to +/- 1/32", with multiple methods of application. Products may be labeled in any attitude (top, side or bottom) when used in conjunction with available product handling systems. Outboard-supported drive roller to minimize vibration induced label misplacement. Hybrid servo motor drive. Hardened steel peeler plate for reduced wear with high-speed continuous label application. Adjustable label sensor for expediting changeover without sacrificing accuracy. The **Model LM4012** is transferable from one production line to another when mounted on the **LabelMill Model T-150 Stand**. The **Model LM4012** applicator is of modular design and features rapid changeover from a wipe-on system to a tamp system using the same applicator platform and controller. The microprocessor controls the hybrid servo motor for accurate and consistent label placement. The **Model LM4012** has a HLI-112 (Hand Held Labeler Interface) with digital LCD display and key pad for ease of set-up to include IPM, product delay, batch count, total count, tamp duration and more.

SPECIFICATIONS

Size:	26"H x 32"W x 23"D Weight – 50 lbs.
Electrical:	115V AC, 60 Cycle, 2 amps
Product Sensing:	Photoelectric or Mechanical Limit Switch
Label Roll Size:	12" Max Outside Diameter, Wound on 3" I.D. core
Labeling Speed:	1600 Linear Inches of Web per Minute, Standard
Label Style Requirements:	Die-Cut, Waste Removed, with Minimum of 1/8" Separation Between Labels in Running Direction
Label Placement Accuracy:	Up to +/- 1/32" When Labels are Produced to Specifications and Product Handling is Controlled
Options:	Right or Left Handed Wipe-On, Tamp Unit or Corner Wrap*
Standard Label Sizes:*	4 1/2" Wide, 12" Long or optional 6 1/2" Wide, 12" Long*

*Optional lengths and sizes available

*Customs Available

INVENTORY LIST

QTY.	Description
1	Applicator Assembly
2	12-1/2" dia. Blue Plastic Spools w/ Quick Release Collar
1	7-3/4" dia. Take-Up Spool w/ Bolts
2	1/2" – 13 bolts w/ Washers
1	10' Power Cord
1	Product Switch (Manual Limit Switch/Photo Switch as Specified)
1	Take-up Spool Clip
1	Electronic Web Sensor
1	Model LM4012 Operators Manual

USER RESPONSIBILITY

This equipment will perform in conformity with the description thereof contained in this manual and accompanying labels and/or inserts when installed, operated, maintained, and repaired in accordance with the instructions provided. This equipment must be checked periodically. Defective equipment should not be used. Parts that are broken, missing, plainly worn, distorted, or contaminated should be replaced immediately. Should such repair or replacement become necessary, we recommend that a request for service advice be made.

This equipment or any of its parts should not be altered without the prior written approval of MM2, Inc. The user of this equipment shall have the sole responsibility for any malfunctions which results from improper use, faulty maintenance, damage, improper repair or alteration by anyone other than MM2, Inc., or a service facility designated by MM2, Inc.

SAFETY

- Only qualified personnel should use this equipment.
- Before installing, inspecting or servicing equipment, turn OFF all power and air controls at the source and lock out in accordance with OSHA Standards.
- Be sure all external electrically conductive parts are connected to a good electrical ground.
- Never handle live electrical equipment with bare hands while standing in water, or while hands and feet are wet. Dangerous electrical shock can result.
- Whenever the equipment is unattended, turn off all control and power supply switches.
- Keep equipment clean and in good operating condition. Promptly repair or replace all worn or damaged hoses, cables or parts.
- Do not make any repairs to equipment unless you are fully qualified.
- This equipment contains fast moving parts, which may move without warning. Keep hands, loose hair and clothes clear of machines at all times.
- Never place hands or any other body parts under the label platen at any time.
- This equipment uses compressed air. Proper care and maintenance must be taken when handling compressed air and its components.
- These precautions are further detailed and explained where specifically required in this manual.



WARNING

READ AND UNDERSTAND THESE INSTRUCTIONS

Protect yourself and others. Be sure this information is read and understood by all operators.

ELECTRICAL SHOCK CAN KILL!

Do not touch live electrical parts with bare skin or work with gloves or wet clothing.

NOISE CAN DAMAGE HEARING!

Wear proper ear protection.

SECTION 2

WEBBING, SETUP AND GENERAL OPERATION

LM4012 Component Description	8
Web Routing (Synchronous Feed Configuration)	9
Web Routing (Tamp Configuration)	10
Label Sensor Position Adjustment	11
Label Sensor Calibration	12
Optional Mechanical Label Sensor	13
Optional Electronic Clear Label Sensor	14
Drive Motor Pack Assembly	15
Adjusting Web Tension (Clutch Adjustment)	16
T-150 Mounting Stand (optional)	17
T-Stand Adjustment	18

COMPONENT DESCRIPTION

NOTE: LM4012 SYNCHRONOUS FEED CONFIGURATION (LEFT HAND) SHOWN FOR REFERENCE ONLY

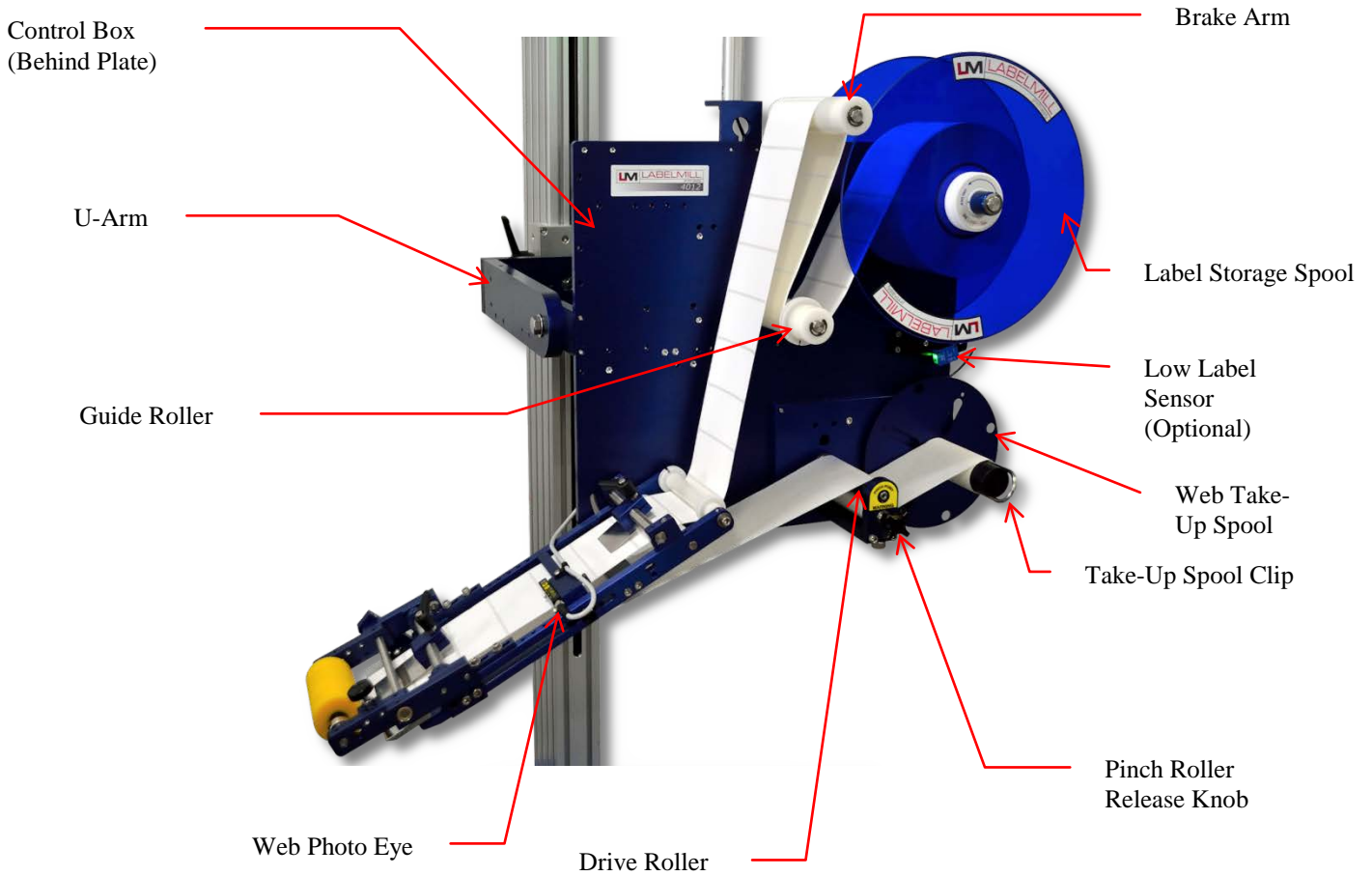

WEB ROUTING

(Right Hand - Synchronous Feed Configuration)

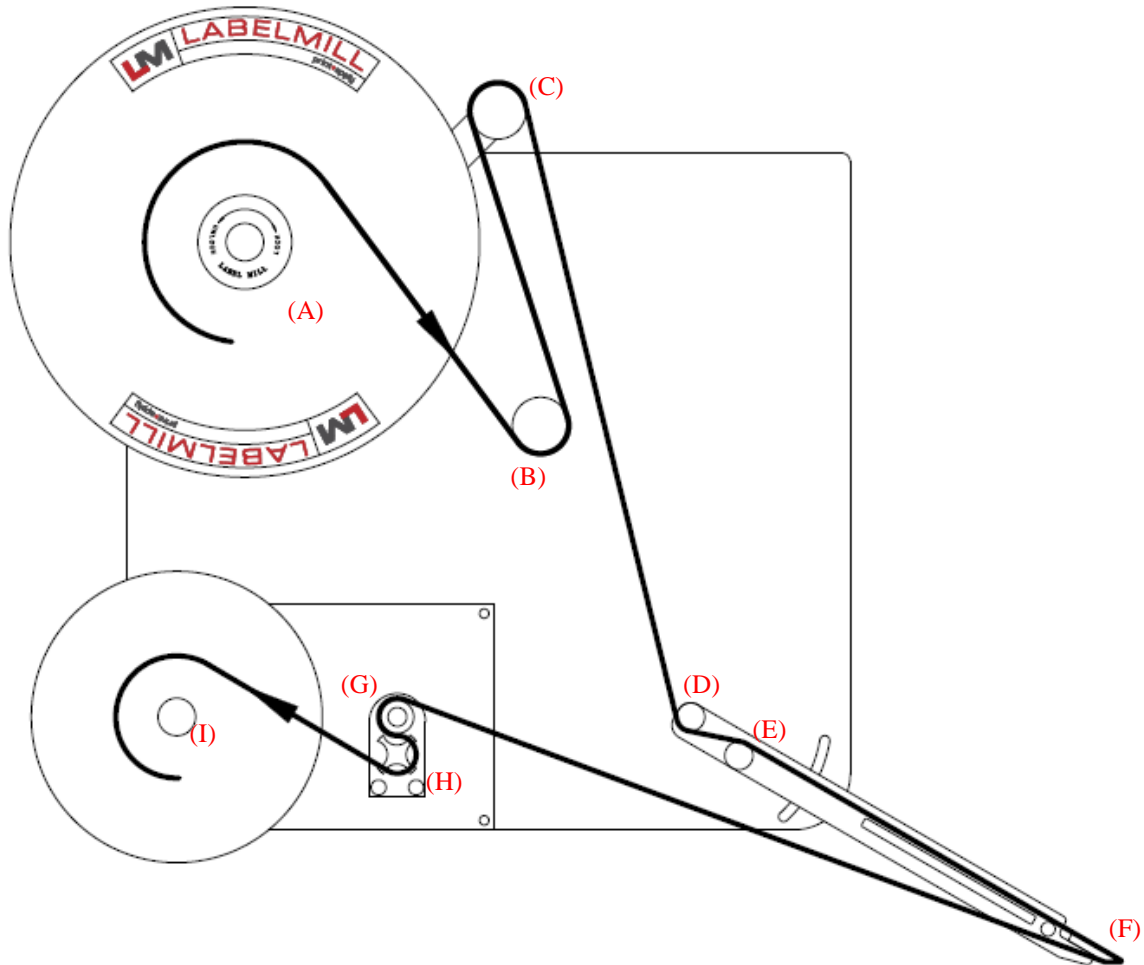

Step	Operation
1	Load web onto label storage spool (A) so it unloads in a clockwise direction.
2	Feed the web to the right and under the idle roller (B) .
3	Feed the web up and over brake arm roller (C) .
4	Feed the web under roller (D) , and over roller (E). Feed web through label sensor.
5	Wrap the web around peeler plate (F) and pull the web back towards pinch assembly slip the web between the drive roller and the pinch roller (F) . Continue on by wrapping the web under the pinch roller (F) .
6	Feed the web over drive roller (G) , between both rollers, and under pinch roller (H)
7	Finish the process by loading the waste backing paper onto the web take-up shaft (I) . Install the take-up spool clip over the end of the waste backing paper. The take-up spool rotates in a counter-clockwise direction.
8	Adjust the plastic web guide clips so the web is guided straight and even. Make sure the clips do not bind the web.
9	Lock the wiper assemblies with light tension, and close the pinch roller assembly.

** To remove the label storage spool (A), turn the spool lock counterclockwise until you reach a stop. The spool will now slide off. To secure the spool, simply turn the spool lock clockwise until snug. DO NOT over tighten!

WEB ROUTING (Right Hand - Tamp Configuration)

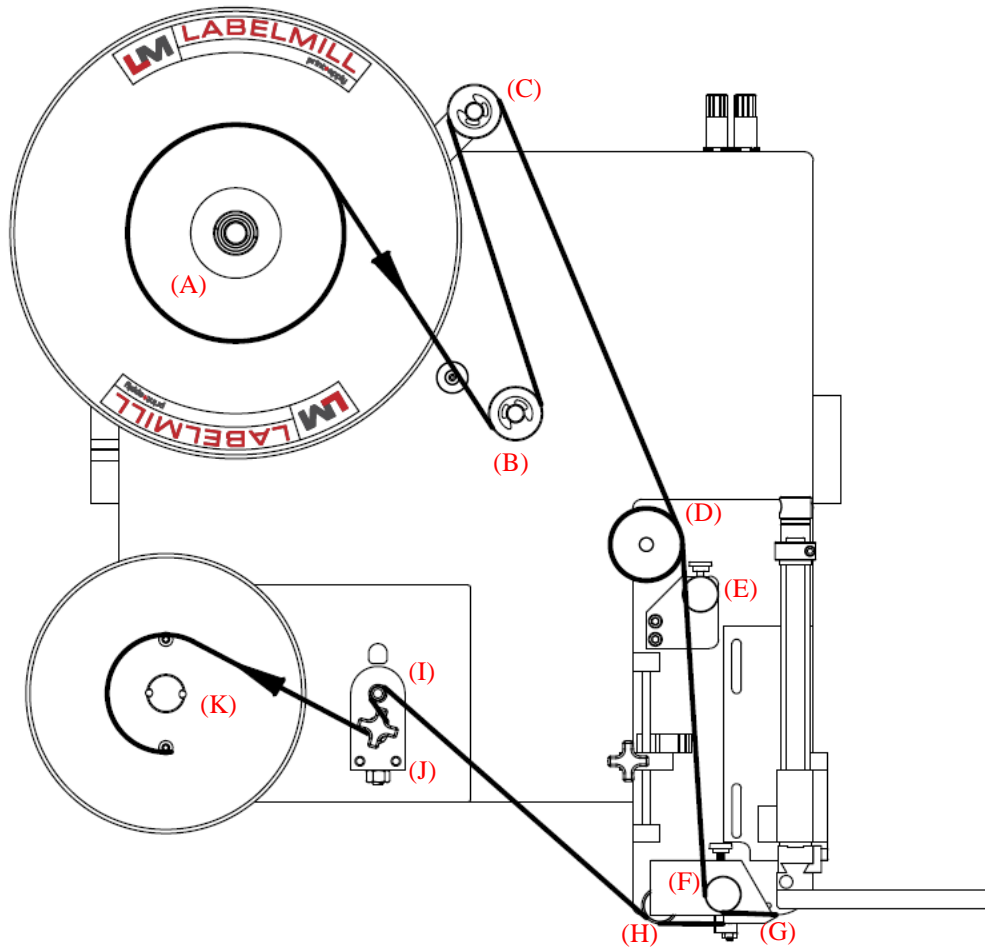

Step	Operation
1	Load web onto label storage spool (A) so it unloads in a clockwise direction.
2	Feed the web to the right and under idle roller (B).
3	Feed the web up and over brake arm roller (C).
3	Feed the web down and over guide roller (D) and through wiper assembly (E).
4	Feed the web under idle roller (F), continuing around peeler plate (G) .
5	Ensure web is fed between the peeler plate and air assist tube. Feed the web under idle roller (H), and continue up to the pinch assembly.
6	Feed the web over drive roller (I), between both rollers, and under pinch roller (J)
7	Finish the process by loading the waste backing paper onto the web take-up spool (J). Install the take-up spool clip over the end of the waste backing paper. The take-up spool rotates in a counter-clockwise direction.
8	Adjust the plastic web guide clips so the web is guided straight and even. Make sure the clips do not bind the web.
9	Lock the wiper assemblies with light tension, and close the pinch roller assembly.

** To remove the label storage spool (A), turn the spool lock counter-clockwise until you reach a stop. The spool will now slide off. To secure the spool, simply turn the spool lock clockwise until snug. DO NOT over tighten!

LABEL SENSOR POSITION ADJUSTMENT (Synchronous Feed Configuration Shown)

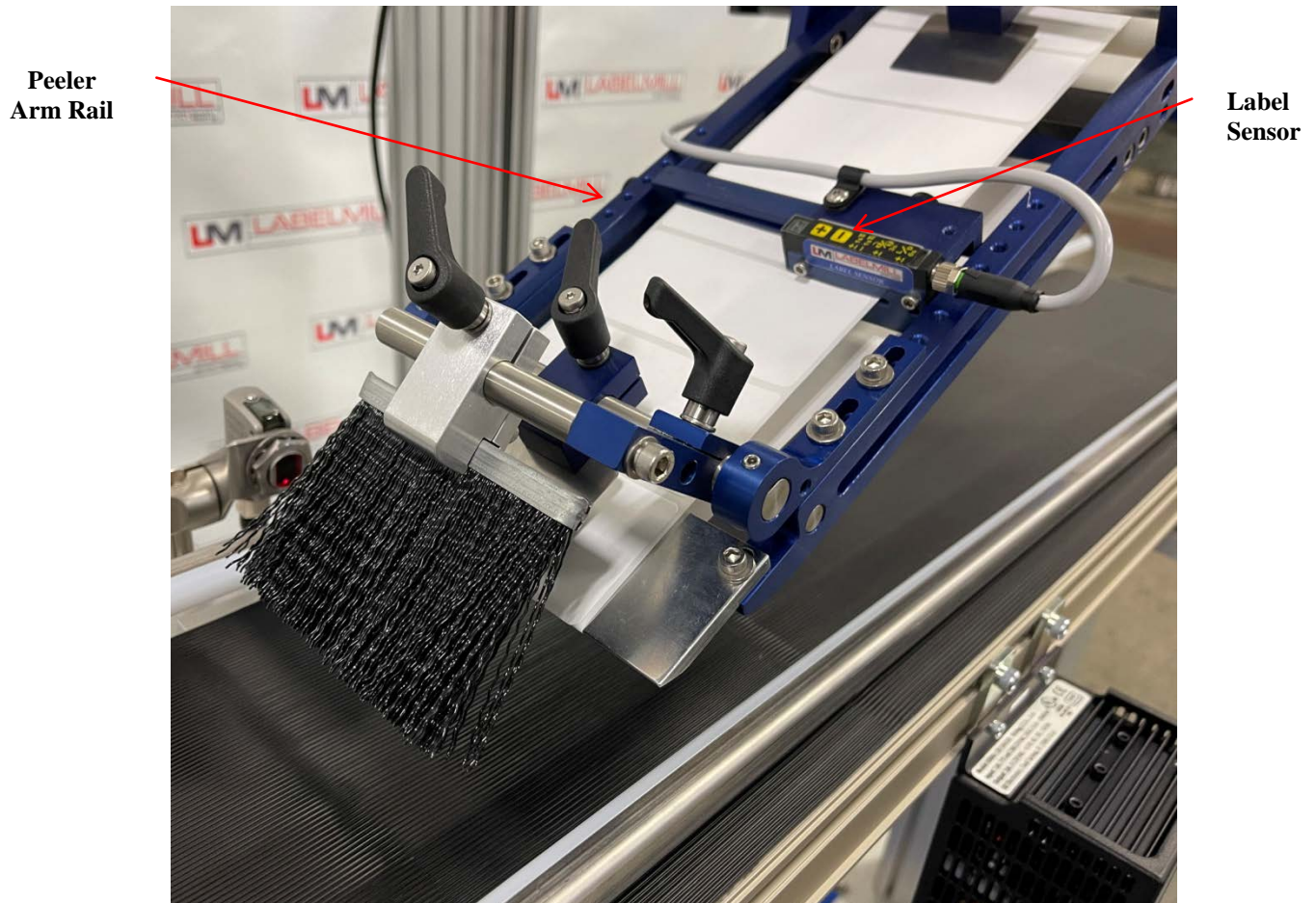

The label web must be fed through the label sensor slot to detect the label. Once the system is webbed with labels, loosen the thumbscrew that mounts the label sensor, and slide it into the web.

Manual adjustment of the label in relation to the peeler plate is achieved by loosening the thumbscrew on the label sensor bracket and sliding the assembly up or down on the peeler arm rail.

Once the label sensor is manually adjusted, calibrated correctly, and properly configured in the control, trigger the applicator to test the position of the label in relation to the peeler plate.

The label position should be adjusted so that the label stops at the edge of the peeler plate. If the label is not fully removed from the liner, or if the label has fed out too far past the edge of the peeler plate, additional adjustment is required.

NOTE: The label sensor setting must be set to "CLEAR" in the Label Sensor program menu for the standard label sensor to function properly.

Z-Z-ELS100 LABEL SENSOR CALIBRATION INSTRUCTIONS

Teach Mode Setup Procedure:

1. Place the web liner in the sensor (remove a label or use the label gap).
Press the [+] and [-] buttons at the same time for less than one second.
The red LED will begin to flash.
2. Place the web liner, **with a label**, in the sensor.
Press the [-] button for less than one second.
The red LED will stop flashing.
3. The automatic setup is complete. (Steps 1 and 2 can be reversed)



Manual Sensitivity Adjustments:

The "Teach Mode Setup" should always be successful. However, the sensitivity can be adjusted manually by pressing the [+] or [-] buttons. The red LED will flash with each button press.

Locking/Unlocking the Setup:

Press and hold the [+] and [-] buttons for three seconds (but less than six seconds). The red LED will change state. When the buttons are released, the red LED will then indicate locked (red LED on) or unlocked (red LED off).

Light/Dark Switching:

Press and hold the [+] and [-] buttons for six seconds. When the mode is changed, the red LED will begin to flash slowly until the buttons are released.

OPTIONAL MECHANICAL CLEAR LABEL DETECTOR

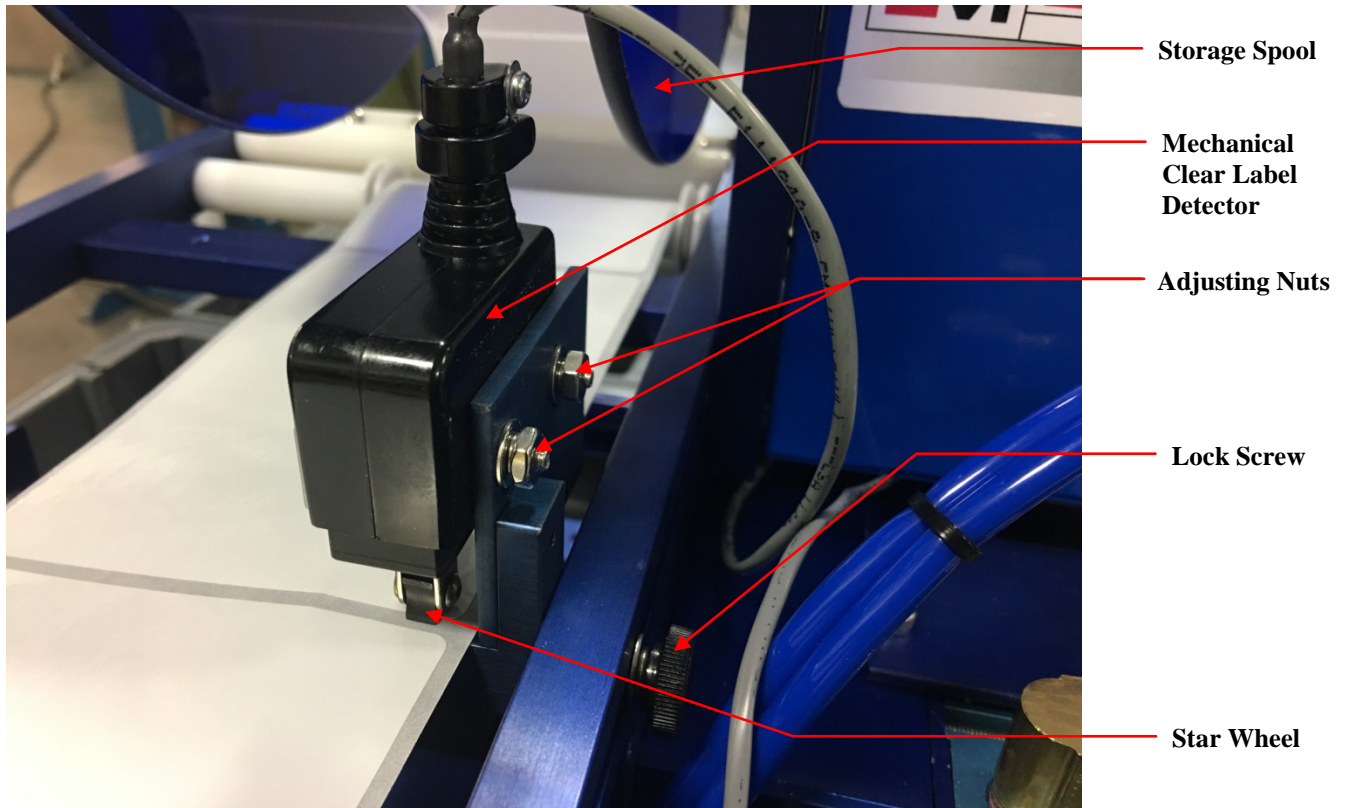

The Mechanical Clear Label Detector comes preset from the factory and should require no adjustment. If there is a need to readjust the sensor, the following is a guide: Move the label stock until the gap between the labels are centered under the Star Wheel and the star wheel is laying flat on the label stock as shown above. This can be accomplished by unwinding the label storage spool enough to make the web "loose". To test adjustment, move the label stock gap back and forth under the photo eye slowly. The STAR WHEEL catches the edge of the label stock and flips from one flat to the next. The STAR WHEEL detects the gap between the labels by catching the edge of the label as it is fed. When the star wheel catches the edge of the label, the wheel will stop sliding and rotate. The diameter across the flats of the star wheel is smaller than the diameter across the points. When the star wheel rotates, the micro switch is activated indicating the gap in the label stock.

If double or multiple label feeding occurs, and the micro switch is always activated, loosen the adjustment nuts and slide the micro switch up away from the label.

If double or multiple label feeding occurs, and the micro switch never activates, loosen the adjustment nuts and slide the micro switch down towards the label.

LABEL PLACEMENT IN RELATION TO THE PEELER PLATE:

- Loosen the lock screw on the **Mechanical Label Sensor Assembly** and slide it forward or backward on the adjustment rails to achieve placement of the label with the peeler plate nose (+/- 1/32). After adjustment, cycle the labeler to verify new label placement.

OPTIONAL ELECTRONIC CLEAR LABEL DETECTOR (ECLD)

Description

The Z-Z-ELC300 Label Sensor uses capacitive technology to sense label edges for registration, counting, splice detection or other applications. Capacitive technology provides the fastest and most accurate edge detection method available. The Z-Z-ELC300 has an integral cable, and uses an M12 connector.

Setup

1. Web must remain in contact with the base/mounting plate during operation.
2. Label must pass under the [-SENSOR-] indicator.
3. Small labels should be centered under the [-SENSOR-] indicator.
4. When properly setup, the lights in the gray LABEL area will be on when a label is present, and lights in the gray GAP area will be on when a gap is present.
5. All lights flashing rapidly indicates over-current condition, likely caused by wiring error.

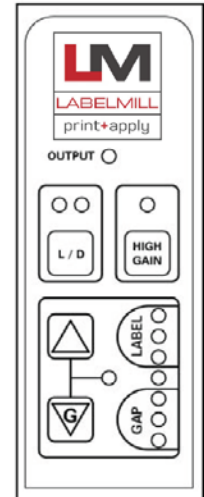

AutoGap Setup

1. Start with High Gain off.
2. Remove a label from the web.
3. Place the area of the missing label in the sensor (liner only).
4. Press for at least 1 second (lights begin to move back and forth).
5. Release the button.
6. Setup complete.
7. Verify the light bar goes into the gray GAP area during gaps between labels and into the gray LABEL area during labels. If necessary, use arrow keys to adjust manually. If the light bar is not moving at least three or four lights, turn on High Gain.

Manual Adjustment

When running, the light bar should extend from the gray LABEL area to the gray GAP area. The up and down arrows can be used to fine tune the adjustment if necessary. If the adjustments reach the end of their range, the last light in the GAP or LABEL area will flash three times when the button is pressed. The light bar may move toward LABEL while the Up arrow is pressed. This is because the sensor body is deflecting and making the slot smaller. It will return when the button is released and will not affect setup.

Sensor Configuration

Light/Dark Switching: In “Light” switching mode, the sensor outputs are active/on during the gap. In “Dark” switching mode, the sensor outputs are active/on during the label. Switch modes by pressing the button. Do not change while running.

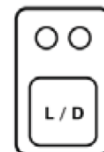

High Gain Mode

Only use High Gain mode when necessary. Very small or very thin labels may not consistently move the light bar between the LABEL and GAP areas. In this case, use the High Gain mode by pressing the button. Do not change while running. AutoGap must be performed after activating High Gain.

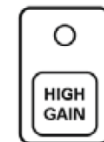

Metal/Foil Label Setup

AutoGap Setup on a missing label area may not work reliably for rectangular metallic labels (foil or metalized Mylar). In this case, place an actual gap in the sensor (use alignment groove on the sensor). Then hold the Gap button down for AutoGap as above. Move labels slowly through the sensor. Use manual adjustments if necessary to ensure the light bar is in the LABEL area during labels and GAP area during gaps.

LM4012 DRIVE MOTOR PACK ASSEMBLY

EXPLODED VIEW BELOW

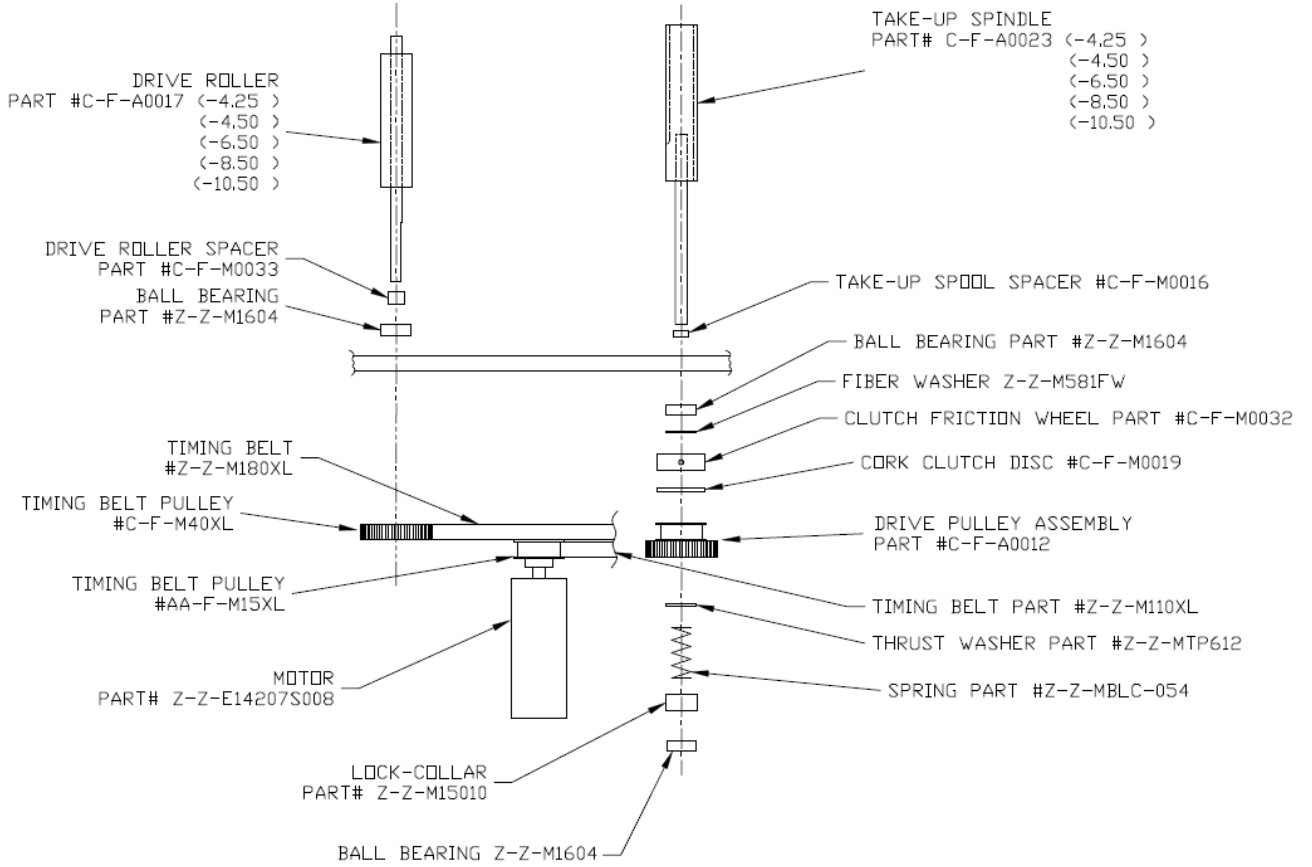

ADJUSTING THE WEB TENSION

If the web tension becomes too loose or too tight, adjustment of the clutch may be required. To adjust the clutch remove the motor pack cover plate by removing the (2) cap head bolts.

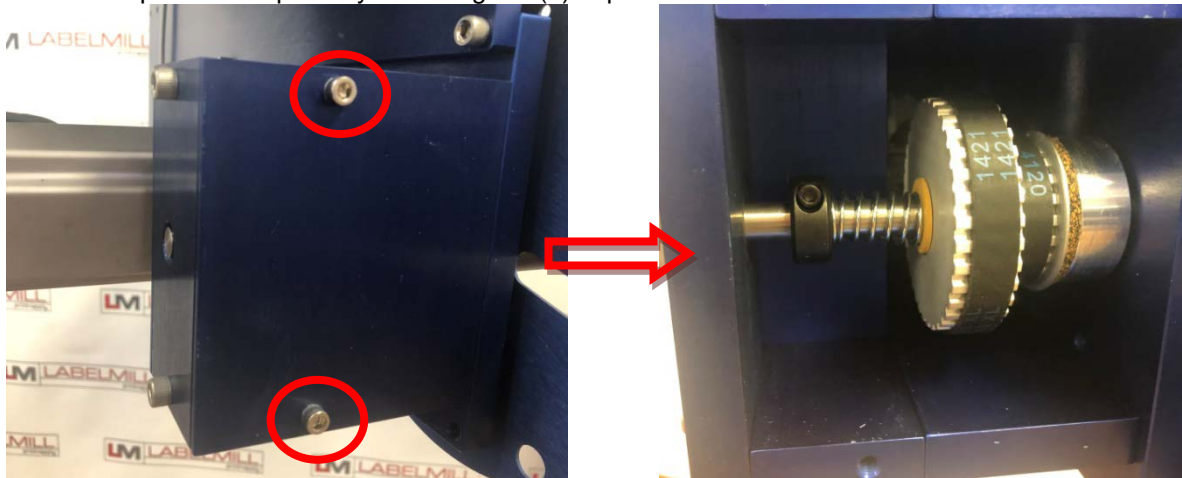

To reduce waste web tension, move the lock collar 1/32" away from the take-up spool. To increase waste web tension, move the lock collar 1/32" toward the take-up spool.

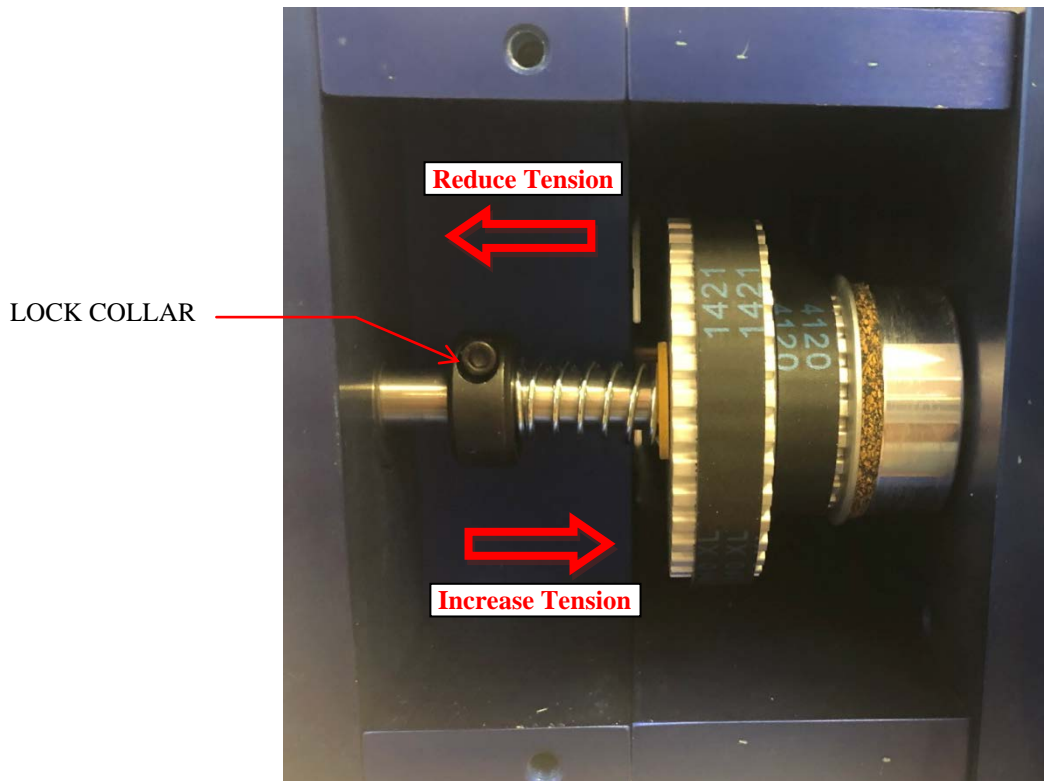

CAUTION! Too much web tension may cause web breakage, label drifting or premature failure of the take-up spool assembly.

T-150 MOUNTING STAND (OPTIONAL)



T-STAND ADJUSTMENT

Column Crank



Column Lock



To adjust the T-150 mounting stand, simply loosen the headlocks and adjust to the desired height by turning the column crank. Be sure to lock the headlocks when finished.

SECTION 3

SETUP & ADJUSTMENT

Valve Pack	20
Tamp Assembly & Setup	21
Flag Assembly & Setup	22
Synchronous Feed (Wipe-On Assembly)	23

VALVE PACK

(Not Included in Synchronous Feed Configuration)

There are solenoid valves associated with applicators using pneumatics. They are supplied with pre-wired cables that connect to the necessary components.

There is an adjustment for airflow for each valve. This will change the rate at which air will flow through each valve. It may be necessary to adjust each valve for optimum performance after installation. The adjustments are performed as shown below.

(Pictures may not show actual model)

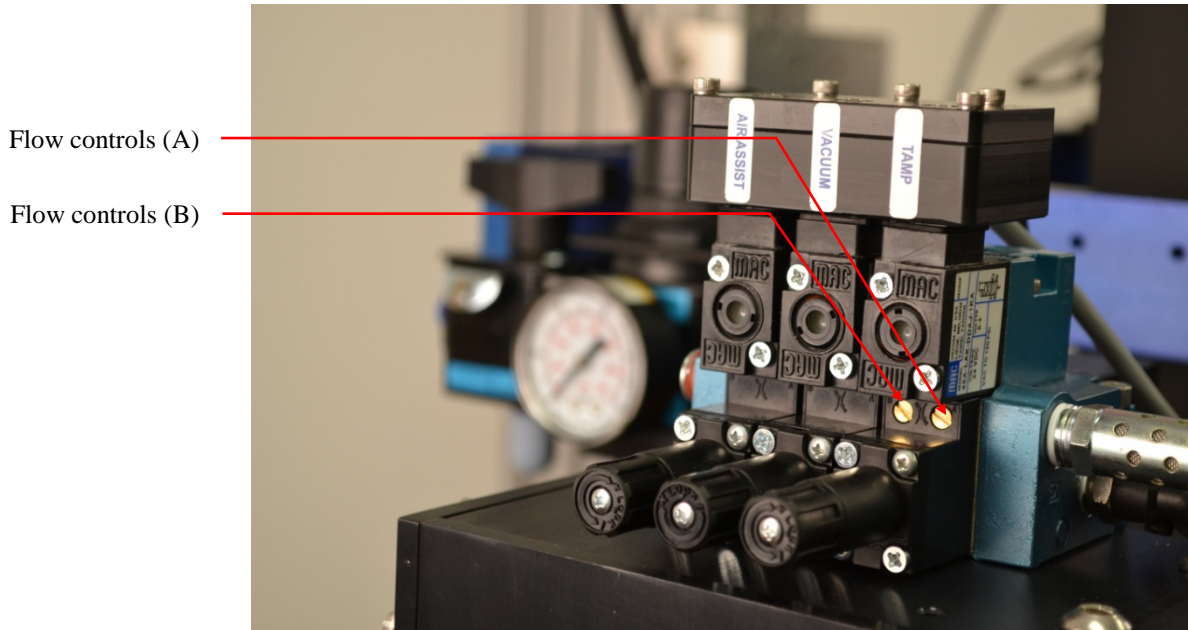

FLOW CONTROLS (Tamp & Corner-Wrap Applications)

Control A: This is used to adjust the speed that the tamp cylinder moves in the upward direction.

Control B: Controls the tamp cylinder in the downward direction.

VACUUM REGULATOR

The vacuum regulator is used to control the vacuum that is used to hold the label to the flag jaws or the tamp pad.

AIR ASSIST REGULATOR

The air assist regulator is used to change the pressure that is applied to the blow tube. The blow tube is below the front edge of the peeler plate and is used to help “push” the label onto the bottom of the tamp pad or the flag jaws.

FLAG REGULATOR (Only present if configured with flag applicator head)

The flag regulator is used to adjust the pressure that the flag jaws apply to the label as it is applied.

Tamp Assembly & Factory Setup

NOTE: PICTURES SHOWN MAY NOT RESEMBLE YOUR MODEL

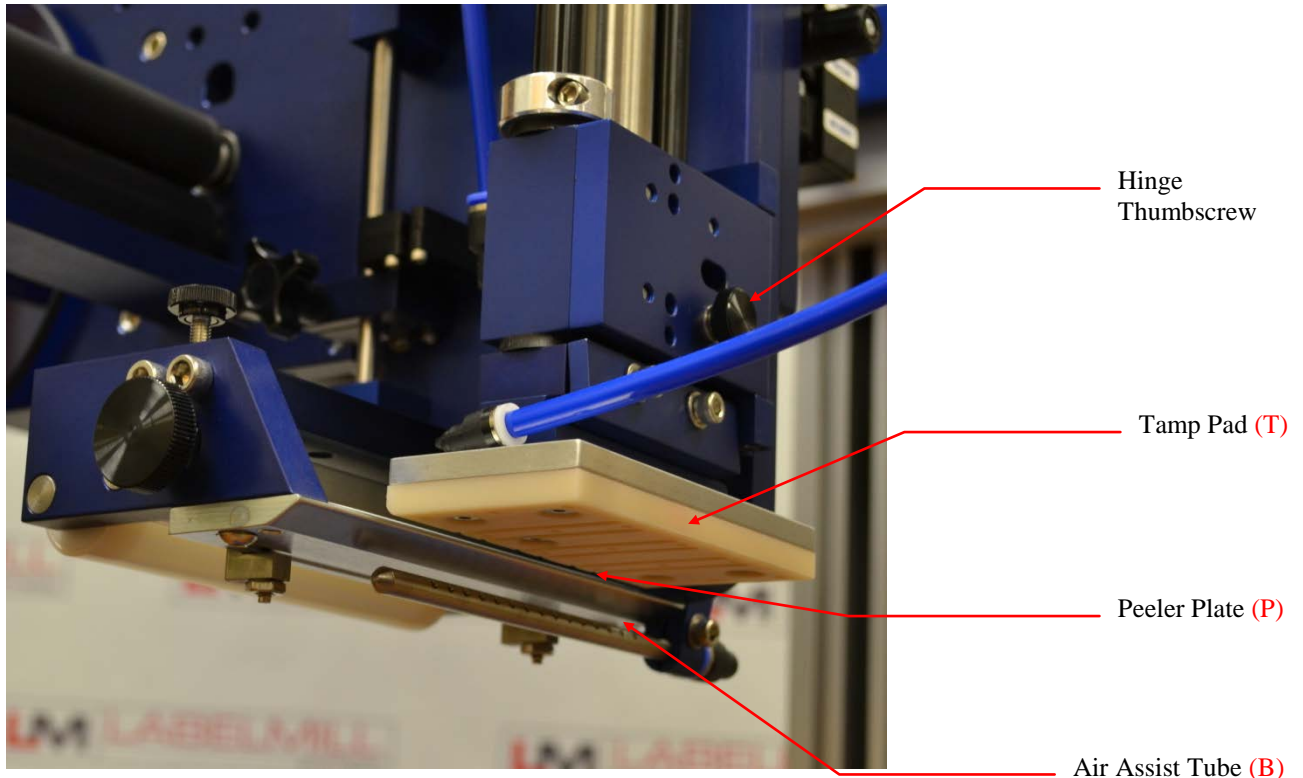

Tamp pad adjustment

1. To adjust the tamp pad (T) in relationship to the peeler plate (P) in the horizontal plain, loosen the (2) button-head screws and move the peeler plate forward or backward in the slots. There should be approximately 0.020" gap between the tamp pad (T) and the peeler plate (P).
2. To adjust the tamp pad (T) in relationship to the peeler plate (P) in the vertical position, loosen the hinge thumbscrew, swing the tamp assembly out, and loosen the (4) cap head bolts that secure the tamp mount assembly in place. Adjust the up or down to achieve the 0.020", tighten the (4) bolts, and secure the tamp assembly in place by tightening the thumbscrew. This adjustment is very important! If this is not adjusted properly, the label will run into the back of the tamp pad (T) and fold or bunch up.

Air assist tube adjustment

1. Adjust the air assist tube (B) so that the small holes aim towards the center of the tamp pad. The air assist tube (B) aids the label to adhere to the bottom of the tamp pad (T). Once the label is "blown" onto the tamp pad (T), it is held there by vacuum.
2. Once the above adjustments are made, adjust the vacuum regulator, the air assist regulator, and the flow controls as necessary.

Note: Too much pressure on the air assist will cause the label to flutter and/or blow off of the vacuum platen.

Flag Assembly & Factory Setup

NOTE: PICTURES SHOWN MAY NOT RESEMBLE YOUR MODEL

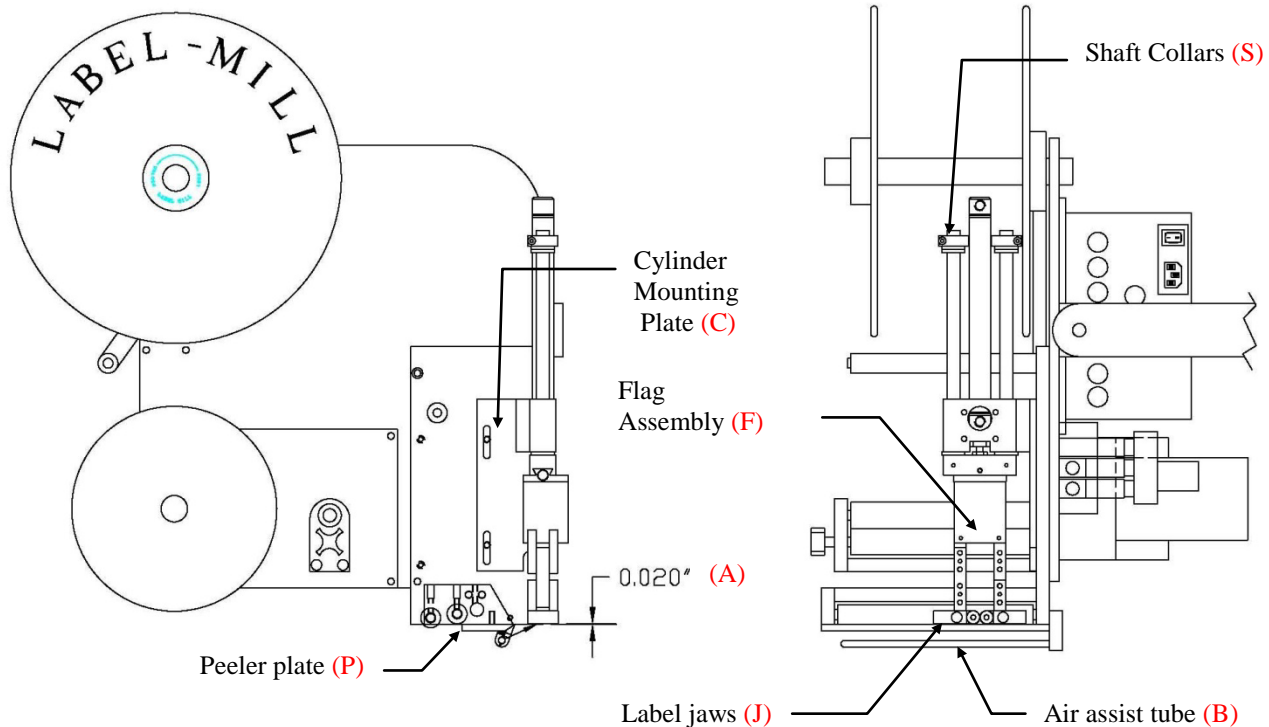

Label jaw to peeler plate clearance and maximum cylinder travel

To adjust the label jaws (J) in relationship to the peeler plate (P), the cylinder mounting plate (C) and the shaft collars (S) must be adjusted accordingly. The cylinder mounting plate (C) is used to adjust the gap between the peeler plate and the label jaws (A). The shaft collars (S), along with the air valves, are used to adjust the label jaws maximum travel.

1. To adjust the label jaws to peeler plate clearance (A), loosen the two button head cap screws and adjust the cylinder mounting plate to reach the desired 0.020" (A) clearance.
2. After this is set, retighten the cap screws. The dimension (A) should now be double-checked to insure proper clearance. This adjustment is very important! If this is not adjusted properly, the label will run into the back of the label jaws (J) and fold or bunch up.

Air assist tube adjustment

1. Adjust the air assist tube (B) so that the small holes aim towards the center of the label as shown by the arrowhead shown above. The air assist tube (B) aids the label to adhere to the bottom of the label jaws (J). Once the label is "blown" onto the label jaws (J), it is held there by vacuum.
2. Once the above adjustments are made, adjust the vacuum regulator, the air assist regulator, and the flow controls.

Note: Too much pressure on the air assist will cause the label to flutter and/or blow off of the vacuum platen.

Synchronous Feed Assembly & Factory Setup

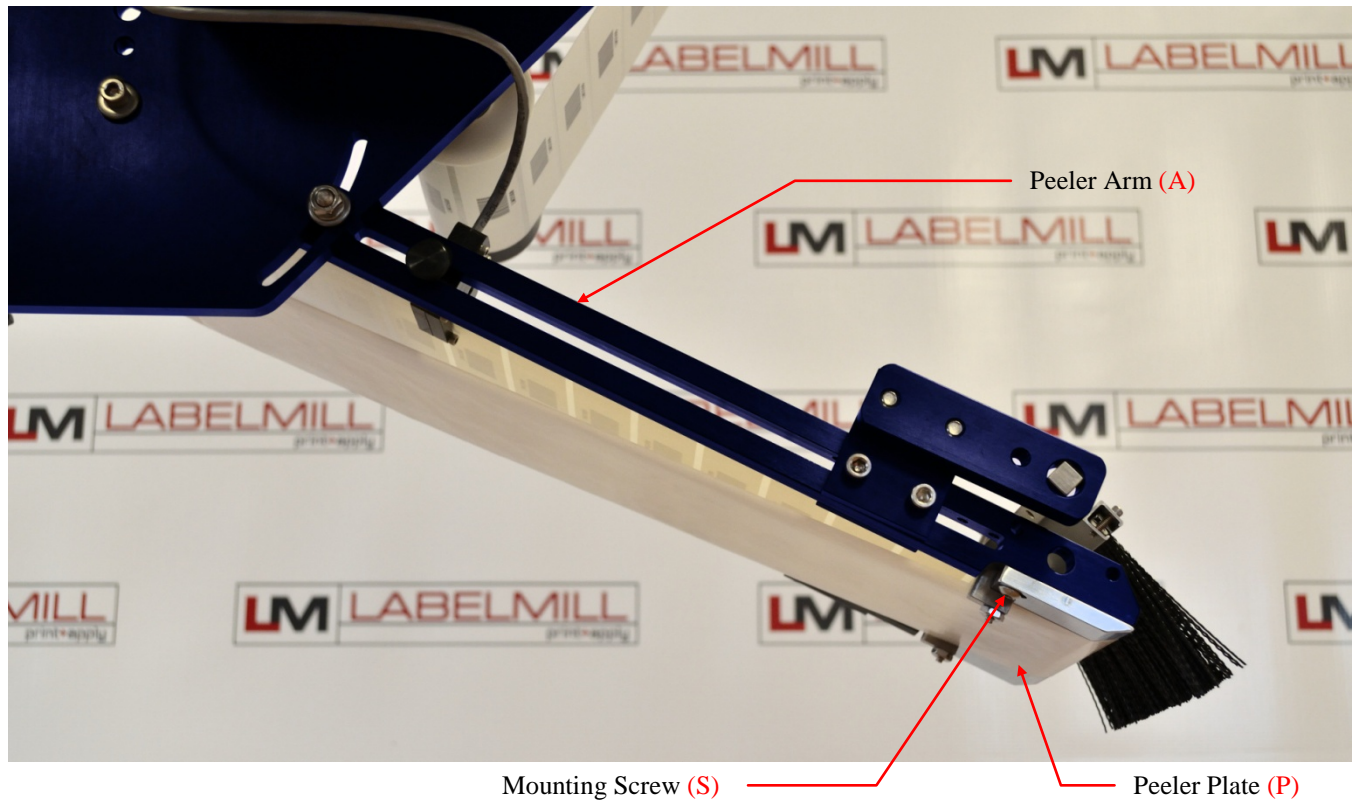

Peeler Plate Adjustment (used to adjust tracking)

1. Loosen the mounting screws (S) and slide the peeler plate (P) in the direction needed to make the label web track in the desired direction.
2. Retighten the mounting screws (S) to secure the peeler plate (P) after adjustments are made.
3. Now that the plate is adjusted, test run the machine to see if the web tracks correctly.

NOTE: If the web tracks towards the back plate, adjust the end of the peeler plate (P) that is closest to the back plate away from the back plate or the opposite end toward the back plate. Adjust the peeler plate (P) in the opposite direction if the web tracks away from the back plate.

SECTION 4

PROGRAMMING AND CONTROL OPERATION

Hand-Held Labeler Interface HLI-112	25
Control Accessory Connections	26
T-52 Photo Eye (System Trigger)	27
System Setup - Programming	28
Programming Flow Chart	31
Key Definitions	41
Set Up of Key Features	42
Quick Start & Manual Setup (Asynchronous Configuration)	43
Input & Output Description	45

HAND-HELD LABELER INTERFACE HLI-112

- The HLI-112 Labeler Interface is used to change system parameters, clear system faults, and display the current system status. The "Total" counter will be displayed when the interface is on the "home" screen, and no faults are present.

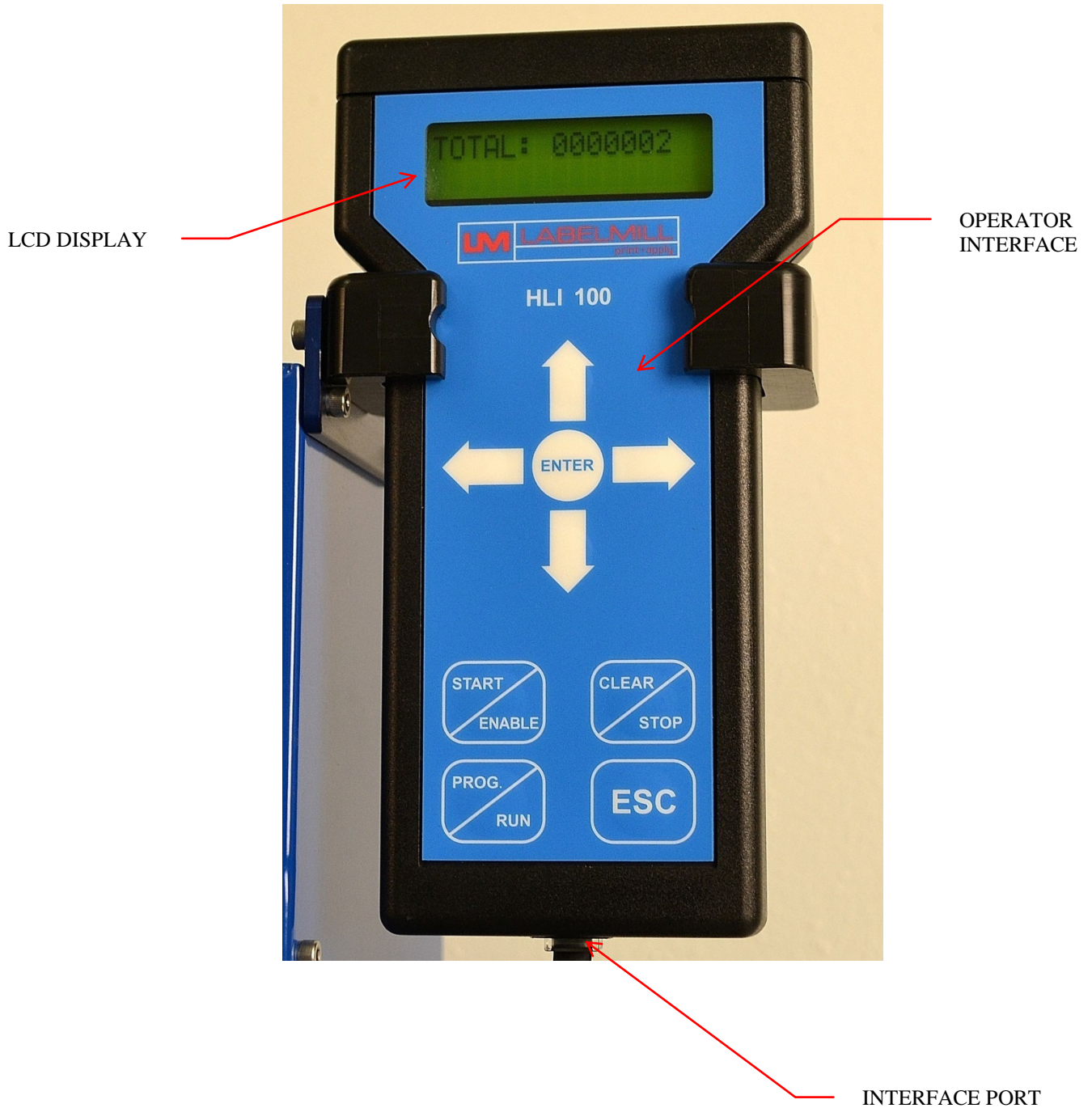

ACCESSORY CONNECTIONS

CONTROL BOX LOCATED ON BACK OF LABELER BACK PLATE

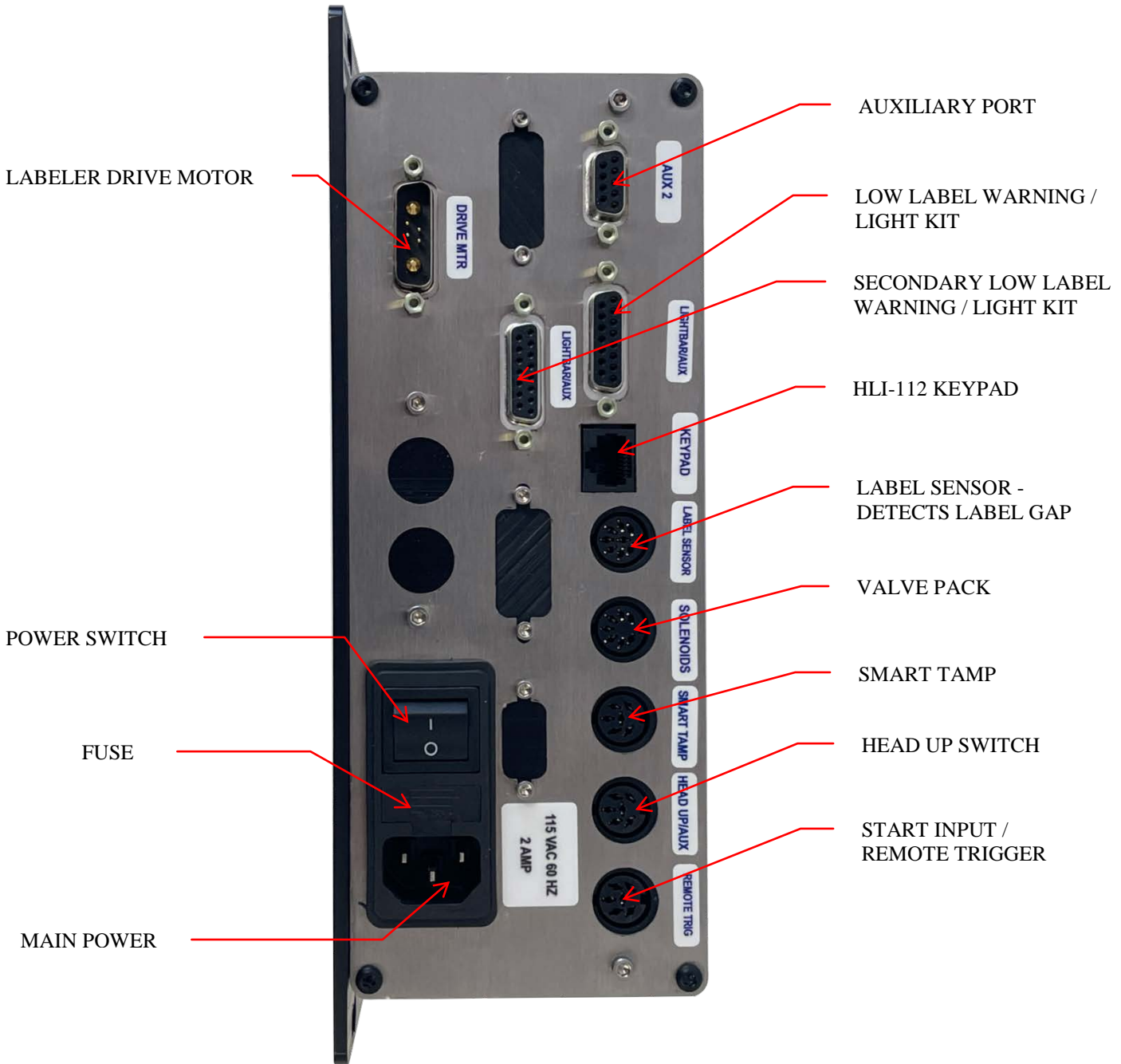

T-52 EXTERNAL PHOTO-EYE

- The T-52 External Photoeye is used to automatically trigger the labeling system. The photoeye needs to be mounted properly to provide a consistent trigger signal, and can be adjusted to properly sense the presence of a product. Additional options are available.



SYSTEM SETUP

PROGRAMMING

All programming is performed via the **HLI-112** input device. All programmed settings are backed in nonvolatile memory and are not lost when the unit is powered off.

Upon power up of the control, the screen will display *MODEL NUMBER & REVISION* of the HLI-112 and then the *MODEL NUMBER & REVISION* of the labeler control. After this, the screen will now display the counter, *TOTAL XXXXXXXX*.

• KEY FUNCTIONS:

“**PROG**” PROGRAM KEY IS USED TO:

1. **Enter and exit** the program menu.

“**ENTER**” KEY IS USED TO:

1. Access or “Enter” the selected “PROGRAM BLOCK”. (example PRODUCT SENSOR or TAMP SETUP)
2. Access or “Enter” the **data selection/options** line (bottom line of display) of the “PROGRAM BLOCK” **Sub Menus**.
3. Store the selected data.

UP / DOWN ARROW KEYS ARE USED TO:

1. Scroll up & down through the primary menu “PROGRAM BLOCKS” . (Header name)
2. Scroll **sub menus** inside of “PROGRAM BLOCKS”. (top line of display while **IN** a “PROGRAM BLOCKS”)
3. Increment and decrement programmable values.
4. Select different display views while in the “RUN” mode.

Left / Right ARROW KEYS ARE USED TO:

1. Move the “up caret” left or right when programming a value.

START / ENABLE KEY:

1. Start key will initialize the application cycle.
2. Enable key will “Enable” the drive after it has been disabled.

CLEAR / STOP KEY:

1. Stop key will abort the cycle only when not in the program menu.
2. Clear key will delete stored values while in the edit mode.
3. Clear key will disable the drive.

ESC (escape) KEY:

1. Will back out of the sub programming menu without saving changes.

Note: Press the Prog/Run key on the HLI-112 device to access the program menus, as described below

- **PASSWORD**

The PASSWORD is used to lock the menus of the control. This option is used to prevent unauthorized access to variable data. When shipped from the factory, the password is to 7074 and NO MENUS are locked. The factory password cannot be changed.

- **AUTO SET GAP** *****NO LONGER USED IN SYSTEMS MANUFACTURED AFTER 2020*****

The AUTO SET GAP function is used to set label sensor values. (Note that when using a Clear label detector the sensor values are not relevant) The label speed (IPM) can be set to fine tune this option. It is recommended to leave the IPM set to 300 or set it at the current application speed.

- **PRODUCT SENSOR**

This is an external device that when "activated" starts the application cycle.

PROGRAMMABLE BLOCKS:

- Product Delay – Delays the application of the label (x) seconds after the sensor has been activated.
- Sensor Trigger – Programs system to be activated at the leading or trailing edge of the trigger signal.
- On Debounce - Programs how long (seconds) a trigger signal must be received to activate system.
- Off Debounce - Used to ignore trigger signals (in seconds) after a cycle has completed.
- Multiple Feed – Programs how many system cycles occur with a single trigger signal.
- Interval Delay – Amount of time in seconds between multiple fed labels. Note: Active with quantity 2+

- **TAMP SETUP**

This is used to adjust the different variables related to the tamp cycle.

PROGRAMMABLE BLOCKS:

- Tamp Duration – Used to adjust the time that the tamp cylinder valve is actuated.
- Flag Duration – Used to adjust the time the flag jaws are held open after label application.
- Head Up Limit Switch – Type: **normally open**-standard, none
- Head Up Debounce – Debounce is used to allow time for the tamp cylinder to settle on return.
- Vacuum Release – Used to release label when tamping on light products.
- Vacuum Delay On – Used to reduce label flutter when feeding large labels onto the vacuum platen.
- Tamp Sync - Used for "Normal" or "Reverse" Tamp signal operation.

- **LABEL SPEED**

PROGRAMMABLE BLOCKS:

- Label Speed – Used to control the speed that the label is fed through the system.
- Label Acceleration - Used to control how fast the motor reaches the programmed feed speed.

- **COUNTER**

Used to reset the internal Total Counter or Batch Counter of the control. Batch preset used to inhibit system after programmed batch counter limit has been reached.

• LABEL SENSOR

Provides the ability to select different label sensor types and also set the parameters within these sensor types.

PROGRAMMABLE BLOCKS:

I-Mark/Gap/CLR – Used to select type of label sensor. "Clear" setting used for standard applications.

Manual Set Gap – Automatically sets the emitter voltage when sensor is held on gap between labels.

- Not used in systems manufactured after 2020.

Gap Threshold – Voltage differential needed to trigger control. (sensitivity)

Label Length - Used to program the length of the label being used.

Label Gap Length - Used to program the length of the gap between each label.

Label Stop Position – Electronically adjusts label stop position in reference to the peeler plate point.

Missing Label Detect - Turns on the missing label alarms and enables the auto advance feature.

• ENCODER

This is an external device that when activated measures conveyor speed and matches the label feed speed.

PROGRAMMABLE BLOCKS:

- On/Off - Used to turn the external encoder option on or off.
- Trigger Distance - Used to apply the label a certain distance away from the trigger point.
- Trigger Mode - Used to set the mode to Trigger Distance or Product Delay.
- Encoder Lines per Inch - Tells how many pulses the encoder will count with one inch of travel.
- Show Conveyor Speed - Shows live reading of encoder feedback. (conveyor speed)

• CYCLE TYPE

Cycle Type determines the application type and sequence in relation to the label feed.

PROGRAMMABLE BLOCKS:

- No Tamp
- Tamp Before Feed
- Tamp After Feed
- Blow Before Feed
- Blow After Feed
- Clam Shell Before
- Clam Shell After

• PRINTER SETUP

Used to control the system operation when an external printer is connected to the applicator.

Print a Label - Signals External Printer to print a single label. (Press Left Arrow Key)

Cycle No Print - Cycles applicator system without signaling the printer to print a label. (Press Right Arrow Key)

Printer Enable - On/Off

Print Repeat - On/Off

Printer Ready Fault Timer - Programmable timer for monitor of End of Print Signal & Fault Output.

• JOB STORAGE

Used to store frequently used settings pertaining to different labeling jobs.

PROGRAMMABLE BLOCKS:

Read a Job – Restores saved job. (1-6)

Write a Job - Saves settings to specified job. (1-6)

Delete a Job - Deletes the saved job file. (1-6)

- **DEFAULT SETTINGS** - Selecting this option will return the controller to the factory default settings.

- **I/O STATUS** - Displays the status of the inputs and outputs.

PROGRAMMING FLOW CHART

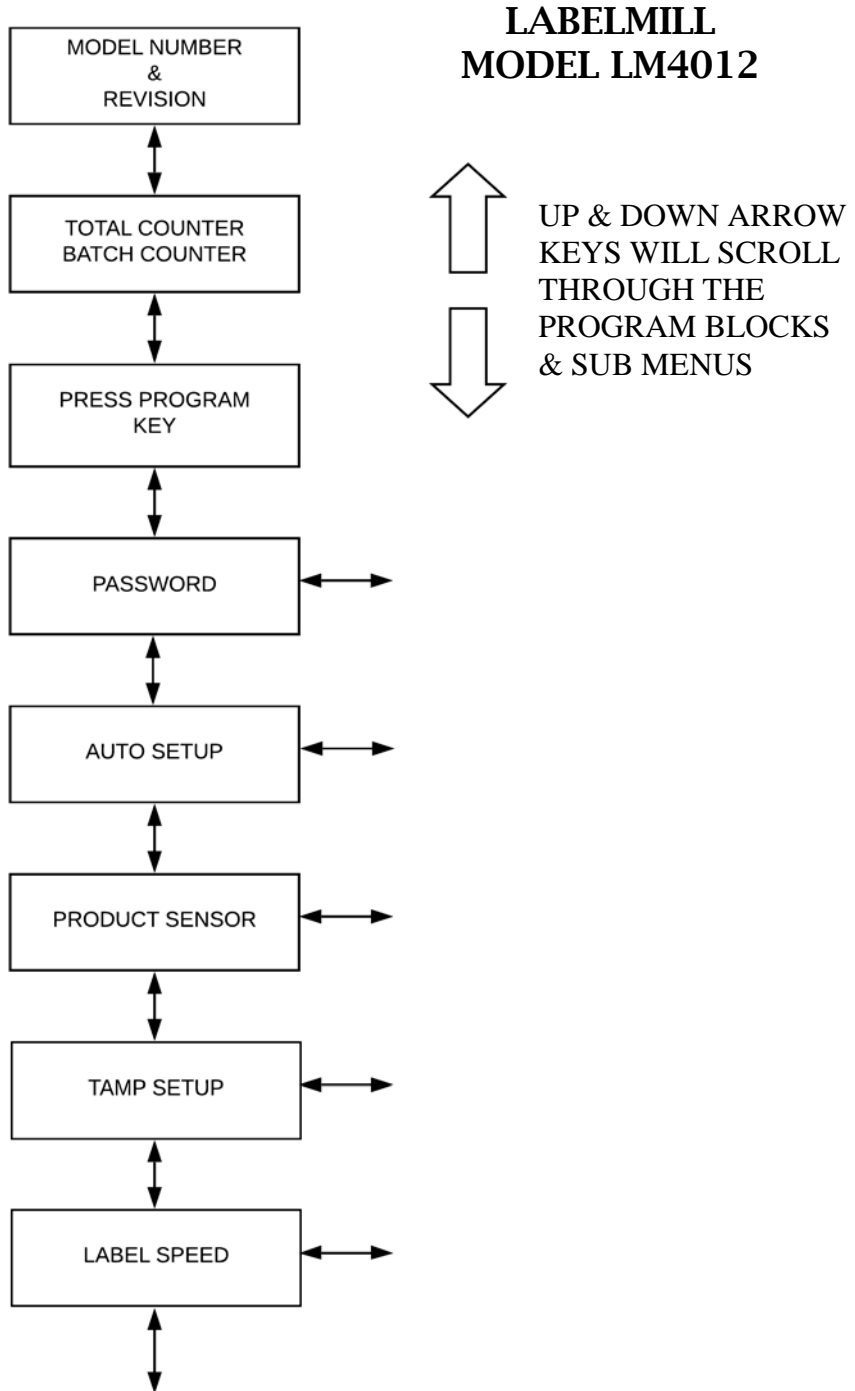

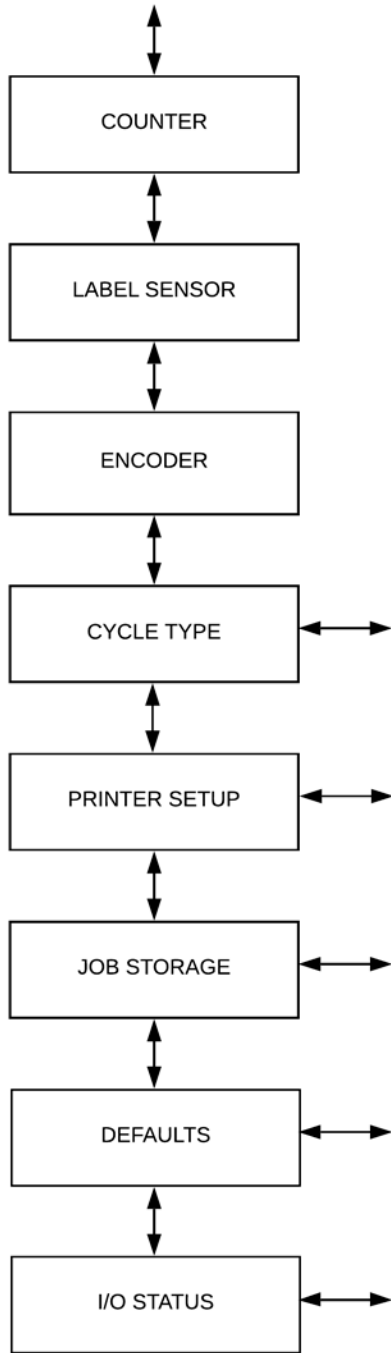

MAIN DISPLAYS

The following flow charts show the main display menus and sub-menus. To access the program menu, press the Prog / Run key on the HLI-112 input device.

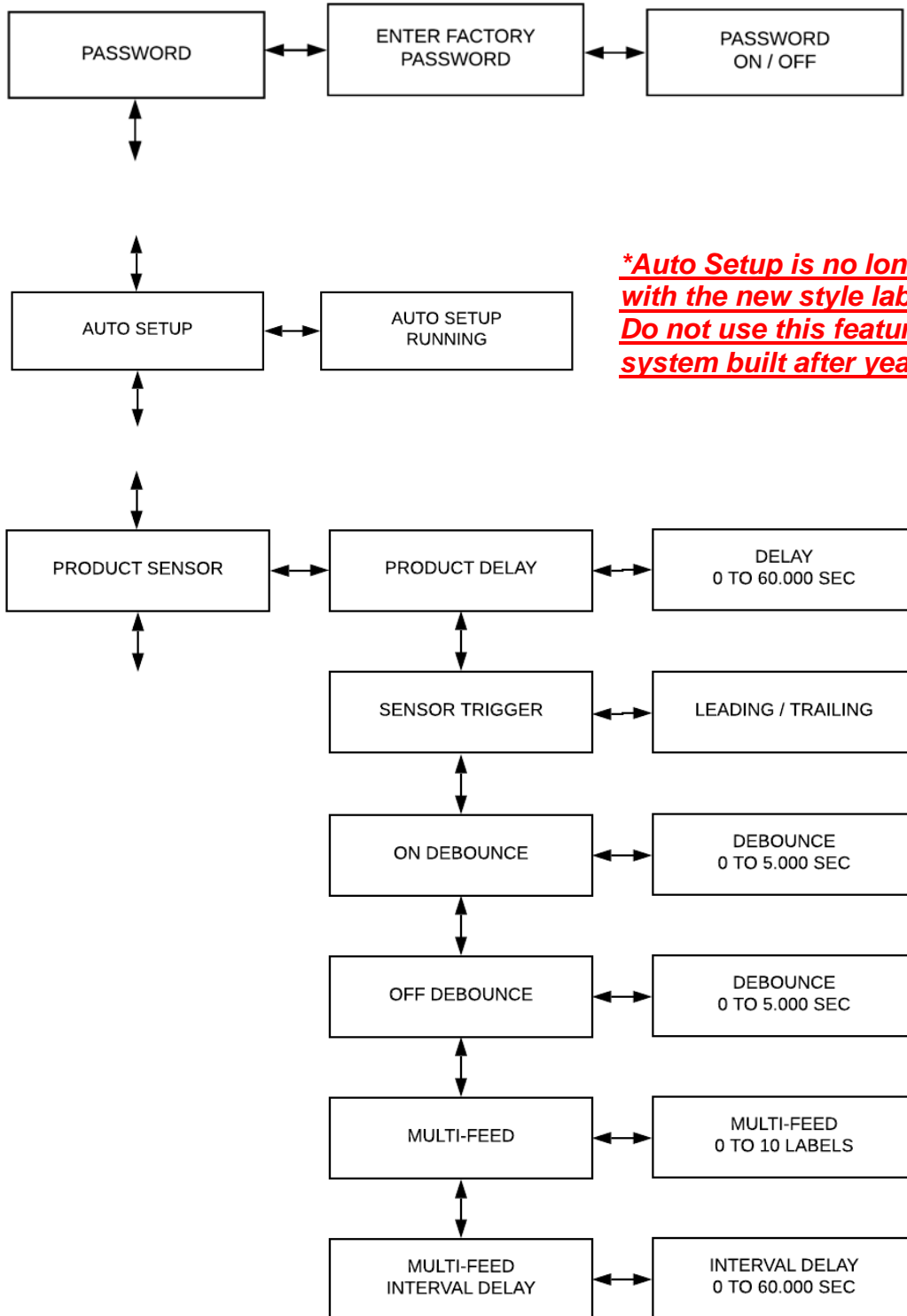

***Auto Setup is no longer used with the new style label sensor. Do not use this feature with any system built after year 2020.**

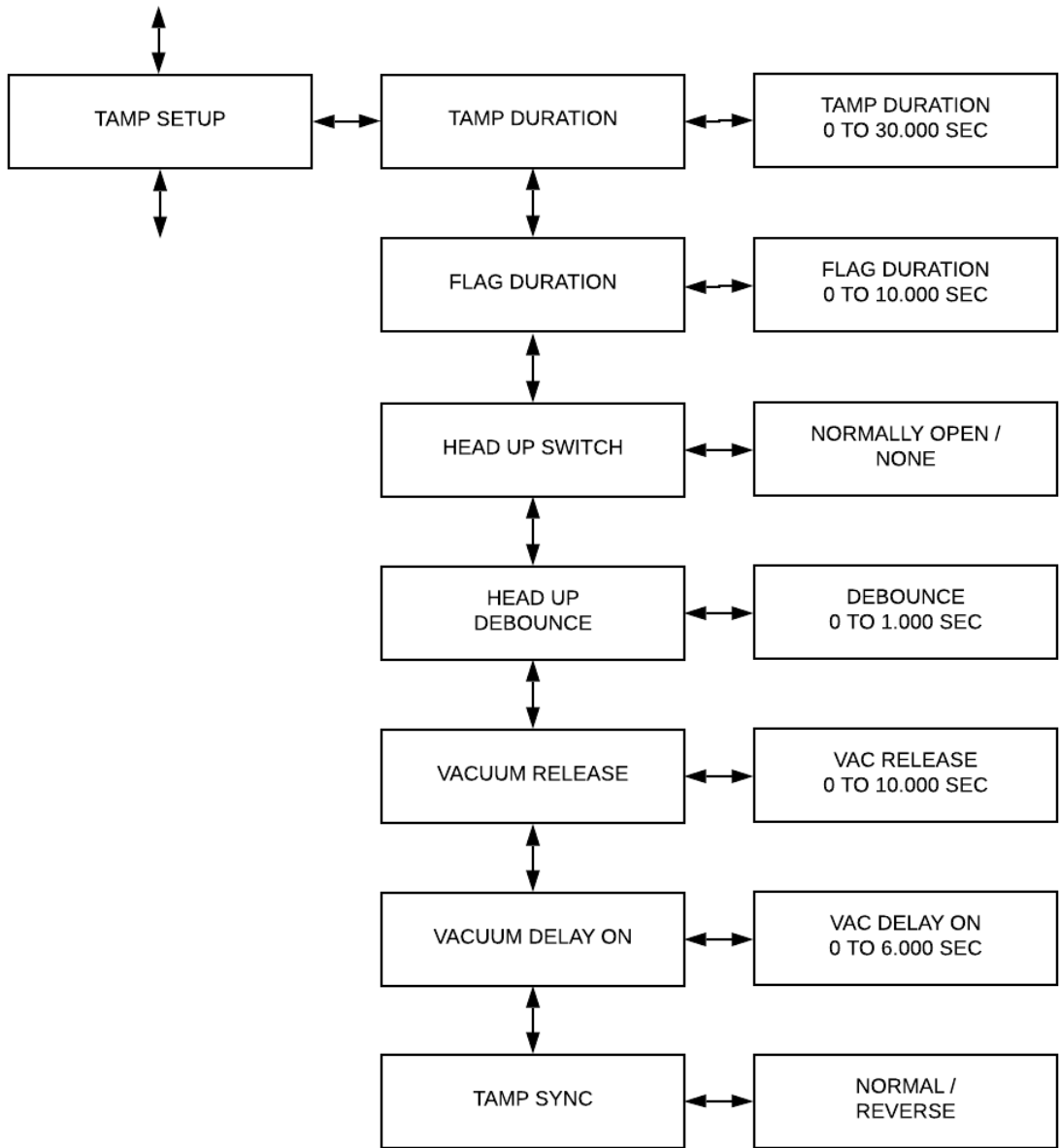

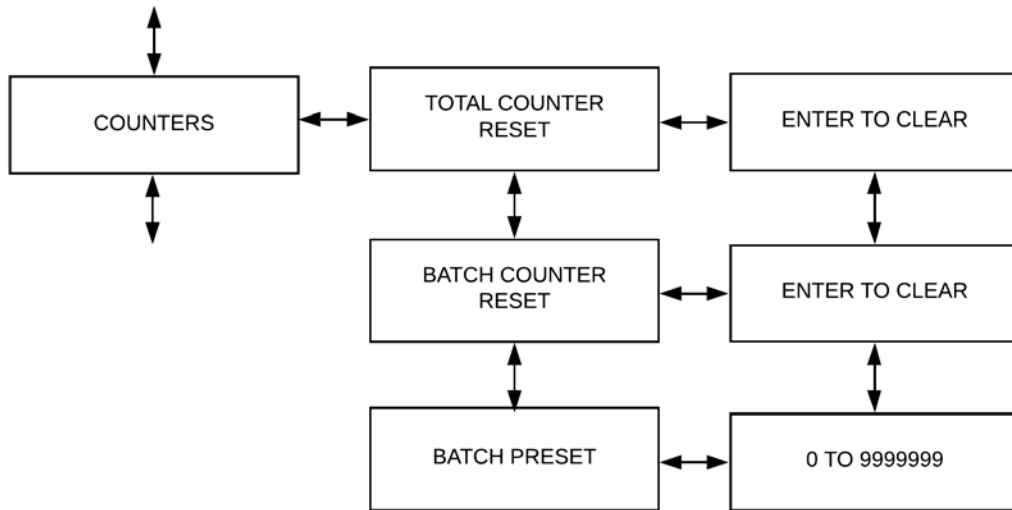
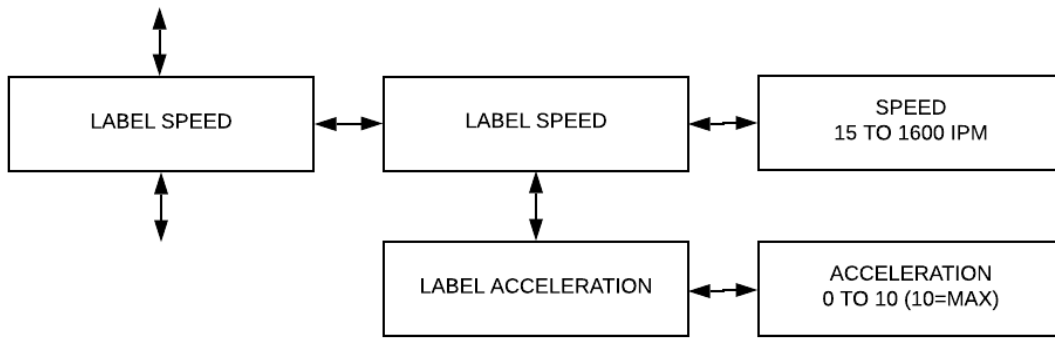

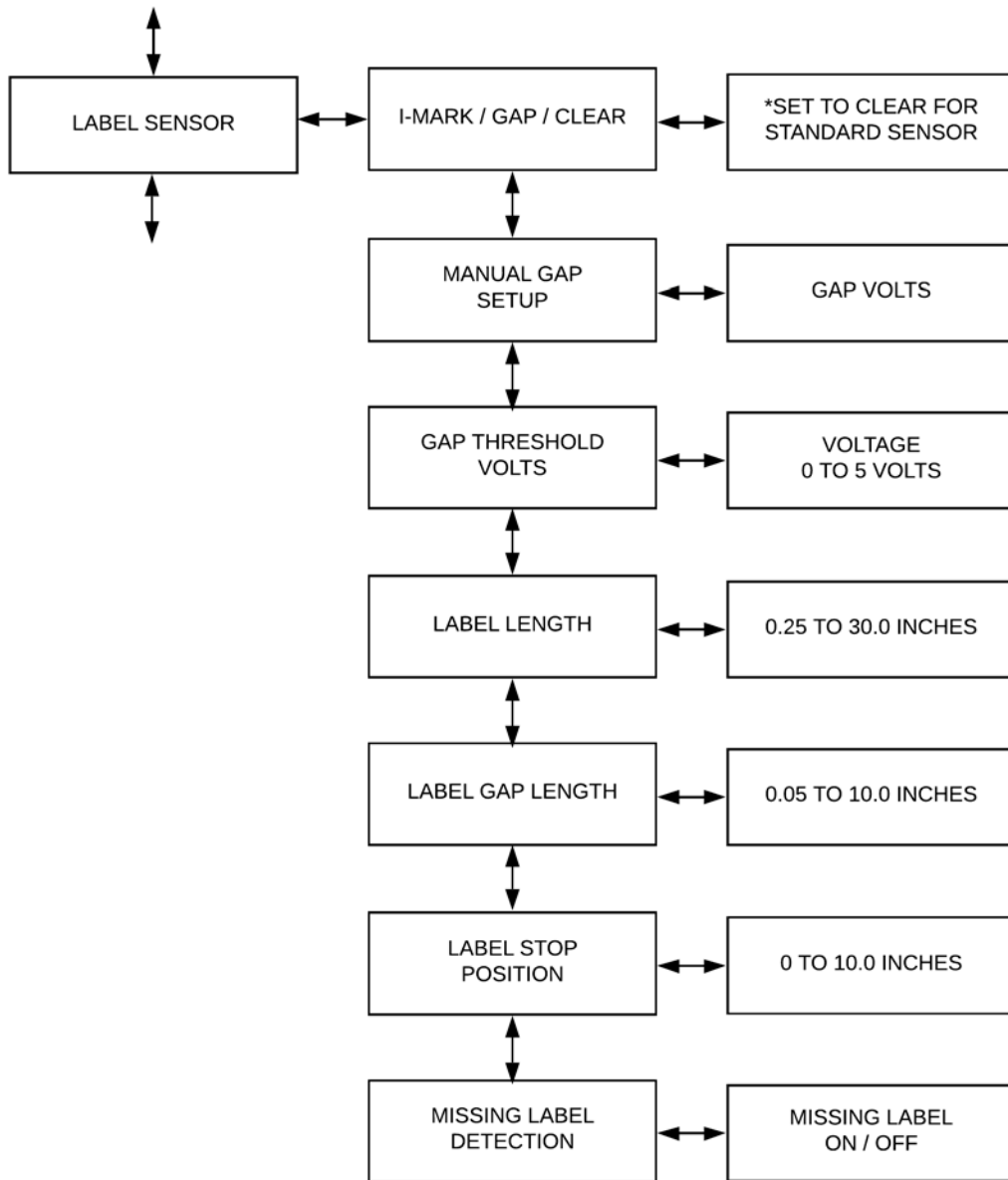

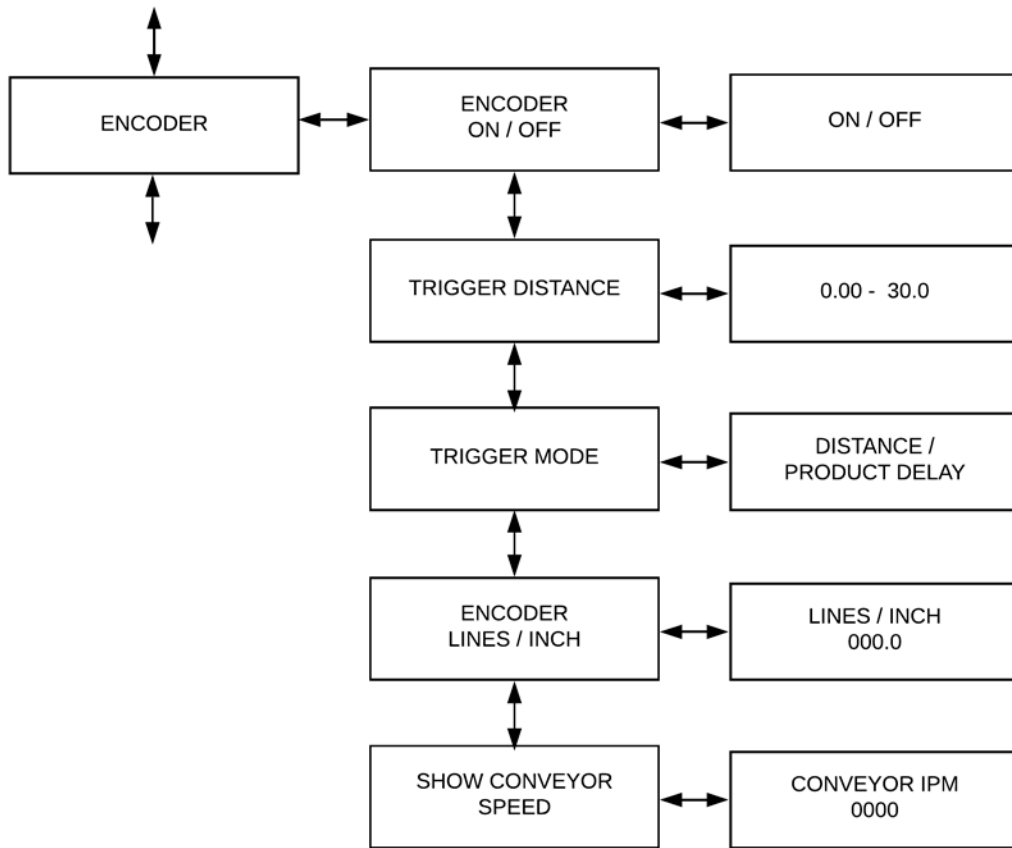

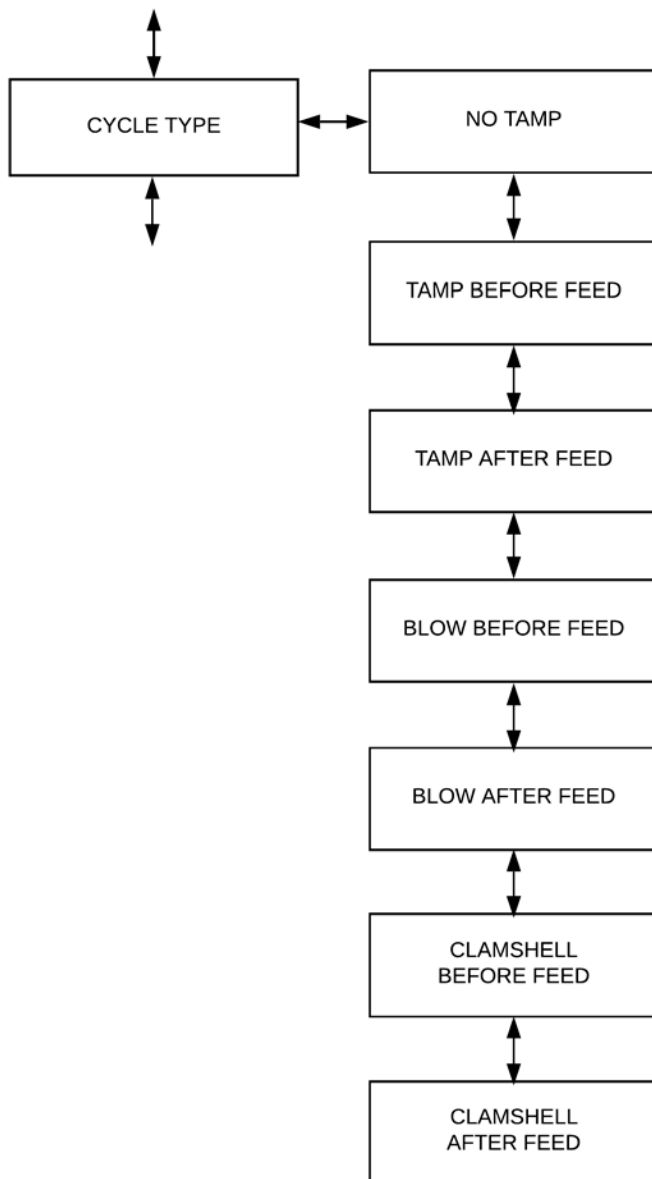

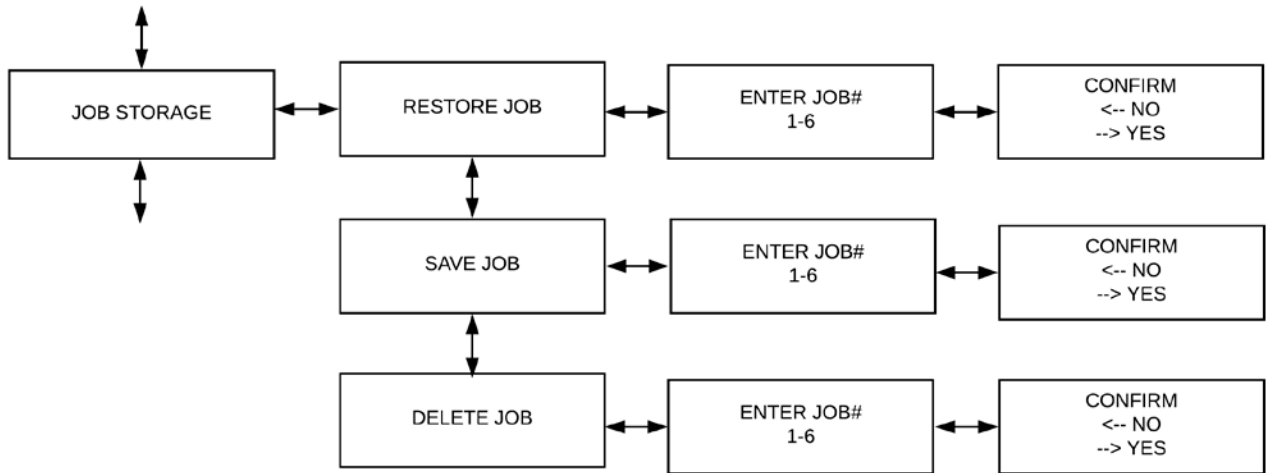
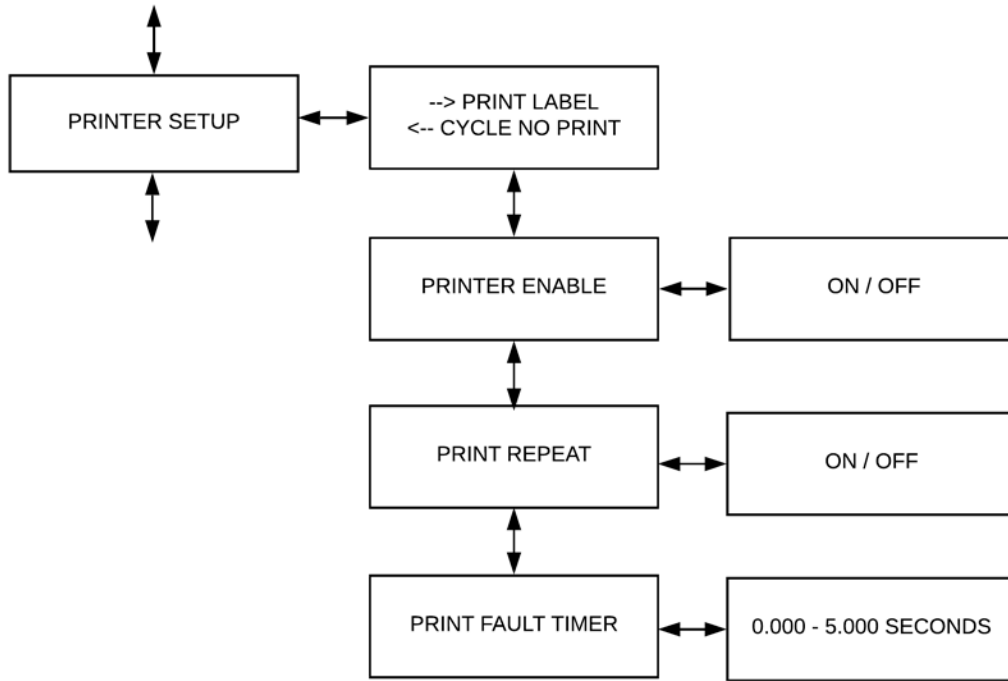

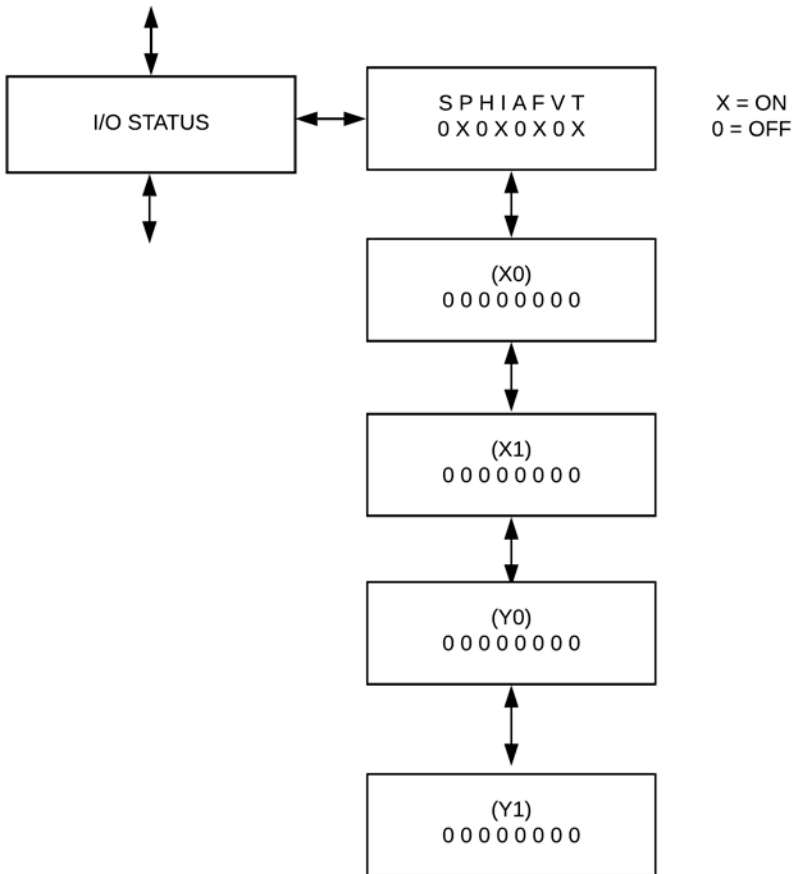
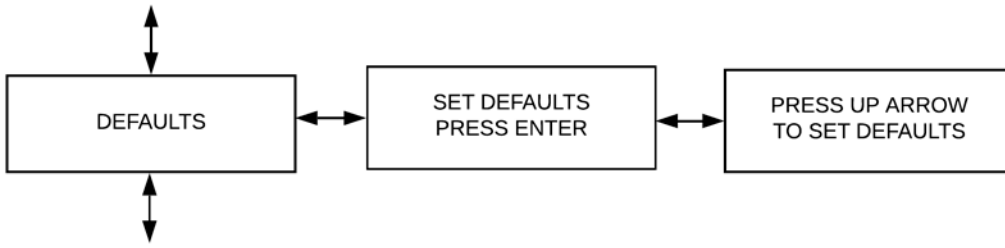

KEY DEFINITIONS

- **ASYNCHRONOUS OPERATION** – The term “ASYNCHRONOUS OPERATION” is used because the speed of the applicator motor (label speed) does not necessarily match the speed of the product conveyor. In other words their speeds are set independently of one another and have NO interrelation. An example of this is when the applicator is configured in the tamp mode.
- **SYNCHRONOUS OPERATION** – The term “SYNCHRONOUS OPERATION” is used because the speed of the applicator motor (label speed) is matched to the speed of the product conveyor.
- **PRODUCT DELAY** is used to electronically move the placement of the label on the product. Product delay will move the label placement in time (00.000) seconds. Because the product delay feature utilizes time, the speed of the product **MUST** remain constant. A product traveling at a higher velocity will travel further in a given time, thus effecting the placement of the label.

QUICK START GENERAL SETUP

1. Inspect applicator system and verify all cables are installed properly.
2. Web system with labels.
3. Turn power switch on.
4. Press “PROG” key to enter setup menu.
5. Use up or down arrows to reach "CYCLE TYPE" menu.
6. Press “ENTER” key on "CYCLE TYPE".
7. Select "No Tamp" option and press "ENTER" key to save.
8. Use up or down arrows to reach "LABEL SENSOR" menu, and press "ENTER" key.
9. Use up or down arrows to reach "I-MARK / GAP / CLEAR" menu, and press "ENTER" key.
10. Use up or down arrows to reach "CLEAR" option, and press "ENTER" key.
11. Press "PROG" key to exit the programming menu and return to main screen.
12. Cycle system twice by pressing the “START” key.
13. Observe label speed and change if required.
14. Manually move the label sensor if needed so that the label stops flush with the peeler plate tip.

System is now ready for set up of advanced features & options.

SETUP OF KEY FEATURES

• PRODUCT DELAY

PRODUCT DELAY is used to electronically move the placement of the label on the product. Product delay will move the label placement in time (00.000). Because the product delay feature utilizes time, the speed of the product MUST be constant and consistent.

1. Set basic applicator up first, refer to quick setup.
2. Ensure that applicator is operating properly before starting this procedure.
3. Set Product delay to 00.000
4. Start system and apply label at the desired speed.
5. Check the placement of the label on the product.
6. Measure the OFFSET of the label placement. Note: A label CAN NOT be advanced on the product ONLY moved “back” since the applicator can only delay the product signal.
7. Apply a small delay to the product delay or if too great, it may be necessary to physically move the product switch. Keep product delays to a minimum for best results.
8. Operate system again and measure offset.
9. Apply a small delay to the product delay or reduce if too much.
10. Test again; repeat if necessary until label is in proper registration.

• LABEL STOP POSITION

LABEL STOP POSITION is used to electronically move the stop position of the label on the applicator ONLY. The setup below describes how to use the LABEL STOP POSITION. The STOP DELAY is used to delay the “stop” position of the label relative to the peeler plate. If a “time” is entered into the STOP DELAY, the label will advance further out on the peeler plate.

1. Set basic applicator up first, refer to quick setup.
2. Operate applicator at desired label speed.
3. Manually move the label sensor to adjust the label stop position or the label stop position can also be electronically adjusted using the LABEL STOP POSITION. The proper stop position will be with the leading edge of the label stopping flush with the tip of the peeler plate. If this option is used the distance must be kept to a minimum.
4. Operate the applicator again at the same speed.
5. Does the label stop at the tip of the peeler plate? Yes = task complete NO = continue
6. Enter a small “time” in the STOP DELAY.
7. Operate system at the same speed again and check label offset.
8. Make the necessary adjustments to the STOP DELAY.
9. Test again; repeat if necessary until label is in proper registration to the peeler plate tip.

Note: The STOP DELAY distance CAN NOT be greater than half the length of the label. If the STOP DELAY time is too large, inconsistent and double label feeding will occur.

HOW TO SET UP AN ASYNCHRONOUS APPLICATION

TAMP SETUP

Determine the following and select it in the software

1. Type of application mode - MENU "CYCLE TYPE"
2. Tamp before or after feed (before feed is standard)
3. Enter a value in the tamp duration (start with 00.200) - MENU "TAMP SETUP"
4. Set head up limit switch, normally open is standard - MENU "TAMP SETUP"
5. Set Label Speed to appropriate value - MENU "LABEL SPEED"
6. Adjust position of Label Sensor so that label stops at edge of peeler plate.

FLAG SETUP

Determine the following and select it in the software

1. Type of application mode - MENU "CYCLE TYPE"
2. Tamp before or after feed (before feed is standard)
3. Enter a value in the tamp duration (start with 00.200) - MENU "TAMP SETUP"
4. Enter a value in the flag duration (start with 00.200) - MENU "TAMP SETUP"
5. Set head up limit switch, normally open is standard - MENU "TAMP SETUP"
6. Set Label Speed to appropriate value - MENU "LABEL SPEED"
7. Adjust position of Label Sensor so that label stops at edge of peeler plate.

BLOW SETUP

Determine the following and select it in the software

1. Type of application mode - MENU "CYCLE TYPE"
2. Blow before or after feed (before feed is standard)
3. Enter a value in the tamp duration (start with 00.100) - MENU "TAMP SETUP"
4. Set head up limit switch, NONE is standard - MENU "TAMP SETUP"
5. Set Label Speed to appropriate value - MENU "LABEL SPEED"
6. Adjust position of Label Sensor so that label stops at edge of peeler plate.

CLAMSHELL FLAG SETUP

Determine the following and select it in the software

1. Type of application mode - MENU "CYCLE TYPE"
2. Clamshell before or after feed (before feed is standard)
3. Enter a value in the tamp duration (start with 00.200) - MENU "TAMP SETUP"
4. Enter a value in the flag duration (start with 00.200) - MENU "TAMP SETUP"
5. Set head up limit switch, normally open is standard - MENU "TAMP SETUP"
6. Set Label Speed to appropriate value - MENU "LABEL SPEED"
7. Adjust position of Label Sensor so that label stops at edge of peeler plate.

HOW TO APPLY MULTIPLE LABELS TO A SINGLE PRODUCT

Product delay is used to electronically move the placement of the **FIRST** label on the product. Product delay will move the label placement in time (00.000). Because the product delay feature utilizes time, the speed of the product **MUST** be constant and consistent. This section will explain how to apply more than one label to a single product with a single start signal. **MULTIPLE FEED** will allow you to select how many labels to be applied.

1. Set basic applicator up first, refer to quick setup
2. Ensure that applicator is operating properly before starting this procedure.
3. Set Product delay to 00.000
4. Start system and apply label at the desired speed.
5. Check the placement of the label on the product.
6. Measure the **OFFSET** of the label placement. Note: A label **CANNOT** be advanced on the product **ONLY** moved “back” since the applicator can only delay the product signal.
7. Apply a small delay to the product delay or if too great, it may be necessary to physically move the product switch. Keep product delays to a minimum for best results.
8. Operate system again and measure offset.
9. Apply a small delay to the product delay or reduce if too much.
10. Test again; repeat if necessary until label is in proper registration.
11. Go to **MULTIPLE FEED** in **PRODUCT SENSOR** menu and set the number of labels to be applied to the product.
12. Set the Distance between each label entering a time (0.000) into “**INTERVAL DELAY**”.
13. Test the placement of the labels and adjust as necessary. Note: The spacing between each label will be equal. With this feature the space between labels **cannot** be set individually.
14. Note: **TRAILING EDGE TRIGGER** will **NOT** work with this feature!
15. Note: Product speed fluctuations can effect label placement.
16. Turn back on any options that may have been disabled for setup of this particular feature.

DESCRIPTION OF I/O

All user inputs and outputs are “**SINKING**” type.

Status display legend.

INPUTS				OUTPUTS			
S	P	H	Y	A	F	V	T
SMART TAMP	PRODUCT SENSOR	HEAD UP TAMP SENSOR	AUX OUT #1	AIR ASSIST SOL	FLAG SOL	VACUUM SOL	TAMP SOL

Control Interface Connections Shown Below

REMOTE TRIGGER CONNECTOR (PRODUCT SWITCH)	P7 PIN #	I/O	I/O Monitor Address
+24vdc	1		
+24vdc	2		
Trigger Input #1	3	Input	X0.0
Two Hand Start AUX1	4	Input	X0.1
24v Common	5		
24v Common	6		
Shield			

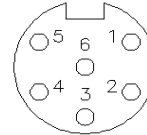

HEAD-UP / AUX IN	P8 PIN #	I/O	I/O Monitor Address
+24vdc	1		
+24vdc	2		
Head – Up/ Index Dwell	3	Input	X0.2
RM Part Present / Smart Tamp	4	Input	X0.3
24v Common	5		
24v Common	6		
Shield			

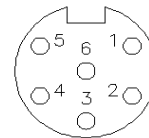

SMART TAMP	P2 PIN #	I/O	I/O Monitor Address
+24vdc	1		
+24vdc	2		
2 nd Trigger / Pre-Print AUX1	3		X0.1
Smart Tamp	4		X0.3
24v Common	5		
24v Common	6		
SHIELD			

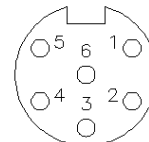

TAMP SOLENOIDS	P6 PIN #	I/O	I/O Monitor Address
Aux Output #2 / Tamp Slide / Powered Label Platen	1	Output	Y1.7
+24 Volt	2		
No connection	3		
Air Assist Sol 24vdc	4	Output	Y0.0
Vacuum Sol 24vdc	5	Output	Y0.2
Tamp Sol 24vdc	6	Output	Y0.3
Flag Sol 24vdc	7	Output	Y0.1
Shield			

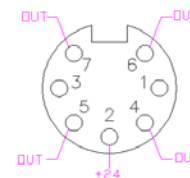

WEB SENSOR (LABEL)	P4 PIN #	I/O	I/O Monitor Address
Clear Label Detector	1	Input	X0.4
24v Common	2		
(+5vdc) LED	3		
Take up output	4	Output	Y1.3
Logic Gnd	5		
Sensor Emitter (+)	6		
Sensor Collector (-)	7		
+24vdc	8		
Shield			

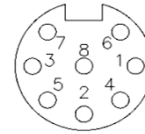

HMI RJ Conn	P3 PIN #	Jumpers
422RX+ (TXB)	1	
422RX- (RXB)	2	
	3	
	4	
24V Common	5	
+24vdc	6	
422TX+	7	
422TX-	8	

Light Bar/Auxiliary Connector 1 & 2 DB-15 Female	P10 Pin #	I/O	I/O Monitor Address	
+24vdc	1			
+24vdc	2			
24 Com	3			
24 Com	4			
Low Label In	5	I	X0.5	
ERROR LITE (Red Light)	6	O	Y0.6	On=GREEN Off=RED
LOW LABEL (Yellow Light)	7	O	Y0.7	
Run Status Ok (Green Light)	8	O		Green = /Red
Tamp Sync Out	9	O	Y1.1	
Inhibit In	10	I	X0.6	
Reprint / Aux Input #2	11	I	X0.7	
Aux Input #3 / Slide Home Input	12	I	X1.1	
Aux Input #4 / Feed Error Input	13	I	X1.2	
Applicator In Cycle Output (Applicator Busy)	14	O	Y1.2	
Batch Done Aux Output #1	15	O	Y1.6	

Serial Plus Port / RM Stepper Motor DB9 Female	P11 PIN #	I/O	I/O Monitor Address
SHIELD	1		
+485 RS232 XMIT (port D) to motor	2		
-485 RS232 RECV (port D) to motor	3		
24C	4		
24C	5		
Tamp Slide / Aux Output #2 High current	6	O	Y1.7
REPRINT / Aux Input #2	7	I	X0.7
+24	8		
+24	9		

Conveyor Encoder Interface DB9 Female Male	P14 PIN #	I/O Monitor Address
A+	1	I
A-	2	I
B+	3	I
B-	4	I
+5V	5	
GND	6	
Shield	7	
No Connection	8	
No Connection	9	

Printer Interface 14 pin Centronix	P9 PIN #	I/O	I/O Monitor Address
Paper End	1	Input	X1.3
Printer Ground	2		
Ribbon End	3	Input	X1.4
Printer Error	4	Input	X1.5
Print Start	5	Output	Y0.4
Print End	6	Input	X1.6
Reprint	7	Output	Y0.5
	8		
ONLINE (Sato Only) (Zebra Data Ready)	9	Input	X1.7
Ribbon Near End	10	Input	X1.0
	11		
	12		
+5vdc From Printer	13		
	14		
Shield			

AUX 2 Auxiliary Connector 3rd DB-15 Male	P13 PIN #	I/O	I/O Monitor Address	
AUX 232 TXC Port C	1	O		RS232 Output
GND	2			
GND	3			
Batch Done Aux Output #1	4	O	Y1.6	
REPRINT / Aux Input #2	5	I	X0.7	
Aux Input #4 / Feed Error Input	6	I	X1.2	
+24V	7			
+24V	8			
AUX 232 RXC Port C	9	I		RS232 Input
24MCR	10			24 Volts when not in E-Stop
24MCR	11			24 Volts when not in E-Stop
Estop relay	12	relay		Used to seal E-Stop
Aux Input #3	13	I	X1.1	
Tamp / Aux Output #2 / Powered Label Platen	14	O	Y1.7	High current
+24V	15			

SECTION 5

CLEANING & MAINTENANCE

Troubleshooting	50
Fault Codes	51
Replacing the Main Power Fuse	52

TROUBLESHOOTING GUIDE

If the system malfunctions, it is necessary to determine where the problem exists in a normal sequence of operation. Possible error conditions are listed in the left-hand column to provide a systematic approach to troubleshooting.

Error Condition	Possible Cause	Corrective Action
Unit will not turn on	Blown main fuse	Check main power fuse and replace if necessary
Air system will not operate	No air pressure Plugged hose Faulty valve	Check air supply and filter Fix or replace hose Consult factory
Take-up unit does not turn	Friction plate failure in clutch Mechanical failure in clutch	Consult Factory
Waste web tension too loose	Clutch tension too low	Adjust clutch as shown on page 16
Waste web breaks	Clutch adjusted too tight Machine webbed wrong Low quality webbing Friction plate failure in clutch Mechanical failure in clutch	Adjust clutch as shown on page 16 Re-web system as shown in section 2 Consult label manufacturer Consult factory. Consult factory.
Label double feeds	Web sensor out of adjustment	Adjust setting as shown on page 12
Tamp cylinder not up	No air Hoses not connected correctly	Connect air and/or adjust regulator
Applicator module does not function	Incorrect Cycle Type No air Hoses not connected correctly	Set correct Cycle Type in control Connect air and/or adjust regulator
Power ON tamp/flag system unit will not cycle	Cylinder not up Reed Switch out of adjustment Incorrect Cycle Type	Refer to #7 Adjust Switch up or down Set correct Cycle Type in control

FAULT CODES

DISPLAYED FAULT	DESCRIPTION	CORRECTIVE ACTION
Memory Checksum	Data lost in serial EEPROM	Consult factory or service provider
Gap Not Detected (10 second time out)	Too many labels missing on web Labeler not webbed properly Web sensor not adjusted properly	Check label stock Check for proper webbing Adjust setting as shown on page 12
Label Not Found	Label not sensed in auto set up	Check label stock Check label sensor Adjust setting as shown on page 12
Head Up Fault	Head up limit switch on tamp did not trigger	Check for proper adjustment of head up limit switch Check air to system Check programming of Tamp switch
Head Down Fault	Head up limit switch failed to switch during the tamp cycle	Tamp duration too small Faulty limit switch Check air to system Check programming of Tamp switch
Print Timeout Fault	End of Print Signal was not received with "Printer" setting enabled	Turn off Printer setting (if external printer is not being used). Check Printer Settings. Inspect / Replace Interface Cable.

REPLACING THE MAIN POWER FUSE

The circuitry is protected from a current overload by GMA 2A a slow blow fuse. Should the applicator fail to operate, the condition of this fuse should be checked. If the fuse is open, the cause of the overload condition must be determined and corrected prior to replacing the fuse. NEVER replace the fuse with one of a greater amp rating. The specified rating has been selected to prevent damage and/or injury.

ACTIONS TO REPLACE THE MAIN FUSE

1. Set the main power switch to the OFF position.
2. Disconnect the AC power cable from the rear of the console.
3. Locate the fuse holder/power cord assembly.
4. Gently press down the fuse holder cover while pulling away from the console.
5. Replace with the spare fuse provided in the holder.



LM4012

AUTOMATIC LABEL APPLICATOR

OPERATIONS MANUAL



Copyright and Trademarks

Copyright ©2021 LabelMill
All rights reserved. All trademarks and brand names
are the property of their respective owners.

LabelMill
2416 Jackson St.
Savanna, IL 61074

Phone: (800) 273-4707; Fax (815) 273-7074
www.labelmill.com
info@labelmill.com